

Kennerly

HEATHKIT® MANUAL

ASSEMBLY

Model SB-230

LINEAR AMPLIFIER

I-595-1596-02

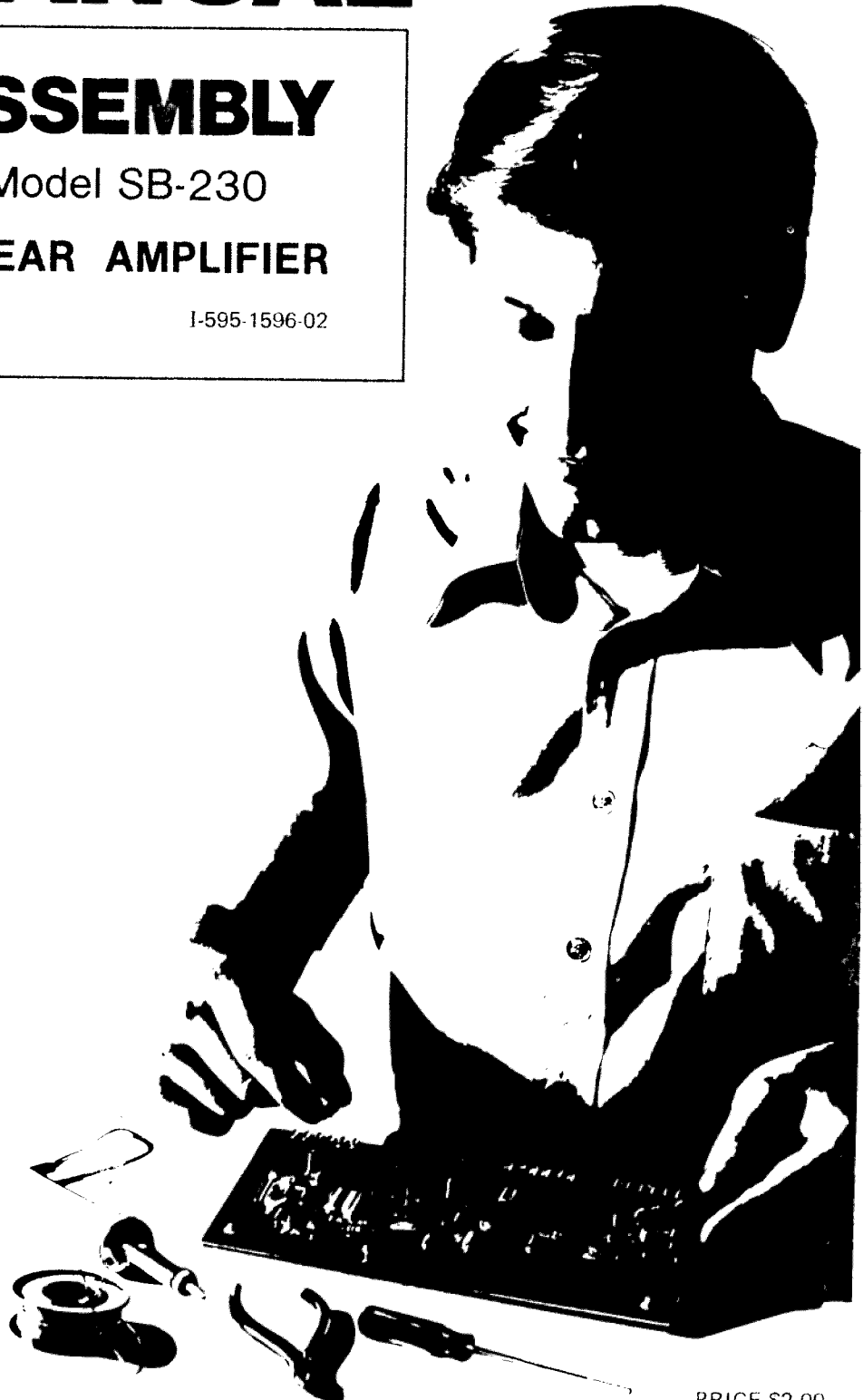

HEATH COMPANY PHONE DIRECTORY

The following telephone numbers are direct lines to the departments listed:

Kit orders and delivery information	(616) 982-3411
Credit	(616) 982-3561
Replacement Parts	(616) 982-3571
<i>Technical Assistance:</i>	
R/C, Audio, and Electronic Organs	(616) 982-3310
Amateur Radio	(616) 982-3296
Test Equipment, Strobe Lights, Calculators, Clocks, Weather Instruments	(616) 982-3315
Television	(616) 982-3307
Automotive, Marine, Appliances, Security, General Products	(616) 982-3496

YOUR HEATHKIT 90-DAY FULL WARRANTY

During your first ninety (90) days of ownership, Heath Company will replace or repair free of charge — as soon as practical — any parts which are defective, either in materials or workmanship. You can obtain parts directly from Heath Company by writing us or telephoning us at (616) 982-3571. And we'll pay shipping charges to get those parts to you — anywhere in the world.

We warrant that, during the first ninety (90) days of ownership, our products, when correctly assembled, calibrated, adjusted, and used in accordance with our printed instructions, will meet published specifications.

If a defective part or error in design has caused your Heathkit product to malfunction during the warranty period, through no fault of yours, we will service it free upon delivery at your expense to the Heath factory, Benton Harbor, Michigan, or to any Heathkit Electronic Center (units of Schlumberger Products Corporation), or through any of our authorized overseas distributors.

You will receive free consultation on any problem you might encounter in the assembly or use of your Heathkit product. Just drop us a line or give us a call. Sorry, we cannot accept collect calls.

Our warranty, both expressed and implied, does not cover damage caused by use of corrosive solder, defective tools, incorrect assembly, misuse, fire, customer-made modifications, flood or acts of God, nor does it include reimbursement for customer assembly or setup time. The warranty covers only Heath products and is not extended to non-Heath allied equipment or components used in conjunction with our products or uses of our products for purposes other than as advertised.

And if you are dissatisfied with our service — warranty or otherwise — or our products, write directly to our Director of Customer Services, Heath Company, Benton Harbor, Michigan, 49022. He'll make certain your problems receive immediate personal attention.

HEATH COMPANY
BENTON HARBOR, MI. 49022

Prices and specifications subject to change without notice.

Assembly
and
Operation
of the



LINEAR AMPLIFIER

MODEL SB-230

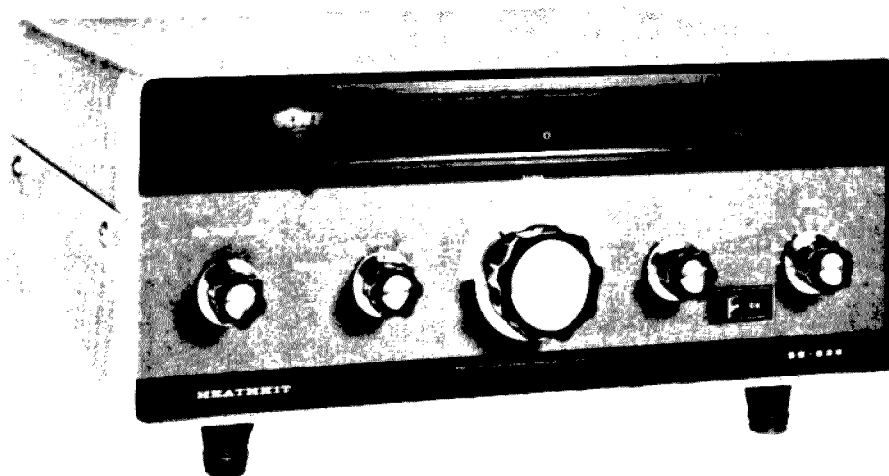

HEATH COMPANY
BENTON HARBOR, MICHIGAN 49022

TABLE OF CONTENTS

INTRODUCTION	3
ASSEMBLY NOTES	5
CIRCUIT BOARDS	
Parts List	7
Step-by-Step Assembly	9
CHASSIS	
Parts List	13
STEP-BY-STEP ASSEMBLY	29
RF Chassis	30
RF Enclosure	46
Power Supply Chassis	48
Assembled Chassis	58
TESTS AND FINAL ASSEMBLY	87
INSTALLATION	89
OPERATION	
Control Functions	93
Reading the Meter	95
Driving Power	96
Tune-Up	97
IN CASE OF DIFFICULTY	101
Troubleshooting	103
SPECIFICATION	105
CIRCUIT DESCRIPTION	107
CHASSIS PHOTOGRAPHS	109
CIRCUIT BOARD X-RAY VIEWS	113
SCHMATIC . . . (fold-out from page)	113
WARRANTY	Inside front cover
CUSTOMER SERVICE	Inside rear cover

INTRODUCTION

The Heathkit Model SB-230 Linear Amplifier is a completely self-contained, grounded-grid, table top amplifier for use on the 80, 40, 20, 15 and 10 meter amateur bands. Because it uses a type 8873 tube, which is conduction cooled by a large heat sink, fan noise is eliminated and it is completely quiet in operation. The Amplifier is rated at a power input of 1200 watts peak envelope power for voice operation on SSB, at 1000 watts for CW, or at 400 watts for RTTY or SSTV.

The power transformer has a dual primary winding and can be operated from either 120 or 240 VAC, 50/60 Hertz electric supply lines. Operation from a 240 volt line is recommended, but not required. The Amplifier is designed for use with exciters which deliver 100 watts output. It can be used with lower driving power, but its output will be less.

If it is overdriven, the Amplifier develops ALC voltage to reduce the gain of the exciter. An "exciter only" switch is

provided so the Amplifier, after warm-up, can be instantaneously switched into or out of use.

Protective devices are: a circuit breaker in the power transformer primary, a time delay to insure adequate warm-up time for the tube, a thermal circuit breaker to cut off the tube should the Amplifier be overheated, and a fuse to protect against excessive plate drive. Convenient visual indicators are included on the panel to show when the Amplifier is ready to operate after turn-on, to show when the Amplifier is switched to "exciter only," and to indicate when the thermal circuit breaker has operated.

Read the "Kit Builders Guide" for complete information on unpacking, parts identification, tools, wiring, soldering, and step-by-step assembly procedures.

VERY IMPORTANT:

BERYLLIUM OXIDE (BeO) CERAMIC BLOCK

The ceramic block fitted between the power tube and heat sink is made of high-fired beryllium oxide (BeO). We chose this particular material because of its superior thermal conductivity and high electrical resistivity -- it is by far the best substance we know of to efficiently transmit the intense heat of the power tube to the heat sink where it is dissipated into the air. While the normal installation and use of this ceramic block is totally safe and will not expose you to any danger, nevertheless, we should caution you that beryllium oxide in its vapor and dust forms is a deadly poison and should never be swallowed, breathed, or brought into contact with the skin or ~~eyes~~ eyes. Under no circumstances should the beryllium oxide ceramic block be drilled, chipped, crushed, sawed, sanded, ground, filed, or subjected to any other dust producing operation. Nor should the block be brought into contact with any acid or other chemical solution except as described below. The block should never be heated to over 1,000°C (the unit has been designed so

that the block will not be subjected to temperatures in excess of 400°C).

Should the block become cracked, chipped, or even pulverized or should dust be produced in any other way, remove the small pieces (and dust) with a wet paper towel. Then discard the towel in a sealed plastic bag. Beryllium oxide dust or particles should never be swept or vacuumed. Should you desire for any reason to remove the filler material used to connect the power tube to the block and the block to the heat sink, do so with a rag dipped in a solvent such as lacquer thinner or Varsol. Then discard the rag in a sealed plastic bag. Never attempt to scrape the filler material from the beryllium oxide block.

Wash your hands thoroughly after any contact with the beryllium oxide block.

ASSEMBLY NOTES

Each circuit part in this kit has its own component number (R2, C4, etc.). Use these numbers when you want to positively identify the same part in the various sections of the Manual. These numbers, which are especially useful if a part has to be replaced, appear:

- In the Parts Lists,
- At the beginning of each step where a component is installed,
- In some illustrations,
- In the Schematic,
- In the sections at the rear of the Manual.



CIRCUIT BOARDS

PARTS LIST

The parts for your Amplifier are in two packs. Remove the pack marked "PK 1" (pack 1) from the box; remaining parts are pack 2.

Some parts are packaged in envelopes with the part number of the contents printed on the outside. Except for the initial parts check, keep these parts in their envelopes so they can be easily identified when they are called for in the assembly steps.

Check the parts from pack 1 against the following list. You will also need several parts from pack 2, as listed. The illustrations will show you what the parts look like. Only the hardware is drawn to actual size.

To order a replacement part, always include the PART NUMBER. Use the Parts Order Form furnished with this kit. If one is not available, see "Replacement Parts" inside the rear cover of this Manual. Your Warranty is located inside the front cover. For pricing information, refer to the separate "Heath Parts Price List."

PACK #1

QTY.	DESCRIPTION	PART No.	CIRCUIT Component No.
------	-------------	----------	-----------------------

RESISTORS

NOTE: The following resistors are 1/2-watt unless otherwise noted.

(X)	3	10 k Ω (brown-black-orange)	1-20	R24, 28, 32
(X)	4	22 k Ω (red-red-orange)	1-22	R26, 27, 29, 31
(X)	1	100 k Ω , 2-watt (brown-black-yellow)	1-24-2	R22

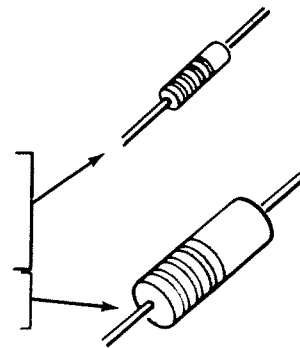

QTY.	DESCRIPTION	PART No.	CIRCUIT Component No.
------	-------------	----------	-----------------------

OTHER

X	15	1N2071 diode	57-27	D1-16
--------------	----	--------------	-------	-------

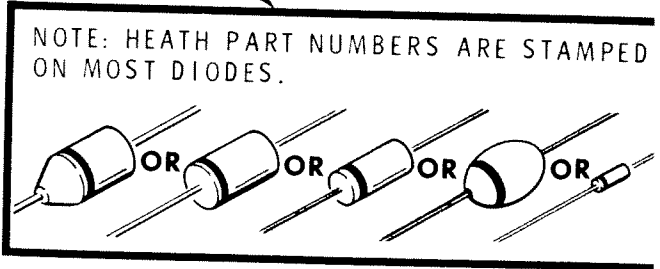

X	2	MPSA42 transistor	417-294	Q1, 2
X	10	Connector pin	432-121	
X	3	H2-A neon lamp	412-99	PL2, 3, 4
X	1	40 μ F capacitor	25-20	C16

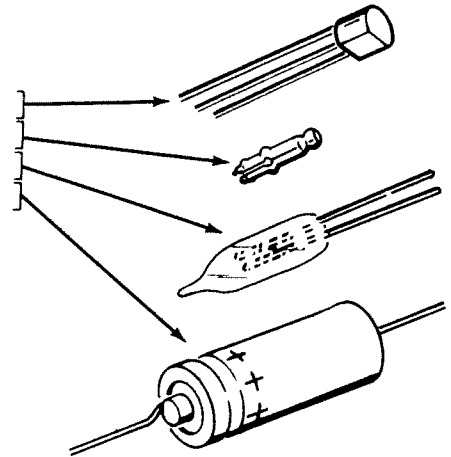

PARTS FROM PACK #2

(1	Small black sleeving	346-1	
X	1	Power supply circuit board	85-1440-1	
X	1	Lamp indicator circuit board	85-1589-1	

Solder

STEP-BY-STEP ASSEMBLY

START



Position the lamp indicator circuit board (#85-1589-1) with the lettered side up as shown. Then perform the steps on this page.

FOR GOOD SOLDER CONNECTIONS, YOU MUST KEEP THE SOLDERING IRON TIP CLEAN. WIPE IT OFTEN WITH A DAMP SPONGE OR CLOTH



R29: 22 kΩ (red-red-orange).

R28: 10 kΩ (brown-black-orange).

NOTE: When you install a transistor, line up the flat on the transistor with the outline of the flat on the circuit board. Then insert the leads into their correct E, B, and C holes. Solder the leads to the foil and cut off the excess lead lengths.

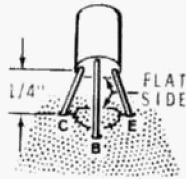

Q1: MPSA42 (#417-294).

R27: 22 kΩ (red-red-orange).

R26: 22 kΩ (red-red-orange).

SAFETY WARNING: Avoid eye injury when you clip off excess leads. We suggest that you wear glasses, or at least clip the leads so the ends will not fly toward your eyes.

Solder the resistor leads to the foil and cut off the excess lead lengths.

CONTINUE



NOTE: Install connector (#432-121) in the following location. Solder each pin to the foil as it is installed.

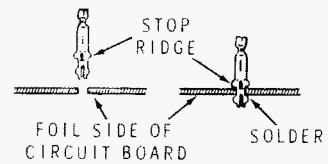

Connector pin at 3.

Connector pin at 2.

R24: 10 kΩ (brown-black-orange).

R32: 10 kΩ (brown-black-orange).

Q2: MPSA42 (#417-294). The position of the flat is opposite that of Q1.

R31: 22 kΩ (red-red-orange).

Solder the leads to the foil and cut off the excess lead lengths.

Connector pin at 1. Solder the pin to the foil.

Connector pin at 4. Solder the pin to the foil.

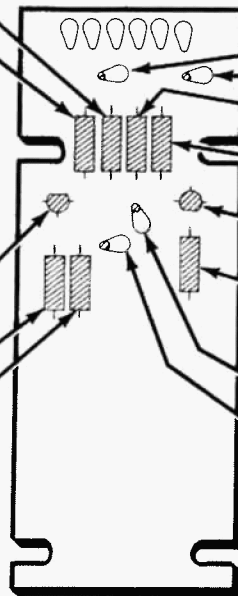

PICTORIAL 1

START

- Cut six lengths of black sleeving 3/4" long.
 - Slide 3/4" lengths of black sleeving onto the six leads of three neon lamps.
 - Push the leads of a neon lamp into holes E and F until the sleeving touches the circuit board. Solder the leads to the foil and cut off the excess lead lengths.
- SMALL NEON LAMP
3/4" SLEEVING
- In a similar manner, install the second neon lamp in holes C and D.
 - In a similar manner, install the third neon lamp in holes A and B.

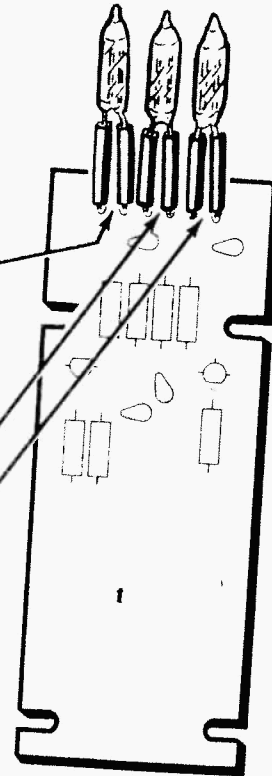

- ### CIRCUIT BOARD CHECKOUT
- Carefully inspect the circuit board for the following conditions.
- Unsoldered connections.
 - "Cold" solder connections.
 - Solder bridges between foil patterns.
 - Protruding leads. No leads or lugs should be longer than 1/8".
 - Transistors for the proper type and installation.

PICTORIAL 2

- Lay the circuit board aside. It will be installed later.

FINISH

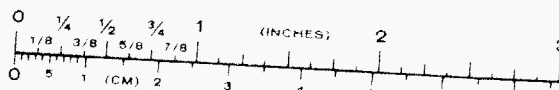

START ↓

CONTINUE ↓

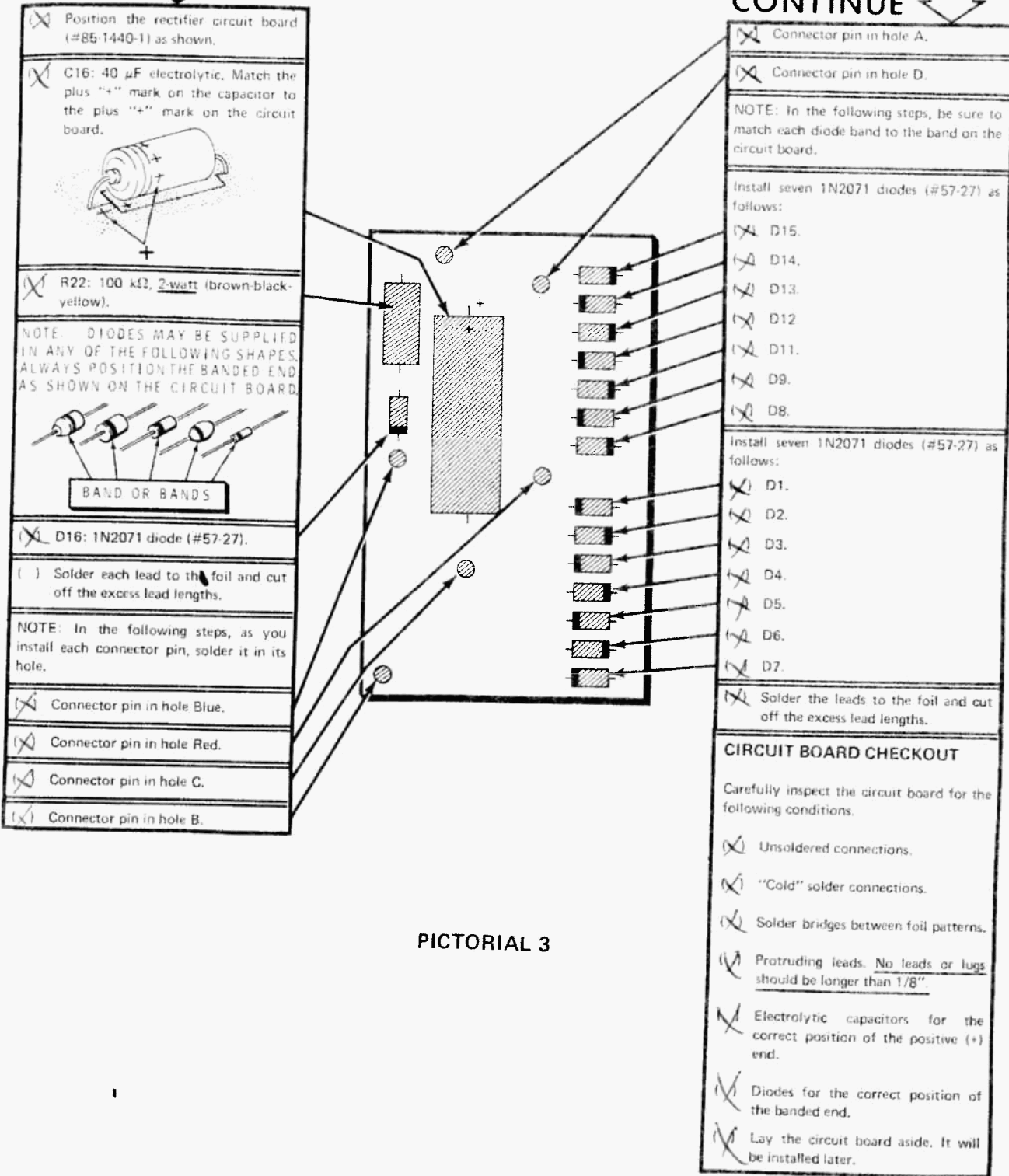

- Position the rectifier circuit board (#85-1440-1) as shown.
- C16: 40 μ F electrolytic. Match the plus "+" mark on the capacitor to the plus "+" mark on the circuit board.
- R22: 100 k Ω , 2-watt (brown-black-yellow).
- NOTE: DIODES MAY BE SUPPLIED IN ANY OF THE FOLLOWING SHAPES. ALWAYS POSITION THE BANDED END AS SHOWN ON THE CIRCUIT BOARD.

BAND OR BANDS
- D16: 1N2071 diode (#57-27).
- () Solder each lead to the foil and cut off the excess lead lengths.
- NOTE: In the following steps, as you install each connector pin, solder it in its hole.
- Connector pin in hole Blue.
- Connector pin in hole Red.
- Connector pin in hole C.
- Connector pin in hole B.

- Connector pin in hole A.
- Connector pin in hole D.
- NOTE: In the following steps, be sure to match each diode band to the band on the circuit board.
- Install seven 1N2071 diodes (#57-27) as follows:
 - D15.
 - D14.
 - D13.
 - D12.
 - D11.
 - D9.
 - D8.
- Install seven 1N2071 diodes (#57-27) as follows:
 - D1.
 - D2.
 - D3.
 - D4.
 - D5.
 - D6.
 - D7.

- Solder the leads to the foil and cut off the excess lead lengths.

- CIRCUIT BOARD CHECKOUT**
- Carefully inspect the circuit board for the following conditions.
- Unsoldered connections.
 - "Cold" solder connections.
 - Solder bridges between foil patterns.
 - Protruding leads. No leads or lugs should be longer than 1/8".
 - Electrolytic capacitors for the correct position of the positive (+) end.
 - Diodes for the correct position of the banded end.
 - Lay the circuit board aside. It will be installed later.

PICTORIAL 3

FINISH



CHASSIS

PARTS LIST

Unpack the remaining parts and check each part against the following list.

be easily identified when they are called for in the assembly steps.

Some parts are packaged in envelopes with the part number of the contents printed on the outside. Except for the initial parts check, keep these parts in their envelopes so they can

To order a replacement part; use the Parts Order Form furnished with this kit. If one is not available, refer to "Replacement Parts" inside the rear cover of the Manual.

<u>QTY.</u>	<u>DESCRIPTION</u>	<u>PART No.</u>	<u>CIRCUIT Component No.</u>
-------------	--------------------	-----------------	------------------------------

RESISTORS

NOTE: The following resistors are 1/2-watt, 10% tolerance, unless otherwise noted. 10% is indicated by a fourth color band of silver; 5% tolerance is indicated by a fourth color band of gold.

()	1	1.5 Ω (brown-green-gold)	1-140	R25
()	1	47 Ω (yellow-violet-black)	1-1	R33
()	1	680 Ω (blue-gray-brown-gold)	1-52	R11
()	1	1000 Ω (brown-black-red)	1-9	R35
()	2	22 k Ω (red-red-orange)	1-22	R18, 19
()	1	100 k Ω (brown-black-yellow)	1-26	R15

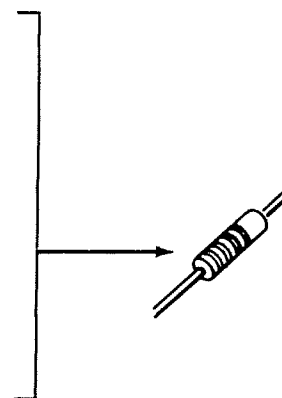

QTY.	DESCRIPTION	PART No.	CIRCUIT Component No.
Other			
() 1	33 Ω , 1-watt (orange-orange-black)	1-14-1	R17
() 1	470 Ω , 1-watt (yellow-violet-brown)	1-1-1	R16
() 1	27 k Ω , 1-watt (red-violet-orange)	1-46-1	R36
() 15	1500 Ω , 2-watt (brown-green-red)	1-14-2	R21
() 6	100 k Ω , 2-watt (brown-black-yellow)	1-24-2	R3, 4, 5, 6, 7, 8
() 3	1 M Ω , 2-watt (brown-black-green-gold)	1-31-2	R12, 13, 14
() 1	1 Ω , 1%, 5-watt	3-25-5	R9
() 2	500 Ω , 5-watt	3-31-5	R1, 2
() 1	1500 Ω , 10-watt	3-11-10	R23
() 1	100 k Ω control	10-12	R34

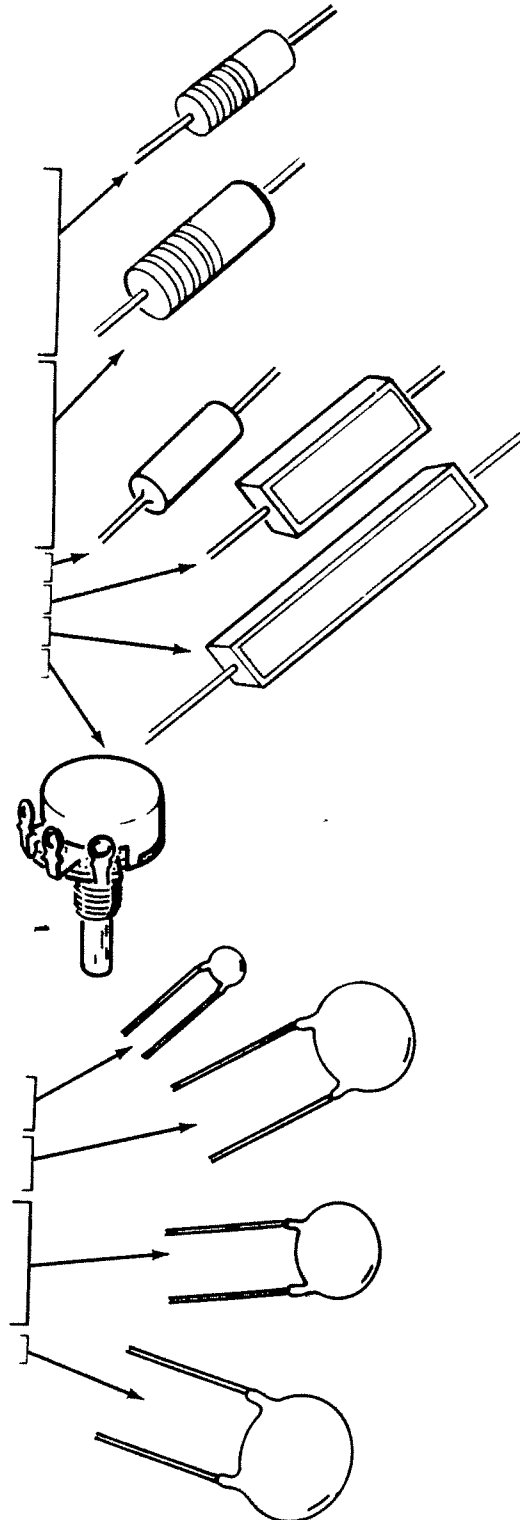

CAPACITORS

Disc			
() 1	18 pF	21-60	C24
() 2	.001 μ F, 500 volt	21-140	C18, 26
() 1	.001 μ F, 6000 volt, 20%	21-79	C9
() 5	.01 μ F	21-16	C17, 19, 25, 28, 29
() 2	.01 μ F, 1400 volt	21-70	C1, 2
() 3	.02 μ F	21-31	C21, 27, 33
() 1	.02 μ F, 1600 volt	21-38	C32

QTY.	DESCRIPTION	PART No.	CIRCUIT Component No.
Other			
() 1	12 pF mica	20-130	C22
() 1	100 pF (100 MMF), 5000 volt	21-109	C13
() 1	.001 μ F, 6000 volt (1000 MMF)	21-165	C11
() 1	500 pF mica, 2000 volt	20-123	C14
() 2	.001 μ F feedthrough	21-53	C23, 31
() 6	125 μ F electrolytic	25-34	C3, 4, 5, 6, 7, 8

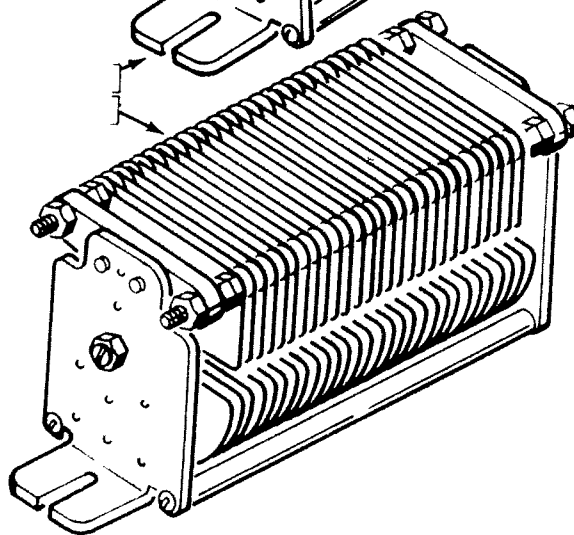
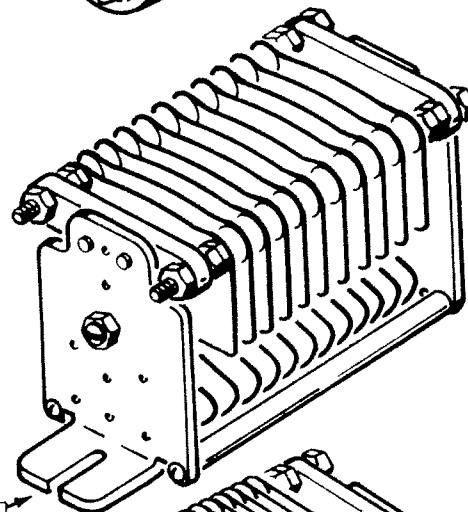
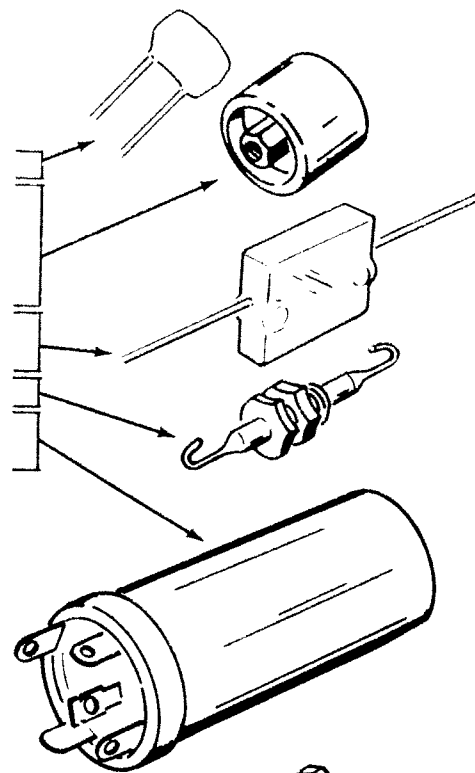

() 1	140 pF variable	26-144	C12
() 1	840 pF variable	26-145	C15

QTY.	DESCRIPTION	PART No.	CIRCUIT Component No.
------	-------------	----------	-----------------------

INDUCTORS

()	1	10-15 meters	40-1665	L1
()	1	80-40-20 meters	40-1666	L2

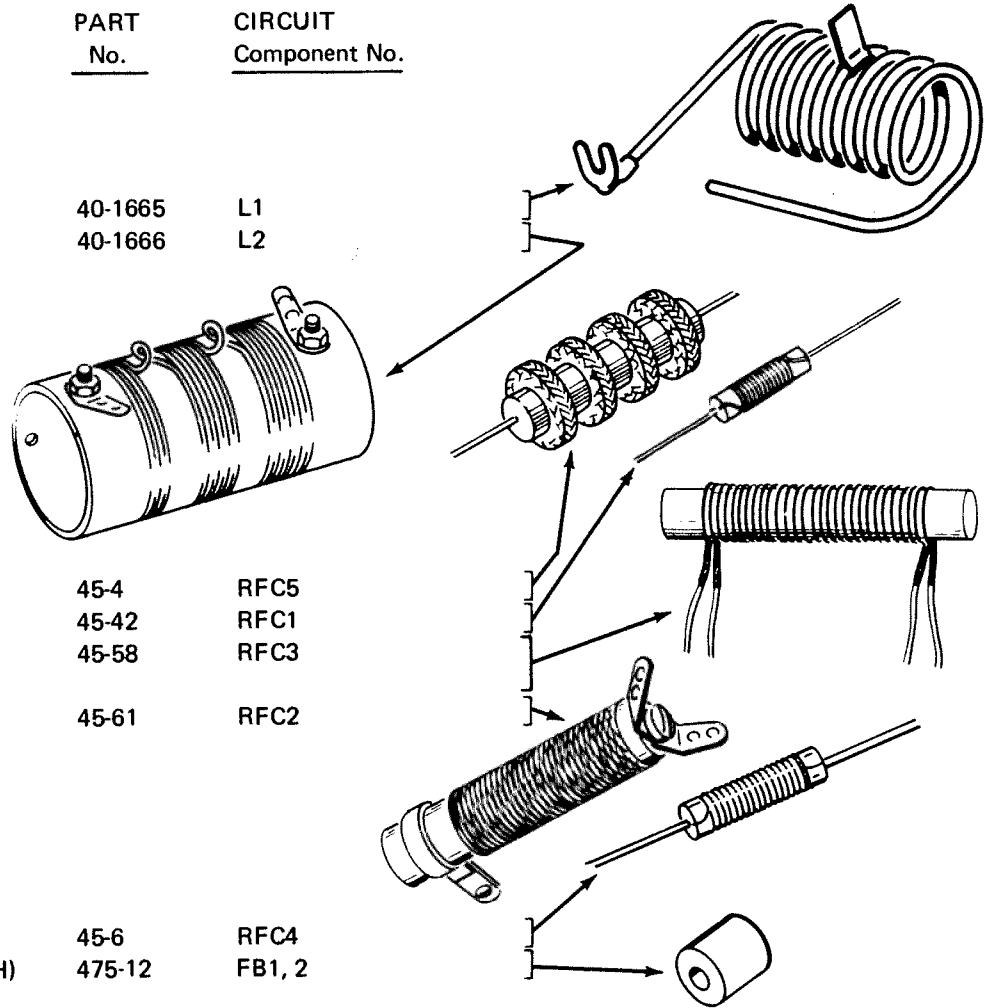

()	1	1.1 mH RF choke	45-4	RFC5
()	1	8.75 μ H RF choke	45-42	RFC1
()	1	13.5 μ H Bifilar RF choke	45-58	RFC3
()	1	50 μ H RF choke	45-61	RFC2
()	1	8.5 μ H RF Choke	45-6	RFC4
()	2	Ferrite bead (1.7 μ H)	475-12	FB1, 2

NOTE: HEATH PART NUMBERS ARE STAMPED ON MOST DIODES.

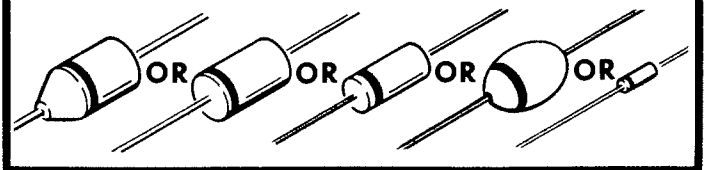

DIODES

()	1	1N458 diode	56-24	D19
()	1	1N191 diode	56-26	D18
()	1	1N2071 diode	57-27	D17
()	1	1N2806A Zener diode (8.2 volt)	56-609	ZD1

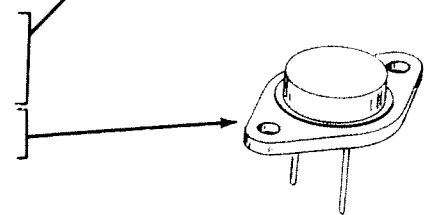

QTY.	DESCRIPTION	PART No.	CIRCUIT Component No.
------	-------------	----------	-----------------------

WIRE AND SLEEVING

Wire

()	1	Bare	340-1
()	1	RG-58A/U	343-2
()	1	Blue	344-13
()	1	Large brown (stranded)	344-31
()	1	Black	344-50
()	1	Small brown (tinned)	344-34
()	1	Red	344-52
()	1	Yellow	344-54
()	1	Violet	344-57
()	1	White	344-59
()	1	White-black	344-70
()	1	White-brown	344-71
()	1	White-red	344-72
()	1	White-yellow	344-74
()	1	White-blue	344-76
()	1	Wire braid	345-1
()	1	Line cord	89-50

Sleeving

()	1	Small clear sleeving	346-2
()	1	Large black sleeving	346-20
()	1	Large clear sleeving	346-26

SWITCHES AND RELAYS

X	1	2-wafer switch	63-700	SW3
X	1	1-wafer switch (appearance may differ)	63-701	SW2
X	1	Thermal circuit breaker	65-59	TC
X	1	Rocker switch w/breaker	65-53	SW1
X	1	Relay	69-55	RY1
X	1	Time delay relay	69-74	RY2
X	2	Interlock switch	64-24	SW4, SW5

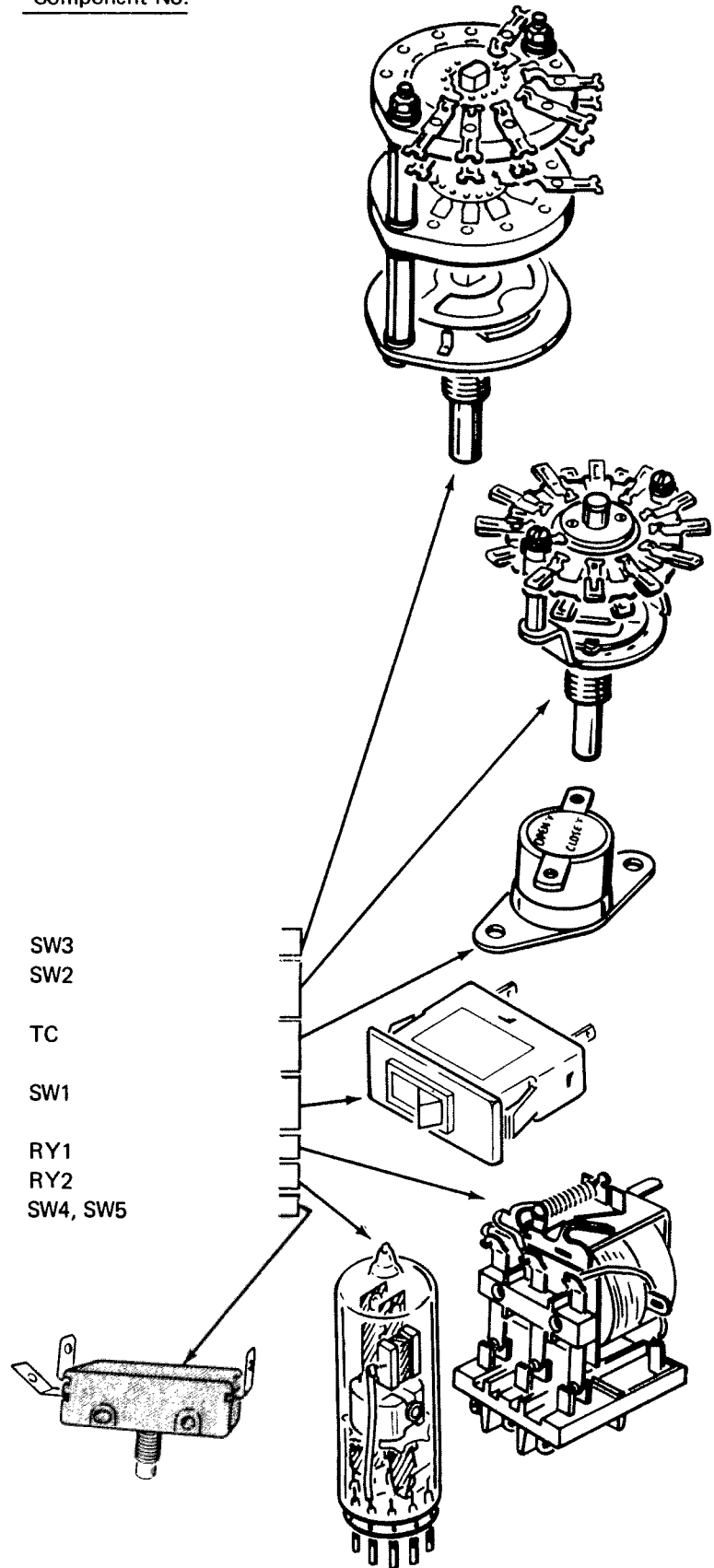

QTY.	DESCRIPTION	PART No.	CIRCUIT Component No.
------	-------------	----------	-----------------------

INSULATORS

()	1	Foam strip	73-39
()	2	Rubber grommet	73-2
()	4	Large plastic grommet	73-45
()	2	Small plastic grommet	73-52
()	1	Strain relief	75-29
()	8	Nylon insulator	75-53
()	1	Fish paper	75-68
()	1	White insulator	75-701
()	1	Beryllium oxide block — (see WARNING on page 4).	75-702
()	12	Capacitor mounting wafer	481-3

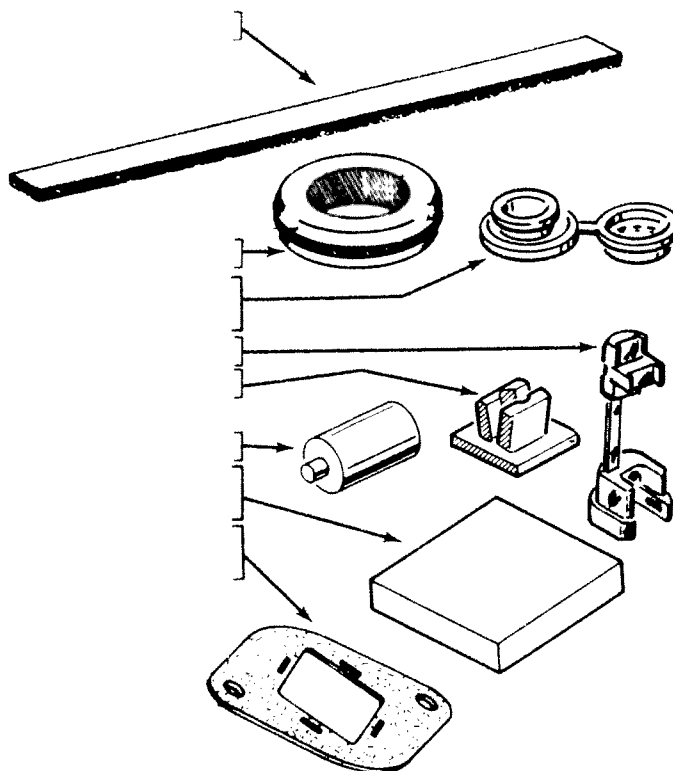

HARDWARE

NOTE: Hardware is illustrated actual size.

#2 Hardware

()	2	2-56 x 3/8" screw	250-175
()	2	2-56 nut	252-51
()	2	#2 lockwasher	254-26

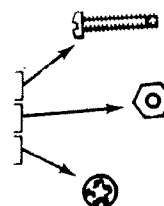

#3 Hardware

()	1	3-48 x 7/16" brass screw	250-133
()	4	#3 flat washer	253-94

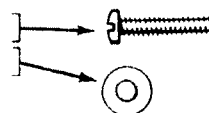

QTY.	DESCRIPTION	PART No.	CIRCUIT Component No.
#4 Hardware			
() 2	4-40 x 1/4" screw	250-52	
() 6	4-40 x 5/16" screw	250-213	
() 11	4-40 x 1/2" square head screw	250-1194	
() 4	4-40 x 1" square head screw	250-1188	
() 21	4-40 nut	252-2	
() 30	#4 lockwasher	254-9	

#6 Hardware			
() 1	6-32 x 3/16" screw	250-138	
() 22	6-32 x 1/4" screw	250-56	
() 42	6-32 x 3/8" screw	250-89	
() 2	6-32 x 3/8" flat head screw	250-434	
() 4	6-32 x 1/2" screw	250-162	
() 19	#6 x 1/2" sheet metal screw	250-1195	
() 6	6-32 x 3/4" screw	250-29	
() 4	6-32 x 1" screw	250-13	
() 2	6-32 x 1-1/2" screw	250-40	
() 1	6-32 x 2" screw	250-27	
() 2	6-32 spade lug	251-7	
() 53	6-32 nut	252-3	
() 2	6-32 Speed Nut*	252-22	
() 2	#6 fiber washer	253-1	
() 2	#6 flat washer	253-60	
() 64	#6 lockwasher	254-1	
() 15	#6 solder lug	259-1	

#8 Hardware			
() 6	8-32 x 1/4" setscrew	250-43	
() 2	8-32 x 3" screw	250-393	
() 3	#8 solder lug	259-24	

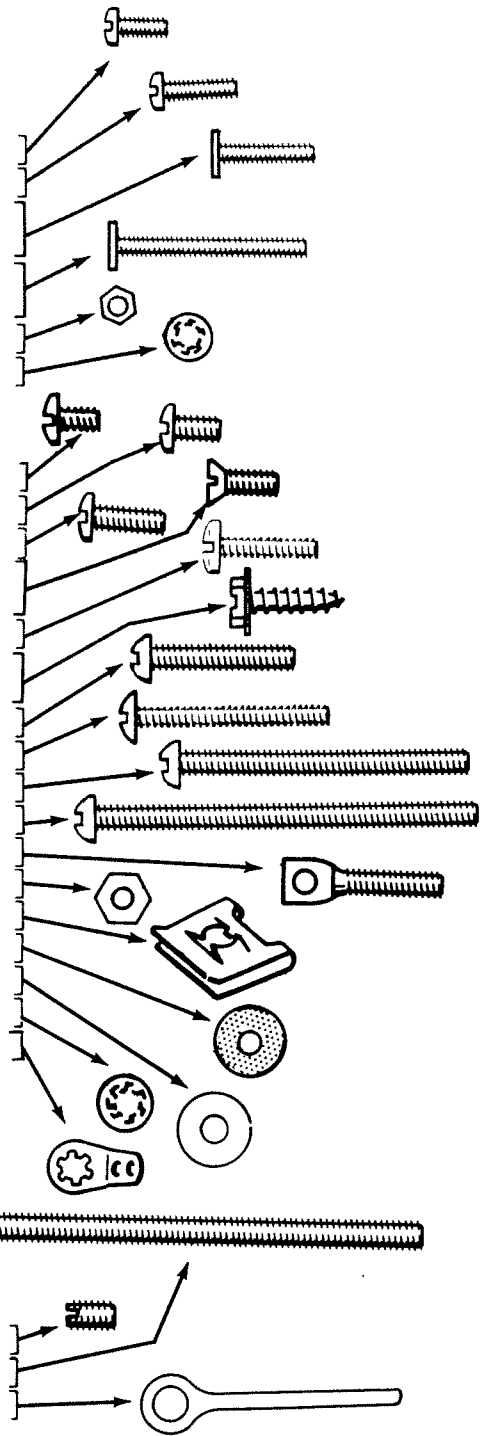

*Tinnerman Registered Trademark

QTY.	DESCRIPTION	PART No.	CIRCUIT Component No.
------	-------------	----------	-----------------------

#10 Hardware

()	8	10-32 x 1/2" screw	250-456
()	1	10-24 x 3/4" screw	250-152
()	6	10-32 nut	252-5
()	1	10-24 nut	252-30
()	1	10-24 wing nut	252-31
()	14	3/4" O.D. flat washer	253-19
()	2	#10 solder lug	259-5
()	5	#10 lockwasher	254-3

Other Hardware

()	6	Control flat washer	253-10
()	1	Control solder lug	259-10
()	6	Control nut	252-7
()	2	Control lockwasher	254-4
()	2	Spade solder lug	259-22
()	3	Shaft bushing	455-9

SPACERS

()	1	4-40 x 5/8" tapped spacer	255-164
()	2	15/32" spacer, tapped 6-32	255-23
()	2	1-1/4" phenolic spacer, tapped 6-32	255-39
()	2	3/16" shoulder spacer, tapped 6-32	255-79
()	2	17/32" plastic spacer, tapped 6-32	255-152
()	4	3/16" spacer	255-2
()	1	1-1/2" spacer	255-10

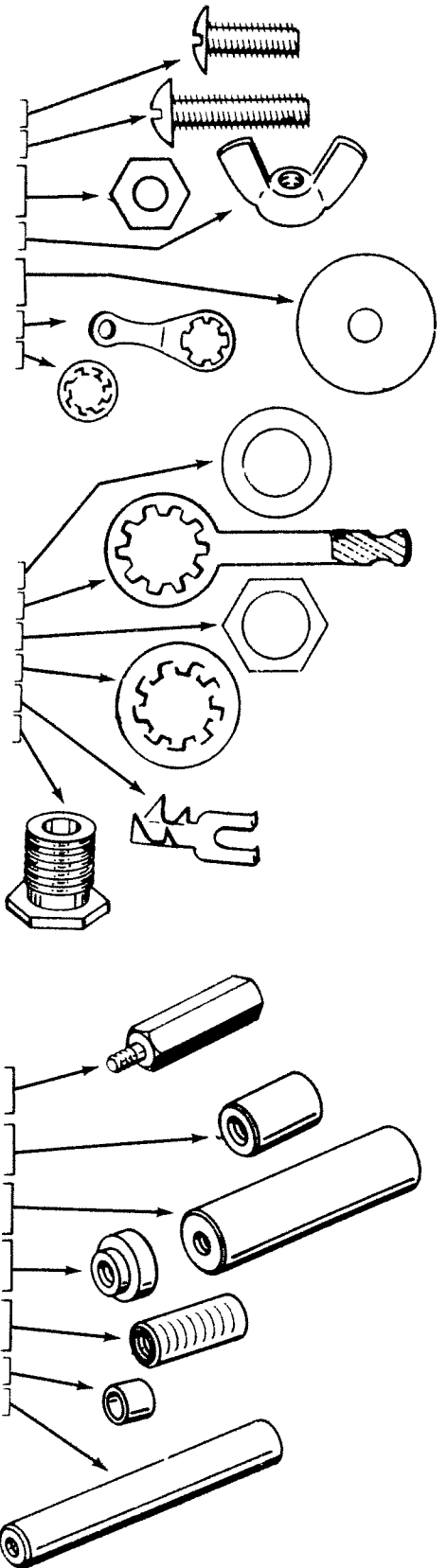

QTY.	DESCRIPTION	PART No.	CIRCUIT Component No.
------	-------------	-------------	--------------------------

METAL PARTS

(1) 1 Top cabinet shell 90-1106-4

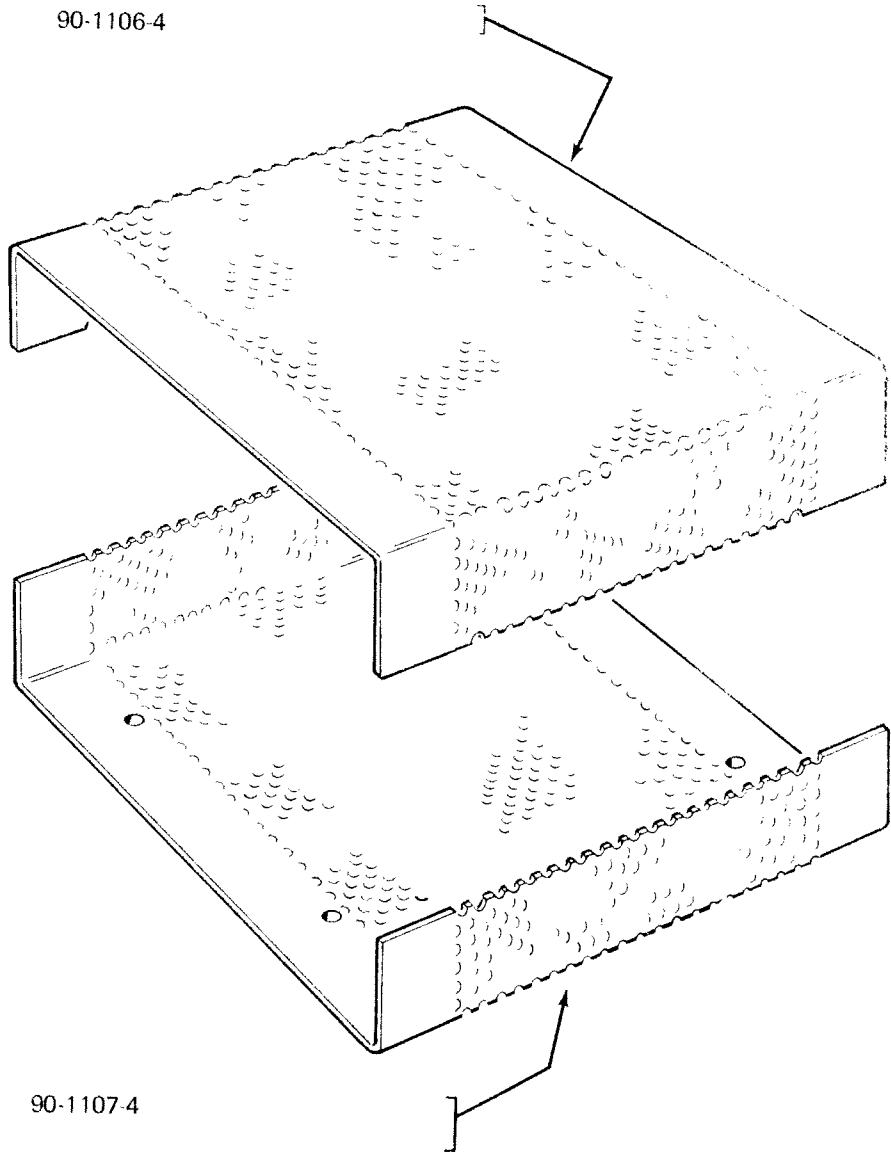

2. 1 Bottom cabinet shell 90-1107-4

<u>QTY.</u>	<u>DESCRIPTION</u>	<u>PART No.</u>	<u>CIRCUIT Component No.</u>
-------------	--------------------	-----------------	------------------------------

Metal Parts (cont'd.)

1	RF chassis	100-1633	
--------------	------------	----------	--

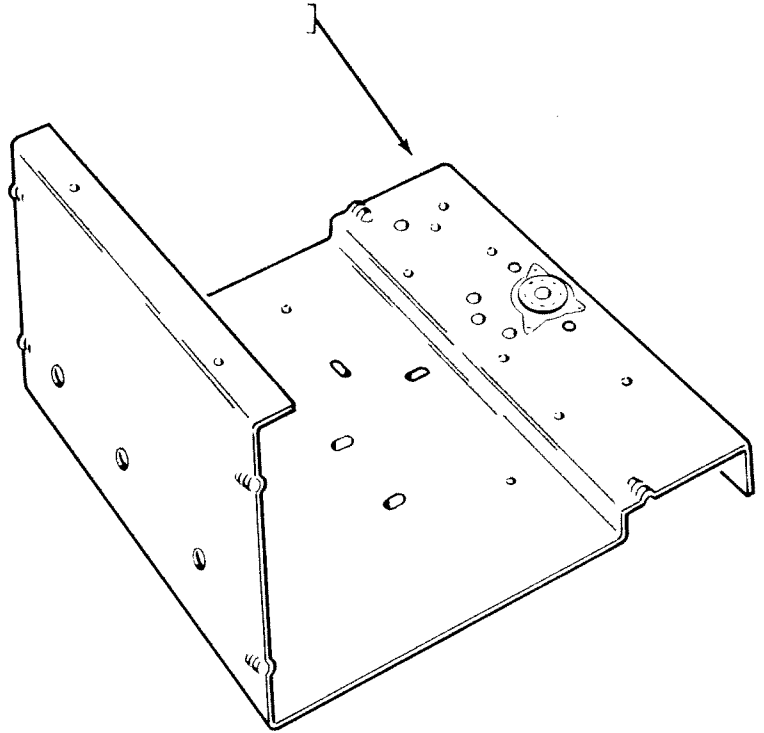

1	Power supply chassis	200-676	
--------------	----------------------	---------	--

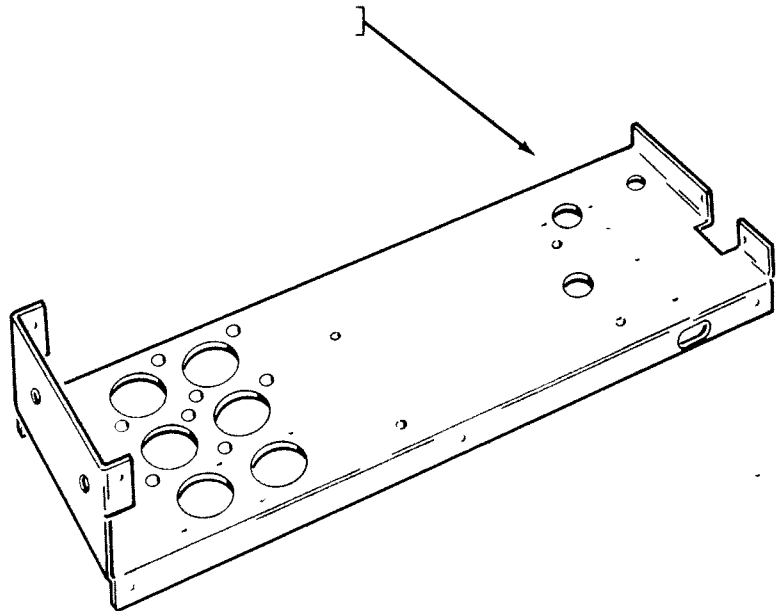

QTY.	DESCRIPTION	PART No.	CIRCUIT Component No.
------	-------------	----------	-----------------------

Metal Parts (cont'd.)

<i>Z</i> 1	RF enclosure	200-677	
------------	--------------	---------	--

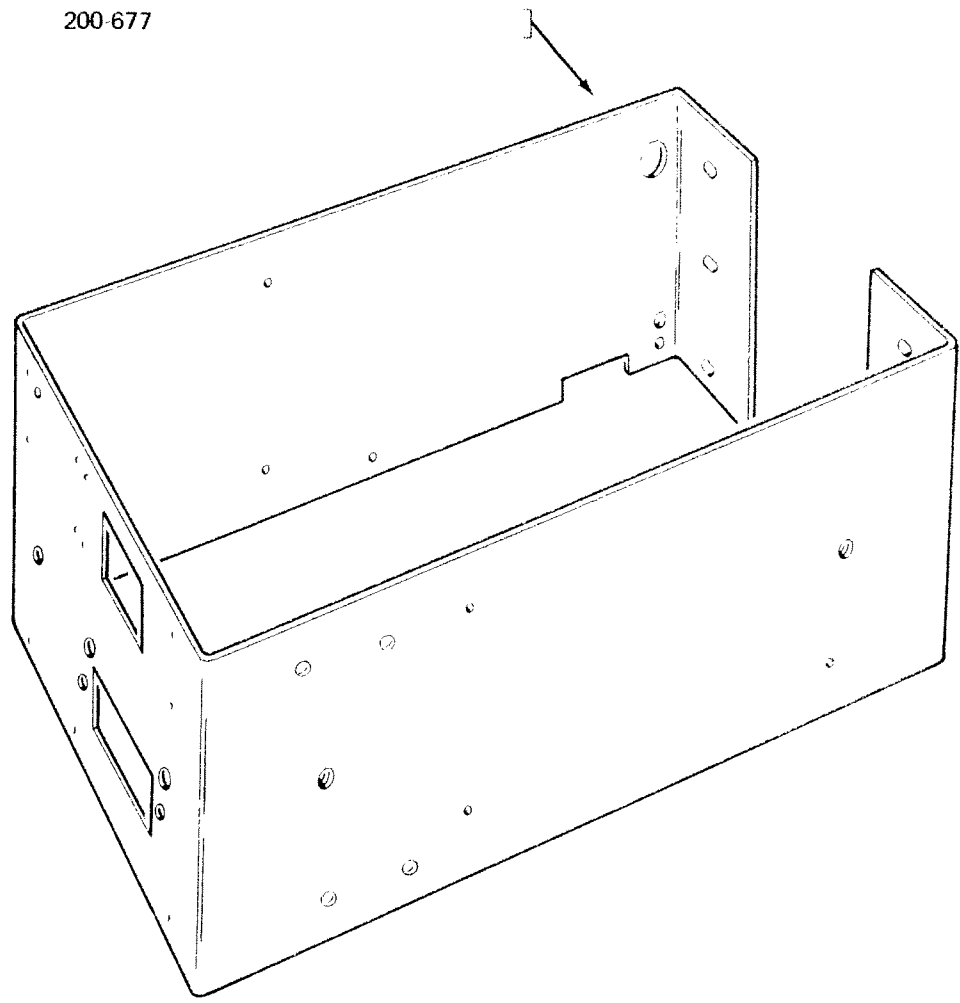

<i>Z</i> 1	Left side panel	203-1544	
------------	-----------------	----------	--

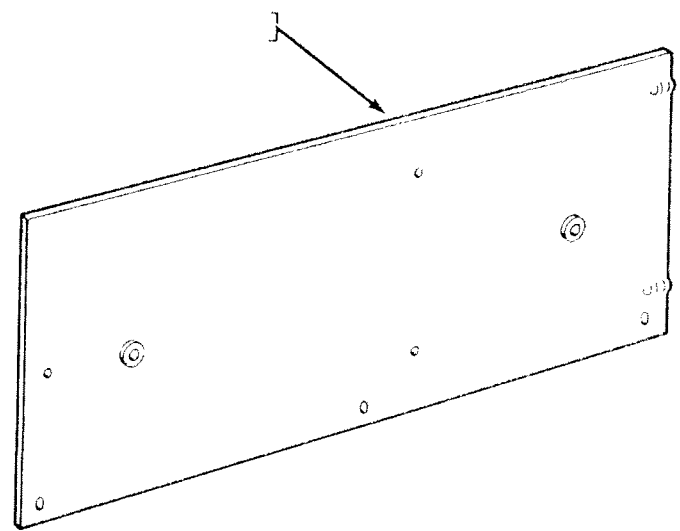

QTY.	DESCRIPTION	PART No.	CIRCUIT Component No.
------	-------------	----------	-----------------------

Metal Parts (cont'd.)

(X)	1	Rear panel	203-1646
----------------	---	------------	----------

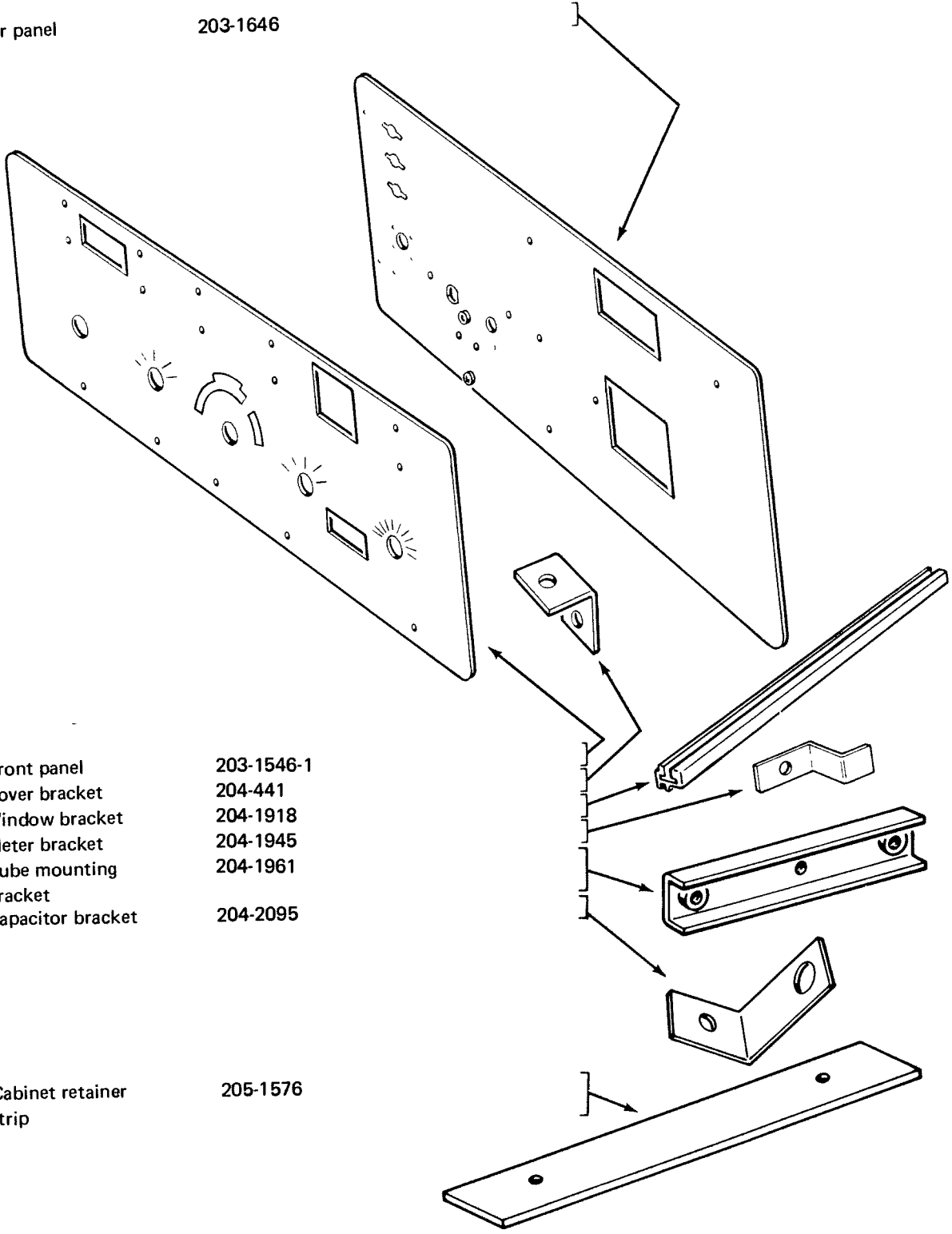

(X)	1	Front panel	203-1546-1
()	2	Cover bracket	204-441
()	2	Window bracket	204-1918
()	2	Meter bracket	204-1945
()	1	Tube mounting bracket	204-1961
()	1	Capacitor bracket	204-2095

()	2	Cabinet retainer strip	205-1576
-----	---	------------------------	----------

QTY.	DESCRIPTION	PART No.	CIRCUIT Component No.
------	-------------	----------	-----------------------

Metal Parts (cont'd.)

()	1	Lower panel trim strip	205-1432-2
(X)	1	Perforated cover	205-1536

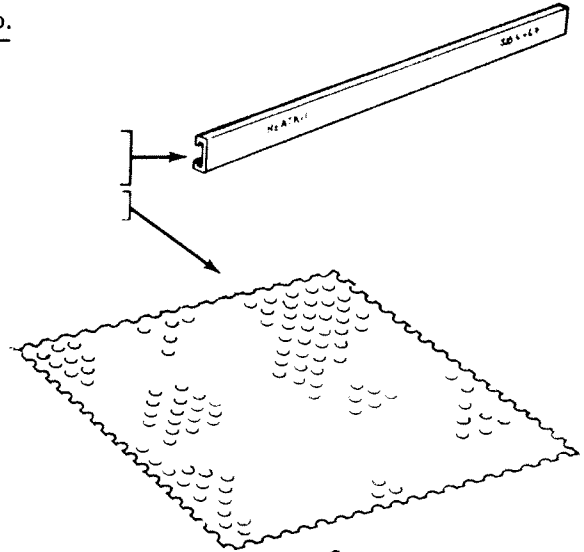

()	1	Switch plate	205-1553
(X)	1	Heat sink	215-74

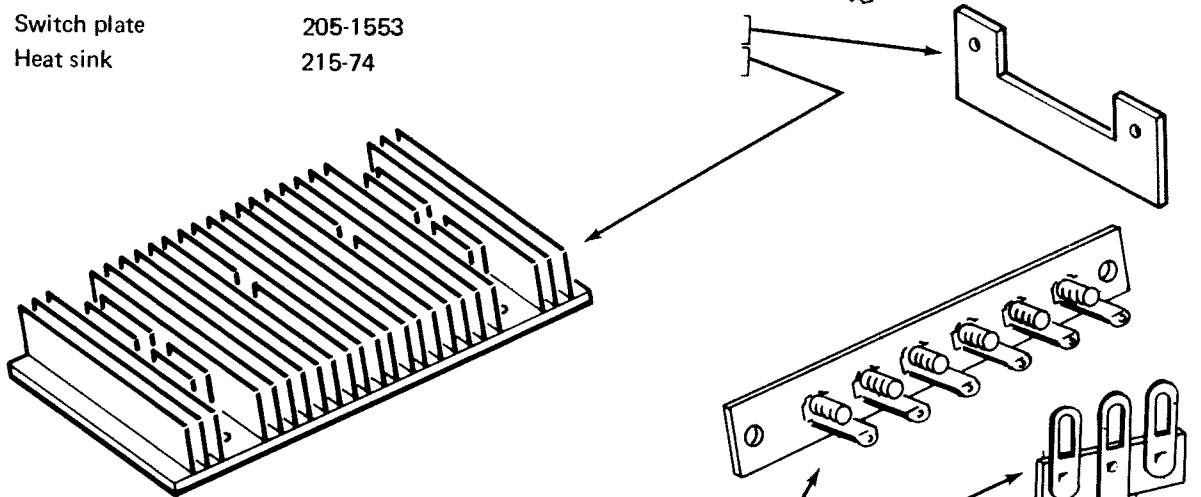

TERMINAL STRIPS

()	1	6-screw	431-7
()	1	3-lug	431-10
()	1	4-lug	431-12
()	1	2-lug	431-14
()	1	1-lug	431-26
()	1	4-lug	431-40
()	1	5-lug	431-42
()	1	6-lug	431-45
()	1	6-lug	431-55

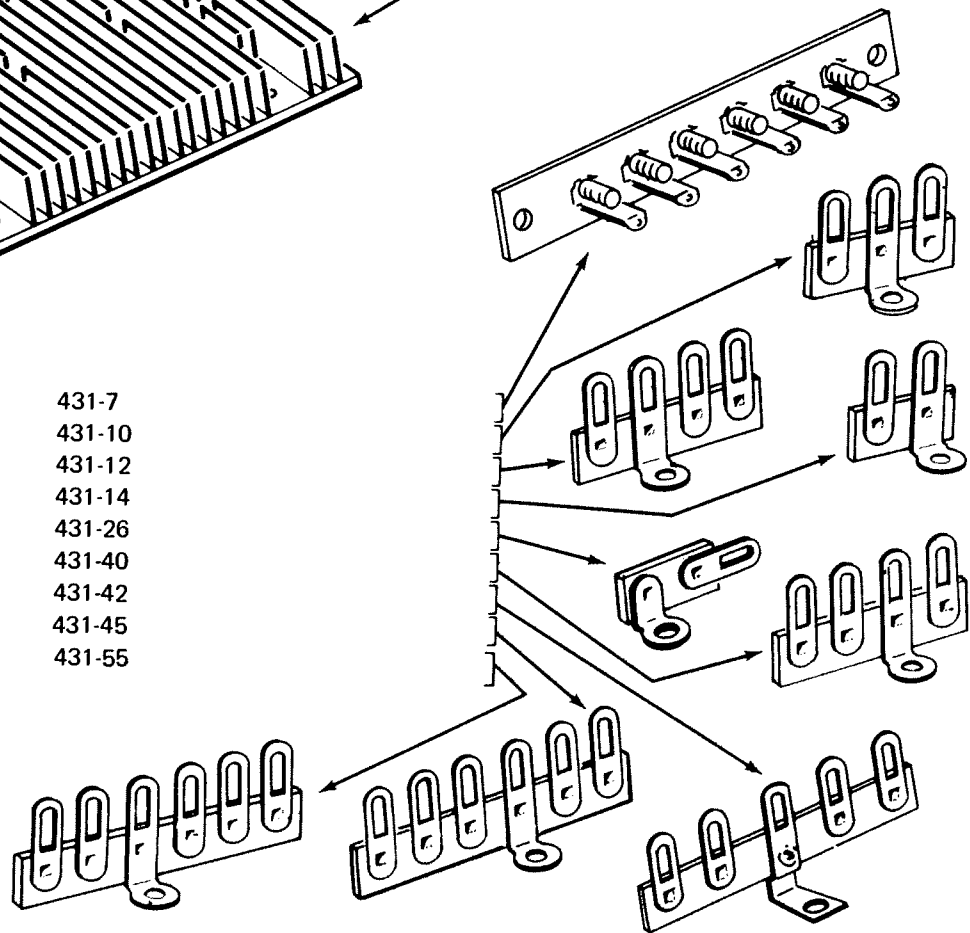

QTY.	DESCRIPTION	PART No.	CIRCUIT Component No.
------	-------------	----------	-----------------------

Terminal Strips (cont'd.)

()	2	30-lug terminal board	431-69
-----	---	-----------------------	--------

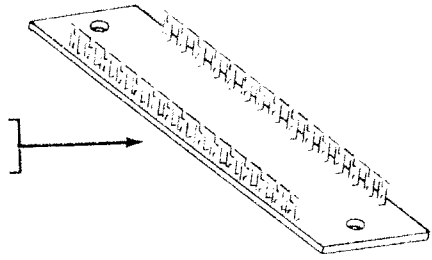

CONNECTORS

()	10	Female connector	432-120
()	4	Push-on connector	432-137
()	3	Phono socket	434-42
()	1	9-pin socket	434-56
()	1	Female coaxial connector	436-5
()	3	Phono plug	438-4
()	1	Coaxial plug	438-9
X	1	Coaxial insert	438-12

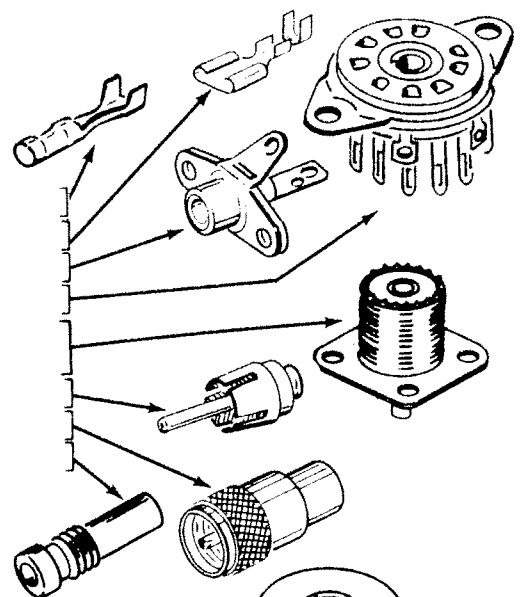

MISCELLANEOUS

X	1	Power transformer	54-847
X	1	Tube plate clamp	260-82
X	4	Rubber foot	261-9
X	2	Black tapered foot	255-59
X	1	Lamp housing	266-824
X	1	Lamp socket	434-88
X	2	Silver plated grid strap	212-45

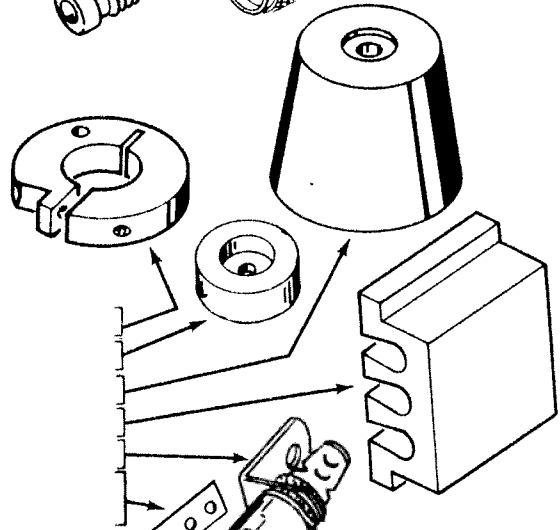

T1

X	1	Large knob	462-934
---	---	------------	---------

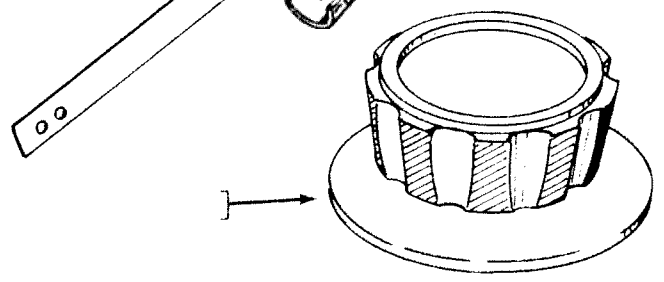

QTY.	DESCRIPTION	PART No.	CIRCUIT Component No.
------	-------------	----------	-----------------------

Miscellaneous (cont'd.)

(X)	4	Small knob	462-933	
(-)	3	Shaft coupler	456-7	
(-)	1	4-3/8" extension shaft	453-35	
(-)	2	4-3/4" extension shaft	453-29	

(-)	1	Diffuser strip	446-644	
(-)	1	Window	446-628-1	
(-)	1	Fuseholder	423-2	
(-)	1	3/4 ampere, 3AG slow-blow fuse	421-29	F1
(-)	1	#1820 lamp	412-47	PL1
(-)	1	Lamp shield	206-86	
(-)	1	Type 8873 tube. Be sure to save the tube manufacturer's warranty packed with the tube.	411-298	V1
(X)	1	Meter	407-185	M1
(-)	2	Cable tie	354-6	
(-)	3	Thermal compound pod	352-31	
(-)	1	Nut starter	490-5	
(-)	1	Wrench	490-168	

PRINTED MATERIAL

(-)	1	Danger label	390-147
(-)	1	Blue and white label	391-34
(-)	1	Parts Order Form	597-260
(-)	1	Kit Builders Guide	597-308
(-)	1	Manual (See front cover for part number.)	

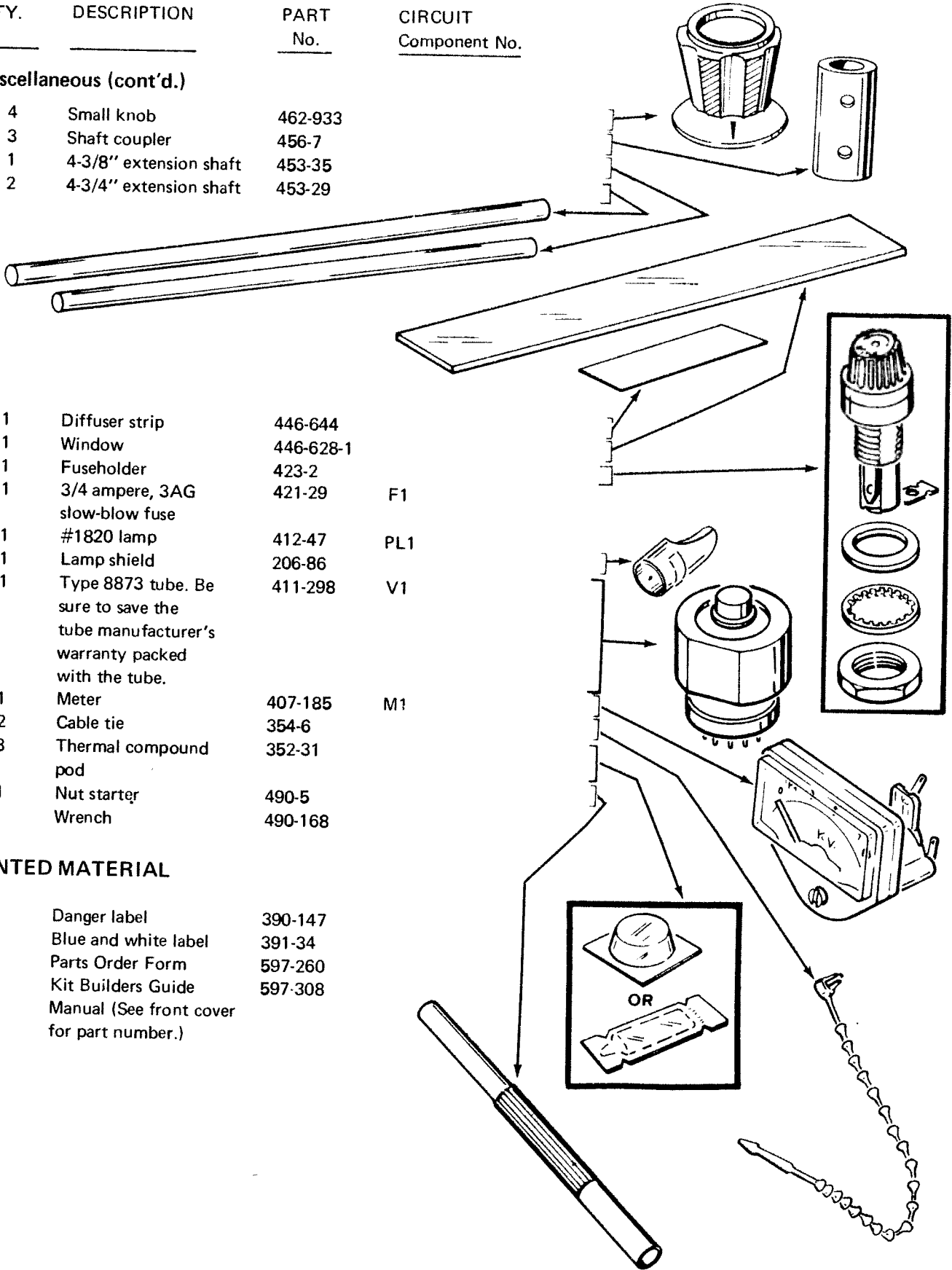



STEP-BY-STEP ASSEMBLY

The illustrations in this section of the Manual are called Pictorials and Details. Pictorials show the overall operation for a group of assembly steps; Details are used in addition to the Pictorials to illustrate a single step. When you are directed to refer to a certain Pictorial "for the following steps," continue using that Pictorial until you are referred to another Pictorial for another group of steps.

As the drawings in the Manual may be slightly distorted to show all the parts clearly, look at the "Chassis Photos" (Page 109) from time to time to see the actual positions of wires and components.

Lockwashers and nuts will be used with most screws when you are mounting parts, unless the assembly steps state otherwise. Consequently, the applicable steps will call out only the size and type of hardware used. For example, the phrase "Use 6-32 x 1/4" hardware" means to use 6-32 x 1/4" screws, one or more #6 lockwashers, and 6-32 nuts. Refer to the Details for the proper installation of hardware. Be sure to position each part as shown in the Pictorials. Follow the instructions carefully, and read the entire step before performing the operation.

When a step directs you to "connect" an insulated wire, first prepare its ends by removing 1/4" of insulation.

RF CHASSIS

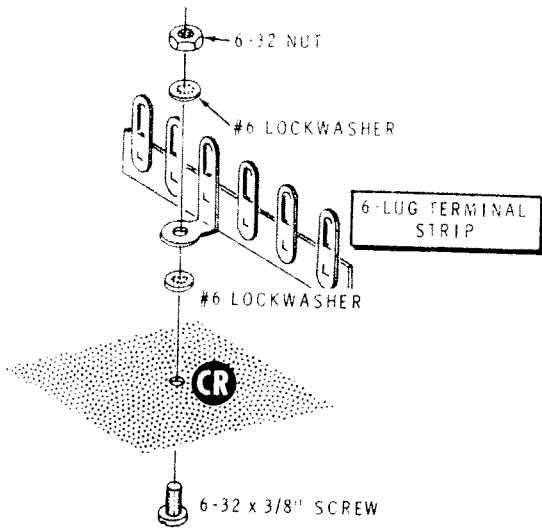

Detail 4A

Refer to Pictorial 4 on Page 31 for the following steps.

NOTE: Use the nut starter provided with this kit to hold and start 6-32 and 4-40 nuts on screws.

(X) Refer to Detail 4A and mount a 6-lug terminal strip in hole CR on the bottom of the RF chassis. Use 6-32 x 3/8" hardware. Position the terminal strip as shown and then tighten the screw from the top side of the chassis. This is terminal strip TA.

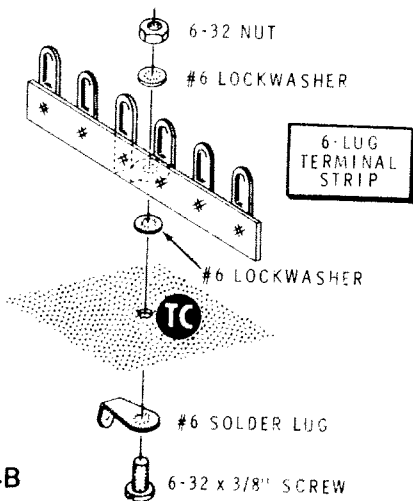

Detail 4B

(X) Refer to Detail 4B and mount a 6-lug terminal strip in hole TC. Use 6-32 x 3/8" hardware and a #6 solder lug (under the screw head).

(X) Mount a 4-lug terminal strip in hole TD. Use 6-32 x 3/8" hardware. DO NOT use a solder lug with this terminal strip.

(X) Refer to Detail 4C and mount a small plastic grommet in hole CL. Be sure the grommet is seated flush against the chassis.

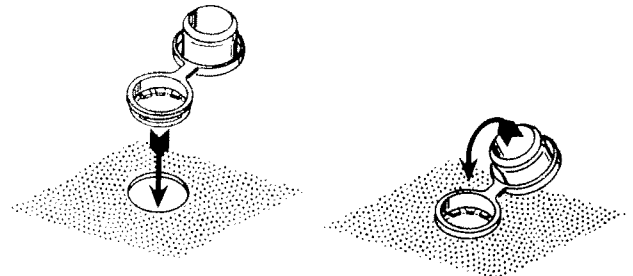

POSITION THE SMALL PORTION OF THE GROMMET OVER THE CHASSIS HOLE.

BEND THE LARGE PORTION OF THE GROMMET OVER AND INTO THE SMALL PORTION. PRESS IT FIRMLY INTO PLACE.

Detail 4C

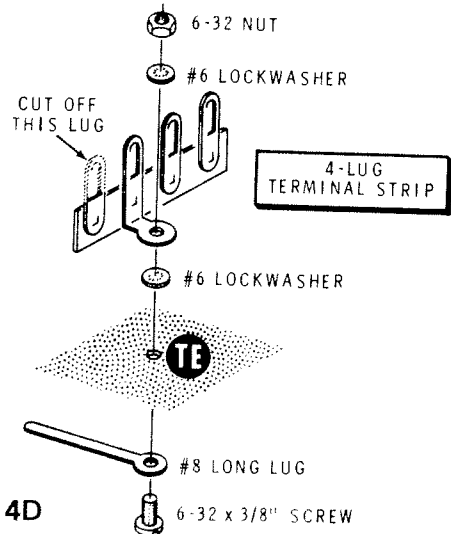

Detail 4D

Refer to Detail 4D for the following two steps.

(X) Cut off the lug shown. Be sure you select the correct lug.

(X) Mount the 4-lug terminal strip in hole TE. Use 6-32 x 3/8" hardware with a #8 long lug (under the screw head).

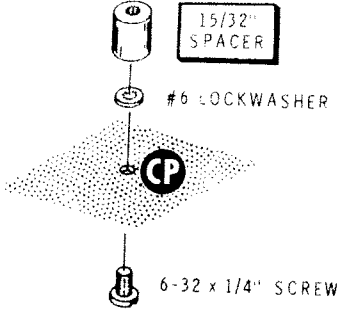

(A) Refer to Detail 4E and mount a 15/32" long spacer at hole CP. Use a 6-32 x 1/4" screw.

(A) Similarly, mount a 15/32" long spacer at hole CN with a 6-32 x 1/4" screw.

Detail 4E

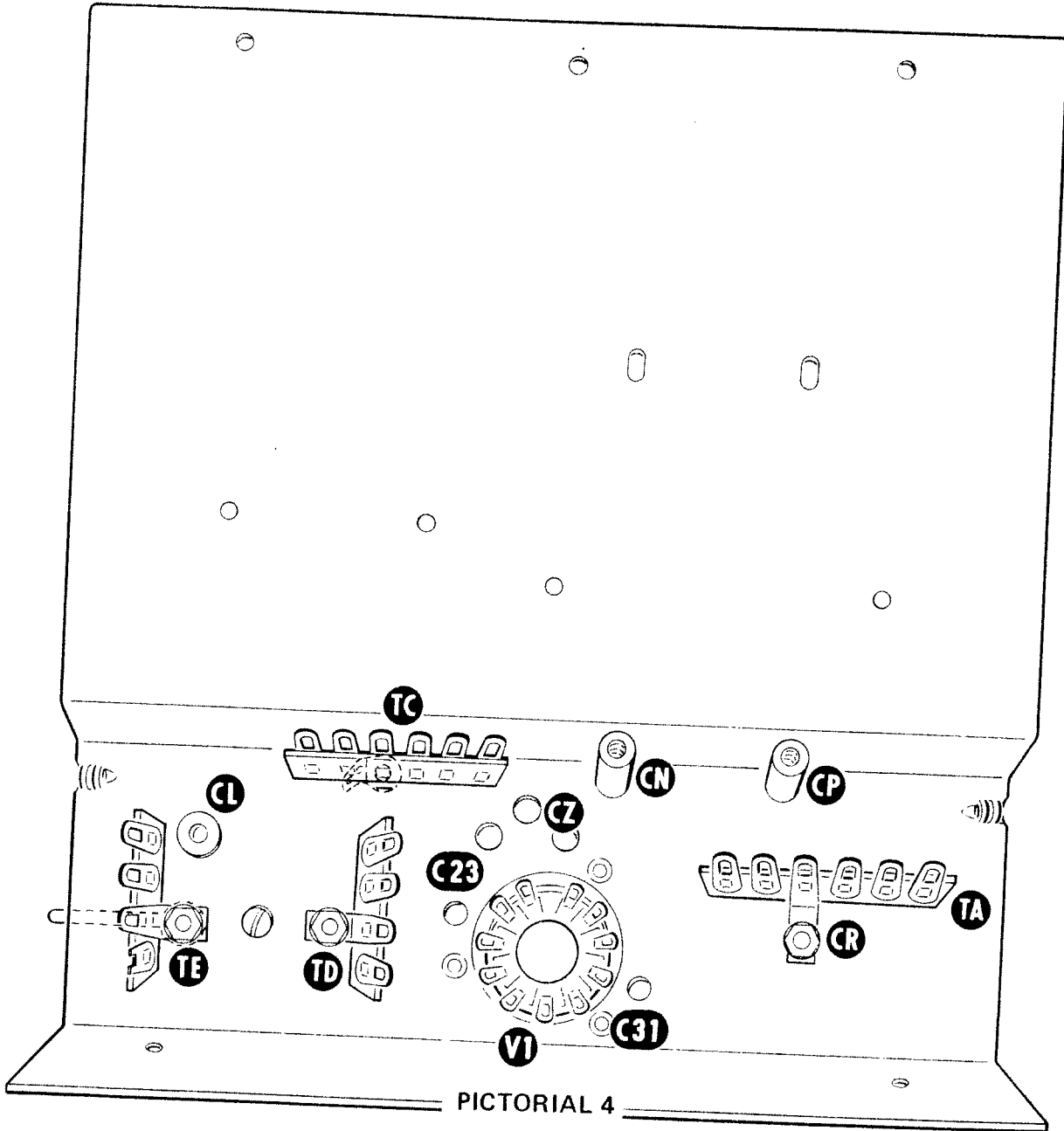

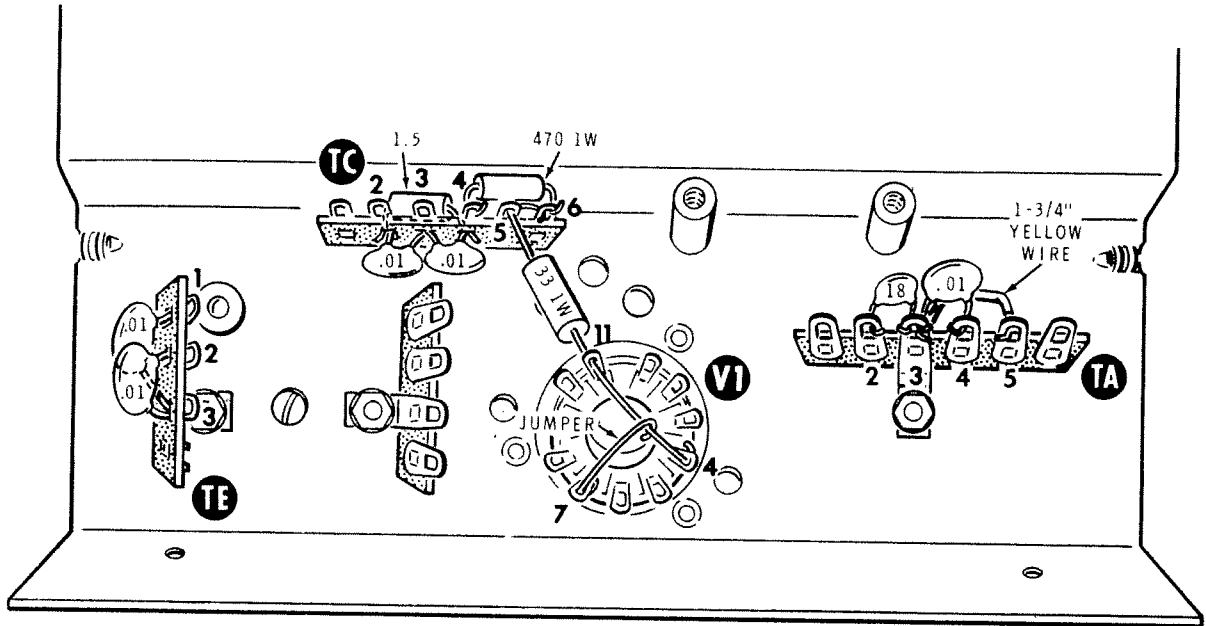

PICTORIAL 5

Refer to Pictorial 5 for the following steps.

NOTE:

1. You will be instructed to insert component leads and wires into the "lower" holes of terminal strip lugs in some of the following steps. Detail 5A shows the "lower" and the "upper" holes of the terminal strip solder lugs. Always use the upper holes unless you are specifically instructed to use the lower holes.
2. When you are instructed to "push a lead down against the insulator strip," position it as shown in Detail 5A.
3. Save four of the capacitor leads that you cut off in the following steps. They will be used to wire socket V1.

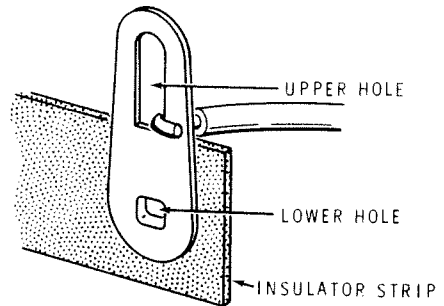

Detail 5A

4. For clarity, the following Pictorials will usually show the position of components after they have been mounted; other parts, not shown, may have been previously mounted.



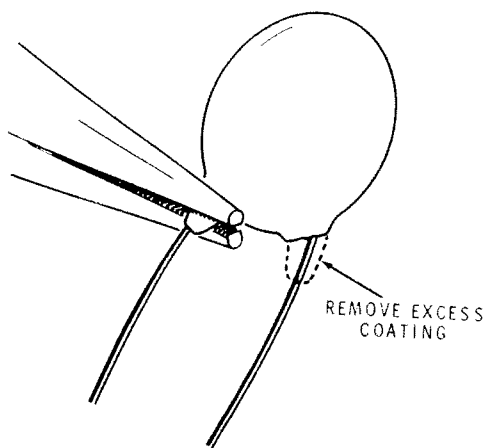

Detail 5B

5. Before you install a disc capacitor, refer to Detail 5B and remove any excess coating from its leads by exerting a small amount of pressure with pliers and then twisting the lead. This excess coating could otherwise interfere with soldering when a capacitor is installed with very short leads.
 6. To "prepare" an insulated wire, cut it to the specified length and then remove 1/4" of insulation from each end. If the wire is stranded, twist the fine strands at each end tightly together and then melt a minimum amount of solder on the bare wire.
 7. To avoid confusion with lower voltage capacitors, temporarily lay aside the following high voltage disc capacitors. Use them only when these voltage ratings are specified in a step:
 - 1 .001 μ F, 6000 volt (6 KV) disc capacitor
 - 2 .01 μ F, 1400 volt (#21-70) disc capacitor
 - 1 .02 μ F, 1600 volt (1.6 KV) disc capacitor
- Prepare a 1-3/4" yellow wire.
 - Connect the yellow wire to terminal strip TA between lug 3 (NS) and lug 5 (NS). Push the wire down against the insulator strip.

C24: Connect an 18 pF disc capacitor to terminal strip TA from lug 2 (NS) to lug 3 (NS).

C25: Connect a .01 μ F disc capacitor to terminal strip TA from lug 3 (NS) to lug 4 (NS).

NOTE: When a wire passes through a connection and then goes to another point, as in the next step, it will count as two wires in the solder instructions (S-2), one entering and one leaving the connection. Be especially careful, when soldering these connections, to apply enough solder and heat to solder these "through wires."

R17: Connect one lead of a 33 Ω , 1-watt (orange-orange-black) resistor to socket V1. Push the lead through lug 11 (S-2) to lug 4 (NS). Connect the other lead of this resistor to terminal strip TC. Push the lead through lug 5 (S-2) to lug 6 (NS).

NOTE: Use the four cut-off capacitor leads for wiring socket V1 in the following steps.

Form a small hook at one end of a cut-off capacitor lead. Place this hook over the midpoint of the wire in the preceding step (S-1). Connect the other end of this wire to lug 7 (S-1) of the socket.

C17: Connect a .01 μ F disc capacitor to terminal strip TC between the lower hole of lug 2 (NS) and the lower hole of lug 3 (NS).

C19: Connect a .01 μ F disc capacitor to terminal strip TC between the lower hole of lug 3 (S-2) and the lower hole of lug 4 (NS).

R25: Connect a 1.5 Ω (brown-green-gold) resistor to terminal strip TC between the lower hole of lug 2 (S-2) and the lower hole of lug 4 (S-2).

R16: Connect a 470 Ω , 1-watt (yellow-violet-brown) resistor to terminal strip TC between lugs 4 (NS) and 6 (NS).

C29: Connect a .01 μ F disc capacitor to terminal strip TE between the lower hole of lug 1 (S-1) and the lower hole of lug 3 (NS).

C28: Connect a .01 μ F disc capacitor to terminal strip TE between the lower hole of lug 2 (S-1) and the lower hole of lug 3 (S-2).

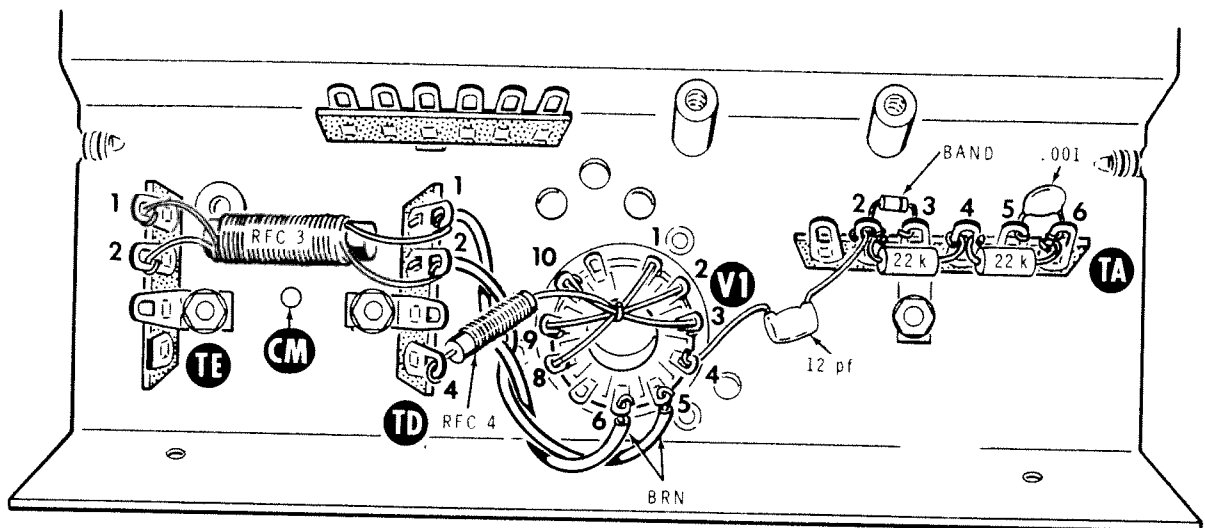

PICTORIAL 6

Refer to Pictorial 6 for the following steps.

- (X) Connect a cut-off lead between socket lugs 1 (S-1) and 8 (S-1). Before soldering, curve this wire up at its midpoint so it clears the wires below it by at least 1/8".
- (X) Connect a cut-off lead between socket lugs 2 (NS) and 9 (S-1). Position this wire so it passes over, and touches, the wire in the preceding step.
- (X) Connect a cut-off lead between socket lugs 3 (S-1) and 10 (S-1). Position this wire so it passes over, and touches, the wire in the preceding step.
- (X) D19: Connect the lead at the unbanded end of a type 1N458 diode (#56-24) to terminal strip TA lug 2 (NS), and connect the lead at the banded end to lug 3 (S-4).
- (X) C26: Connect a .001 μF disc capacitor to terminal strip TA from lug 5 (S-2) to lug 6 (NS).
- (X) R19: Connect a 22 $\text{k}\Omega$ (red-red-orange) resistor to terminal strip TA from lug 4 (NS) to lug 6 (NS).
- (X) R18: Connect a 22 $\text{k}\Omega$ (red-red-orange) resistor to terminal strip TA from lug 2 (NS) to lug 4 (S-3).
- (X) C22: Connect one lead of a 12 pF mica capacitor to terminal strip TA lug 2 (S-4). Connect the other lead to socket V1 lug 4 (S-2).

TWISTED PAIR



Detail 6A

- (X) Prepare two 3" lengths of large brown (stranded) wire. Then refer to Detail 6A and form the two wires into a twisted pair.
 - (X) At one end of the twisted pair, connect one wire to socket V1 lug 5 (S-1), and connect the other lead to lug 6 (S-1).
 - (X) Connect the other end of the twisted pair to terminal strip TD: one wire to the lower hole of lug 1 (S-1) and the other lead to the lower hole of lug 2 (S-1).
 - (X) RFC 4: Connect one lead of an 8.5 μH RF choke (#45-6) to terminal strip TD lug 4 (NS). Wrap the other lead of the choke around the three wires which cross at the midpoint of socket V1. Solder all four wires together.
- NOTE: In the following step, position the RF choke so it clears the chassis by 1/4". Its position must also permit insertion (later) of a 6-32 screw in hole CM.
- (X) RFC 3: Connect the two leads at one end of a 13.5 μH RF choke (#45-58) to terminal strip TE lug 1 (NS) and lug 2 (NS). Connect the two leads at the other end of the choke to terminal strip TD lug 1 (NS) and lug 2 (NS). Make sure the choke is positioned as described in the note.

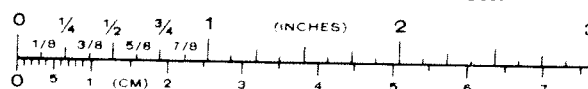

Refer to Pictorial 7 for the following steps.

- (X) C32: Connect a .02 μ F, 1.6 kV, disc capacitor from socket V1 lug 2 (S-2) to terminal strip TA lug 1 (NS). Position this capacitor as shown. It must clear the chassis by 1/4" to allow passage of a coaxial cable to be installed later. Push the lead on lug 1 down against the insulator strip.
- (X) C27: Connect a .02 μ F capacitor to terminal strip TD between lugs 1 (S-2) and 2 (S-2).
- (X) C33: Connect a .02 μ F disc capacitor to terminal strip TD between lugs 3 (S-1) and 4 (NS).

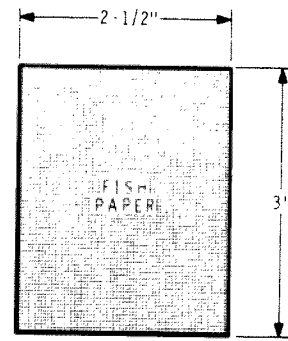

Detail 7B

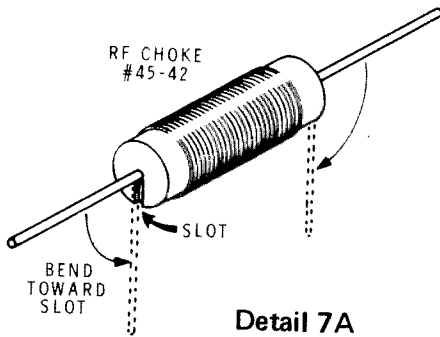

Detail 7A

- (X) Refer to Detail 7B and cut out a piece of fish paper 2-1/2" x 3".
- (X) Remove and discard the protective cover from the gray fish paper. Then, with the adhesive side toward the chassis, butt the 2-1/2" edge against the spacers at CN and CP and center the paper between holes CH and CJ. Then lower the paper and rub it firmly into place against the chassis.

- (X) RFC 1: Refer to Detail 7A and bend the leads of an 8.75 μ H RF choke (#45-42) toward the slot in the coil form. Then connect the RF choke to terminal strip TC between lugs 4 (NS) and 6 (S-3).
- (X) R33: Connect a 47 Ω (yellow-violet-black) resistor to terminal strip TC between lugs 1 (NS) and 4 (S-3).

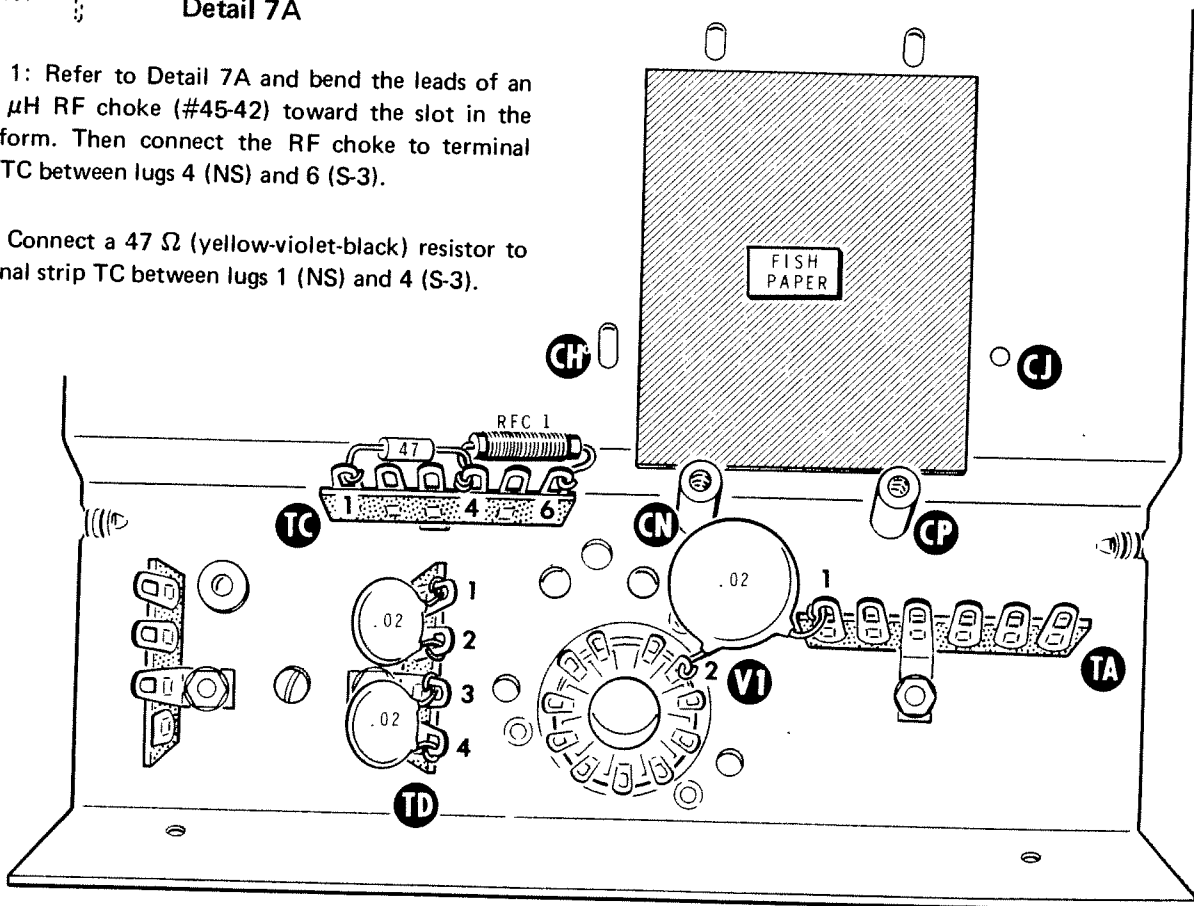

PICTORIAL 7

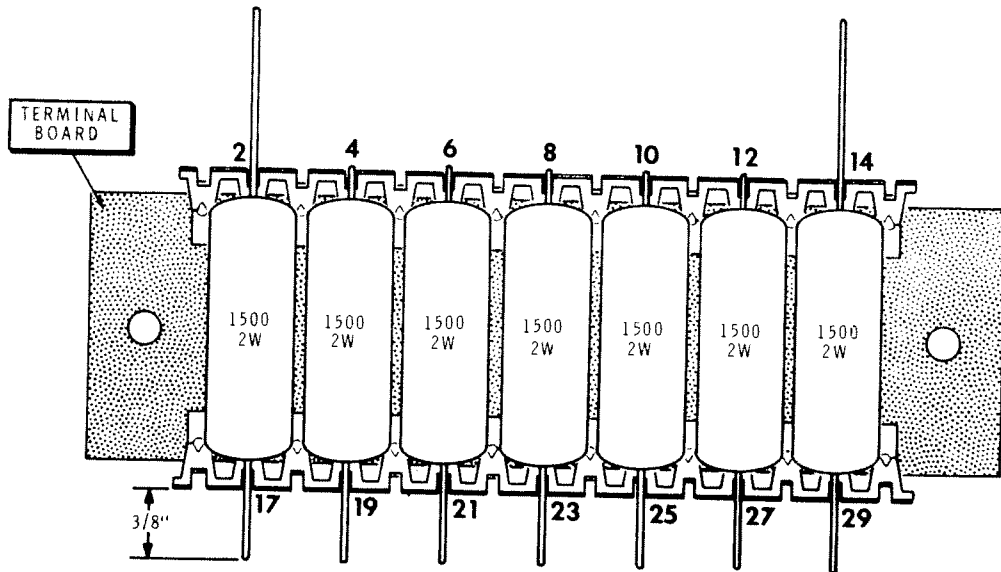

PICTORIAL 8

Refer to Pictorial 8 for the following steps.

~~N~~ Place a 30-lug terminal board before you and observe how the slots are numbered.

() Refer to Detail 8A for the following three steps. Place five 1500 Ω , 2-watt (brown-green-red) resistors with their leads in the following pairs of numbered slots.

4 and 19
6 and 21
8 and 23

10 and 25
12 and 27

Solder the leads to the terminals, but do not cut off any excess leads yet.

~~N~~ CAUTION: Cut off the excess lead lengths ONLY at terminals 4, 6, 8, 10 and 12.

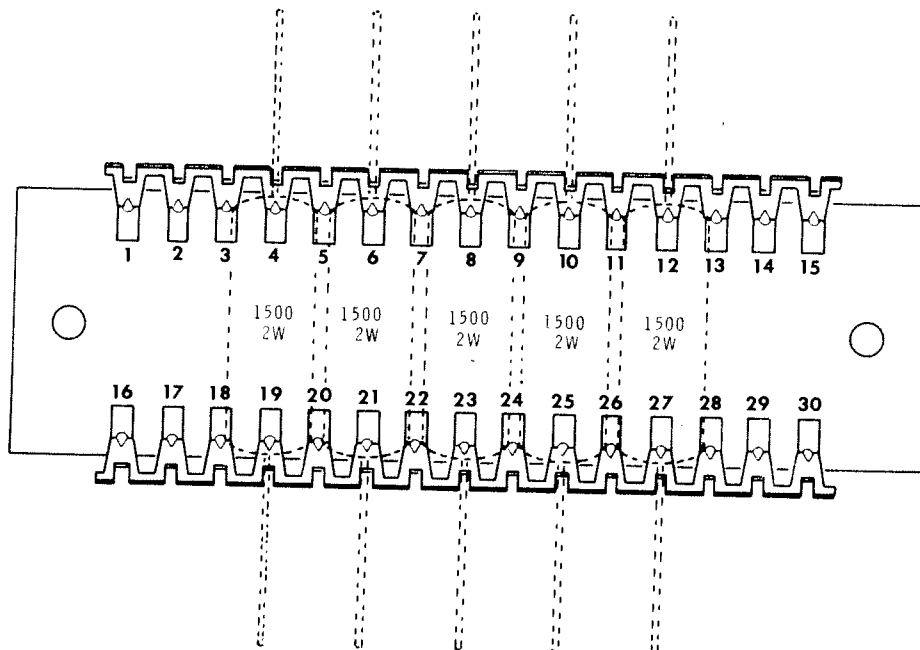

Detail 8A

(X) Place two 1500 Ω , 2-watt (brown-green-red) resistors with their leads in the pairs of slots at 2 and 17 and at 14 and 29. Solder the leads. DO NOT cut off the leads yet.

(X) Refer to Detail 8B and cut the resistor leads at terminals 17, 19, 21, 23, 25, 27 and 29 to 3/8" from the terminals.

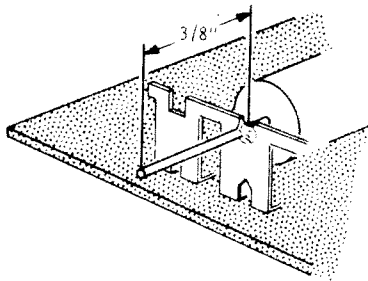

Detail 8B

Refer to Pictorial 9 for the following steps.

(X) On the remaining 30-lug terminal board, place six of the 1500 Ω , 2-watt (brown-green-red) resistors in the following pairs of numbered slots. Solder the leads.

- | | |
|----------|-----------|
| 3 and 18 | 9 and 24 |
| 5 and 20 | 11 and 26 |
| 7 and 22 | 13 and 28 |

(X) CAUTION: Cut off the excess lead lengths ONLY at terminals 18, 20, 22, 24, 26 and 28.

(X) Place two of the 1500 Ω , 2-watt (brown-green-red) resistors with their leads in the pairs of numbered slots at 1 and 16 and at 15 and 30. Solder the leads. DO NOT cut off the leads.

(X) Cut the leads at terminals 1, 3, 5, 7, 9, 11, 13 and 15 to 3/8" from the terminals.

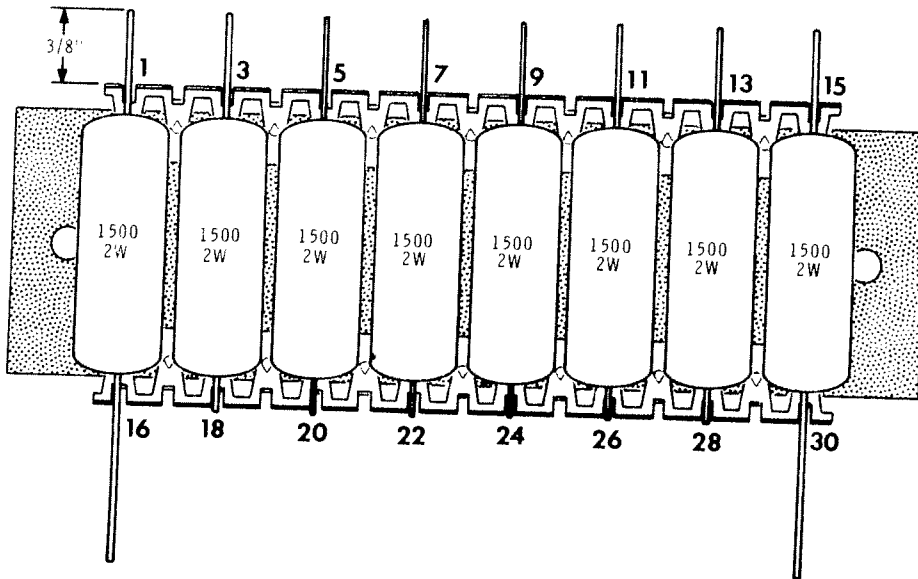

PICTORIAL 9

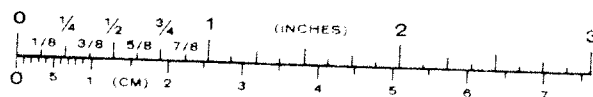

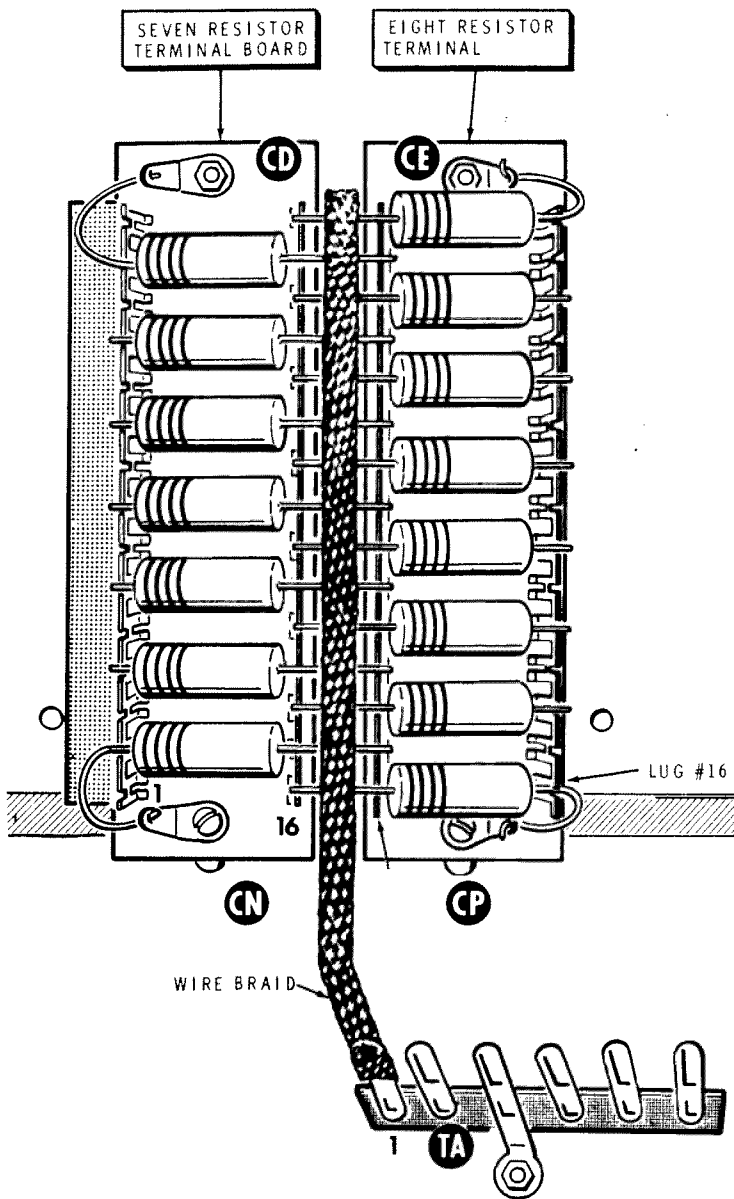

PICTORIAL 10

Refer to Pictorial 10 for the following steps.

Z R21: Refer to Detail 10A and mount the 30-lug terminal board with seven resistors at hole CD and spacer CN. Position terminals 1 and 16 of the circuit board toward the spacer. Use a #6 solder lug and a 6-32 x 1/4" screw at spacer CN. At hole CD, use a 6-32 x 3/8" screw inserted from the other side of the chassis, a #6 fiber washer, a #6 solder lug, and a 6-32 nut.

Z R18: Refer to Pictorial 10 and Detail 10B. Position the remaining 30-lug terminal board so its mounting holes are aligned with spacer CP and hole CE, its lugs 1 and 16 are toward the spacer, and the 3/8" lead of each resistor rests in the matching slot of the other terminal board, as shown in the Pictorial. Mount the terminal board with a #6 solder lug and a 6-32 x 1/4" screw in spacer CP. At hole CE use a #6 solder lug, a #6 fiber washer, a 6-32 x 3/8" screw, and a 6-32 nut.

Z Solder the remaining 15 unsoldered 3/8" resistor leads along the two middle rows of terminals. Let the solder run out onto the resistor leads between two center rows of terminals, as braid will be soldered to these leads later.

() Solder the four leads at the ends of the terminal boards to the four #6 solder lugs. Cut off the excess lead lengths.

Refer to Detail 10C and its inset drawing for the following two steps.

() Cut a 4-1/2" length of wire braid.

Z Open the end of the wire braid with a sharp instrument, such as the point of a knife blade (the braid is actually flattened, tubular braid). Slide the open end of the braid onto lug 1 of terminal strip TA (S-2).

Z Position the other end of the wire braid between the two middle rows of terminals and solder the braid to the 15 resistor leads. Use plenty of heat and solder. Check to make sure the braid is well soldered to the leads.

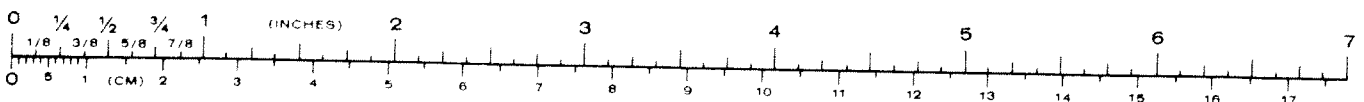

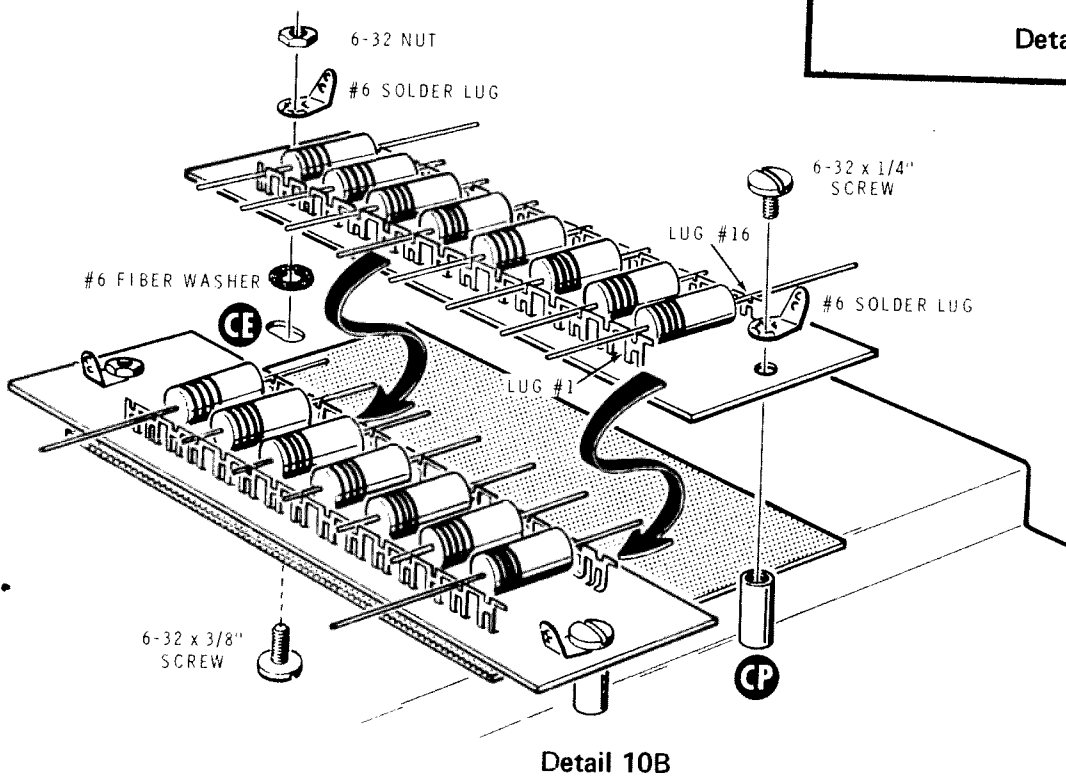
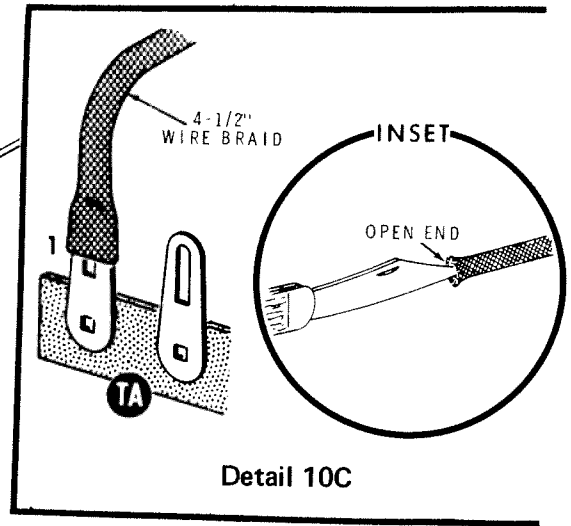
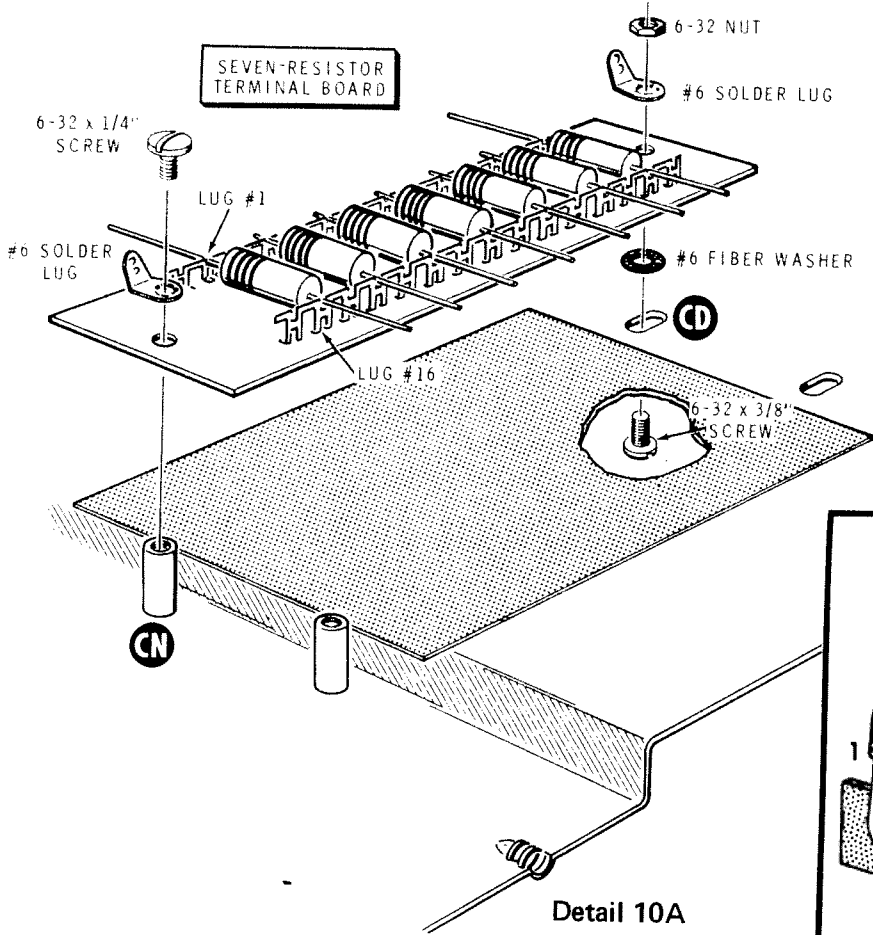

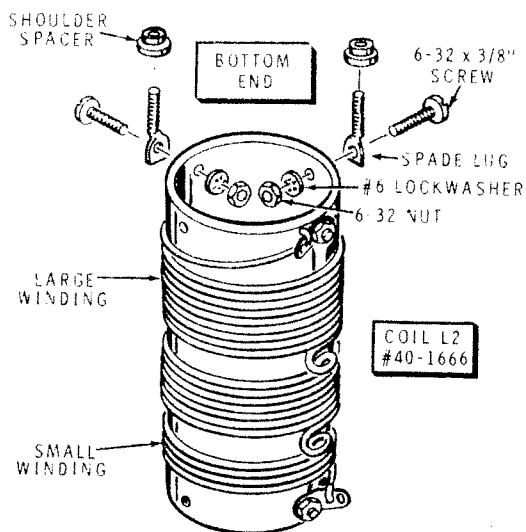

Detail 11A

Refer to Pictorial 11 for the following steps.

Refer to Detail 11A and install two spade lugs on the bottom of the 80-40-20 meters coil. Use a 6-32 x 3/8" screw, a #6 lockwasher, and a 6-32 nut for each spade lug. There are three holes at the large winding end of the coil form. Install the spade lugs in the two holes counterclockwise from the end of the coil when viewing the coil from the bottom. Note the position of the offset in the spade lugs.

With the larger end toward the coil, screw a 3/16" shoulder spacer (tapped 6-32) onto each spade lug as far as it will go.

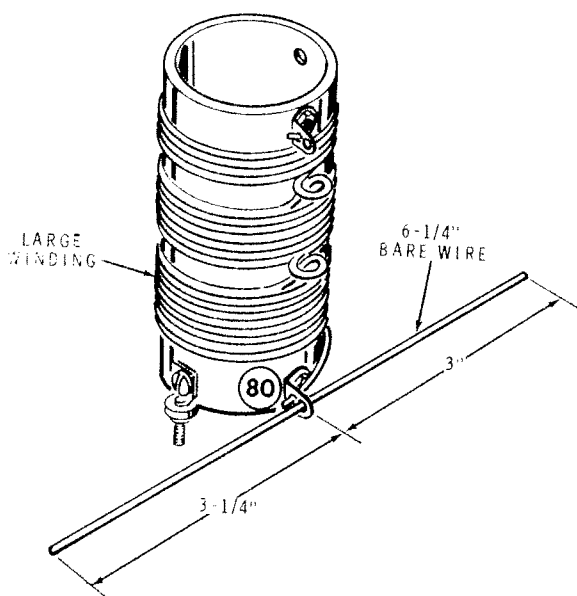

Detail 11B

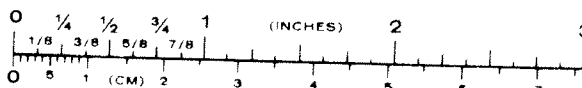

Refer to Detail 11B and position the coil with the large winding at the bottom, as shown. Push a 6-1/4" bare wire through the solder lug at 80 until the end of the wire is exactly 3" from the lug. Solder the wire to the lug.

L2: Refer to Detail 11C and mount the 80-40-20 meter coil at holes CG and CH. Use a #6 lockwasher and a 6-32 nut for each spade lug. Be sure the coil taps are facing directly away from the tube socket as shown in Pictorial 14.

NOTE: In the following step, refer to Pictorial 11 inset drawing and to Detail 11F for the location of hole CB.

Refer to Detail 11D and install a #6 solder lug at hole CB. Use a 6-32 x 1/4" screw and a 6-32 nut. Bend the solder lug up as shown.

Solder a 2" bare wire to the solder lug.

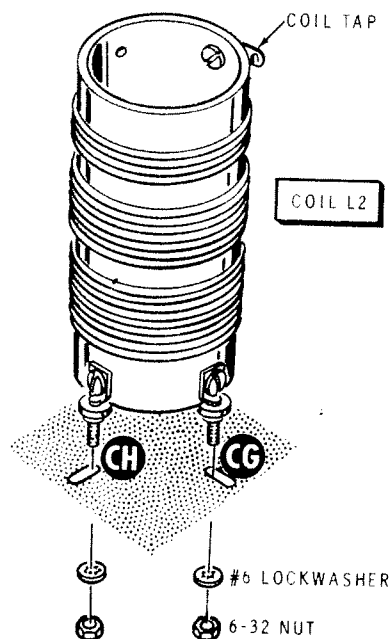

Detail 11C

NOTE: Refer to Detail 11E for the numbering of the 2-wafer switch solder lugs (SW3), as viewed from the rear. There are two switch lugs, one on each side of the wafer, at each position. Always solder a wire or lead to both lugs, and flatten the end of the wire with pliers so it will easily slides into the switch solder lugs.

C14: Refer to Detail 11E and mount a 500 pF mica capacitor (may be marked .0005) on the 2-wafer switch (SW3) between wafer 1 lug 1 (NS) and wafer 2 lug 1 (S-1).

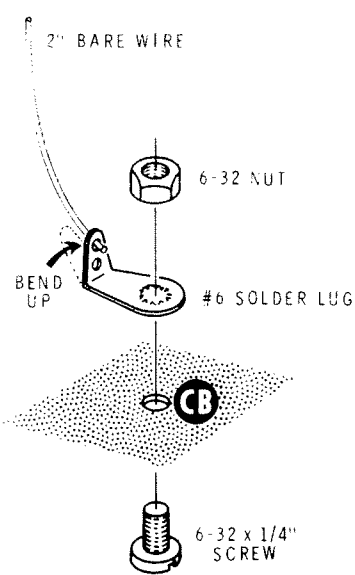

Detail 11D

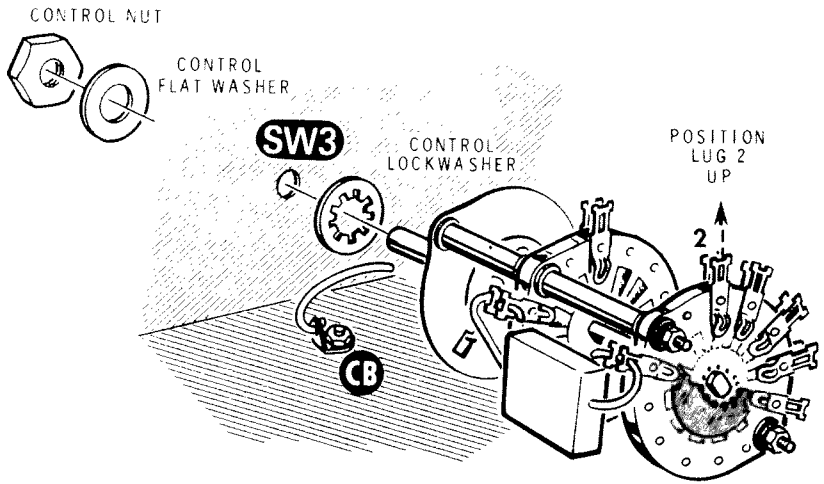

Detail 11F

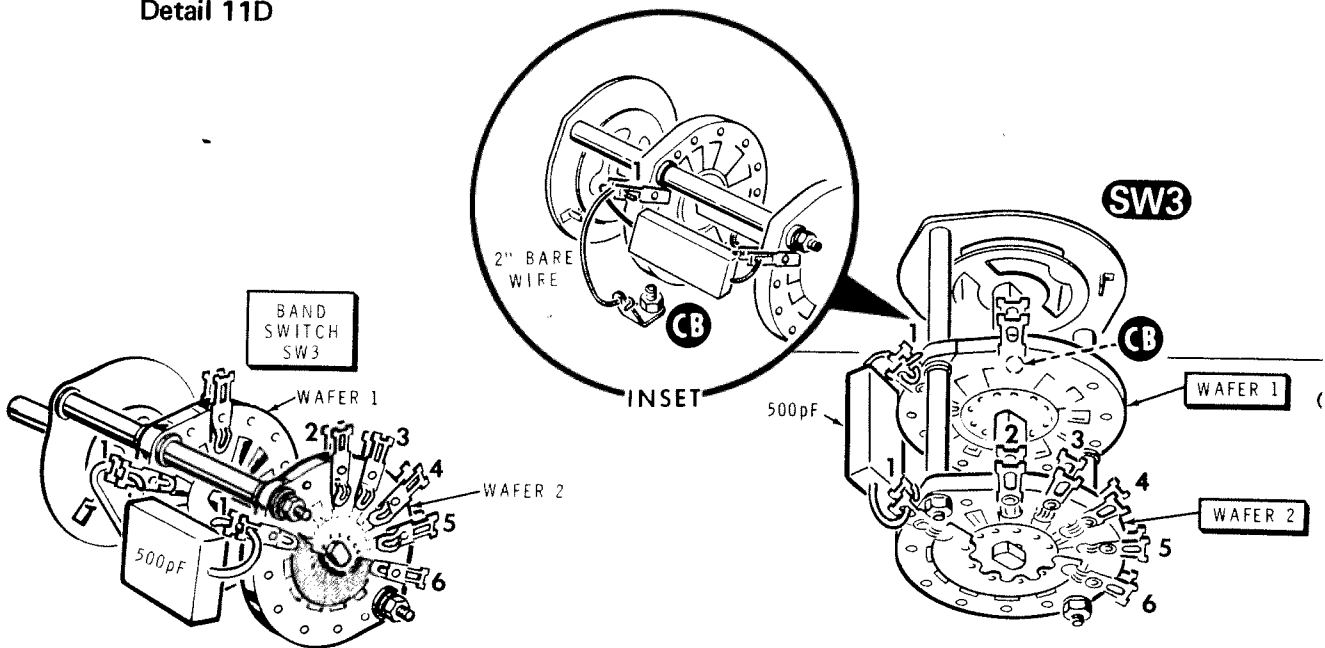

Detail 11E

SW3: Refer to Detail 11F and mount the 2-wafer switch in hole SW3. Use a control lockwasher, a control flat washer, and a control nut. Be sure to position the switch lugs as shown. As you position the switch, insert the end of the bare wire (coming from solder lug CB) between the two lugs of wafer 1 lug 1. After the switch is mounted, solder together the two switch lugs, the capacitor lead, and the bare wire. Cut off any excess length of bare wire.

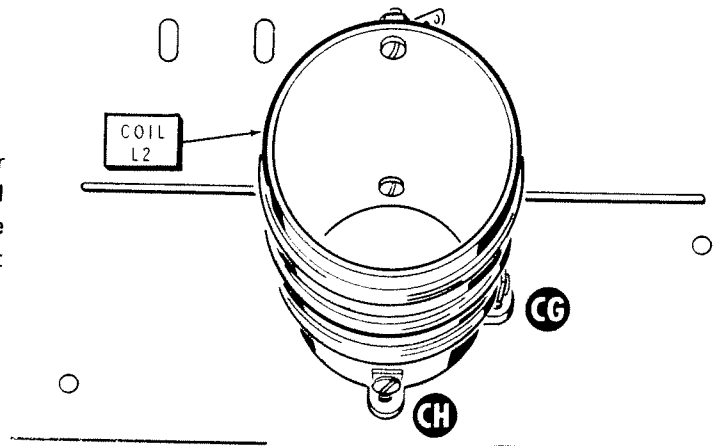

PICTORIAL 11

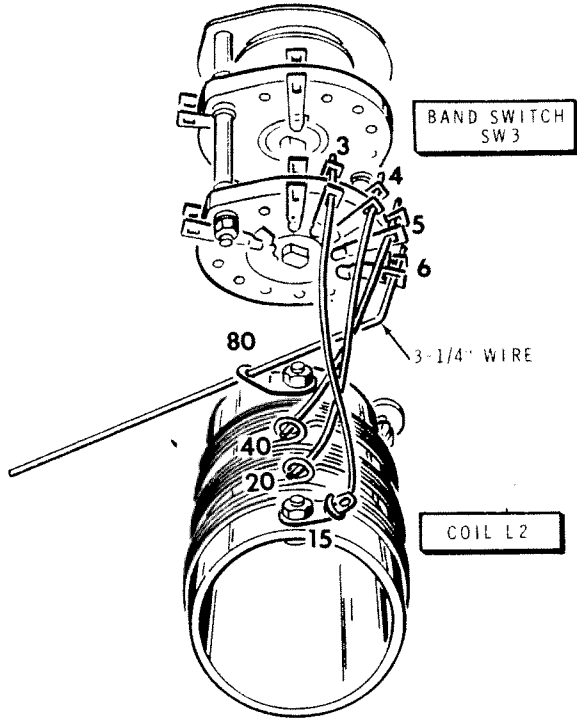

PICTORIAL 12

Refer to Pictorial 12 for the following steps.

CAUTION: Switch SW3 will be wired in the following steps. The large bare wire is stiff and the switch lugs can be easily bent. Therefore, **DO NOT** bend the bare wire with one end connected to the switch lugs, or the switch will probably be damaged. Form each wire so it fits, put it in position, and solder it in place. Flatten the ends of the wires with pliers so they will enter both switch lugs at each position.

- (X) Connect the 3-1/4" bare wire from the 80 coil tap to SW3 lug 6 (S-2).

In the following steps, connect bare wires from the designated lugs of wafer 2 of switch SW3 to the designated coil terminals.

Wire	Switch Lug	Coil Terminal
2-1/2"	5 (S-2)	40 (S-1)
2-3/4"	4 (S-2)	20 (S-1)
3"	3 (S-2)	15 (NS)

275

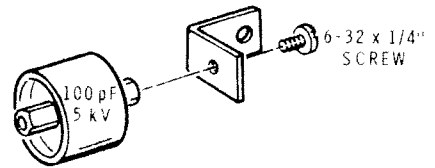

Detail 13A

- (N) Refer to Detail 13A and install the 100 pF 5 KV capacitor (may be marked 100 MMF) on the capacitor bracket with a 6-32 x 1/4" screw. Use the smaller hole.
- (X) C13: Refer to Detail 13B and mount the capacitor and bracket assembly on bolt BB on the shaft end of the 140 pF variable capacitor (#26-144). Use a 10-32 nut. If necessary, bend the bracket so the capacitor body does not touch any part of the band switch.

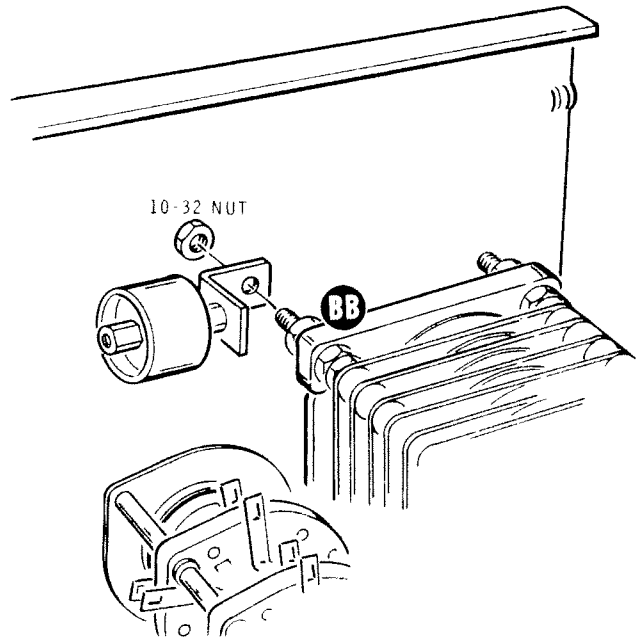

Detail 13B

Refer to Pictorial 13 (fold-out from Page 42) for the following steps.



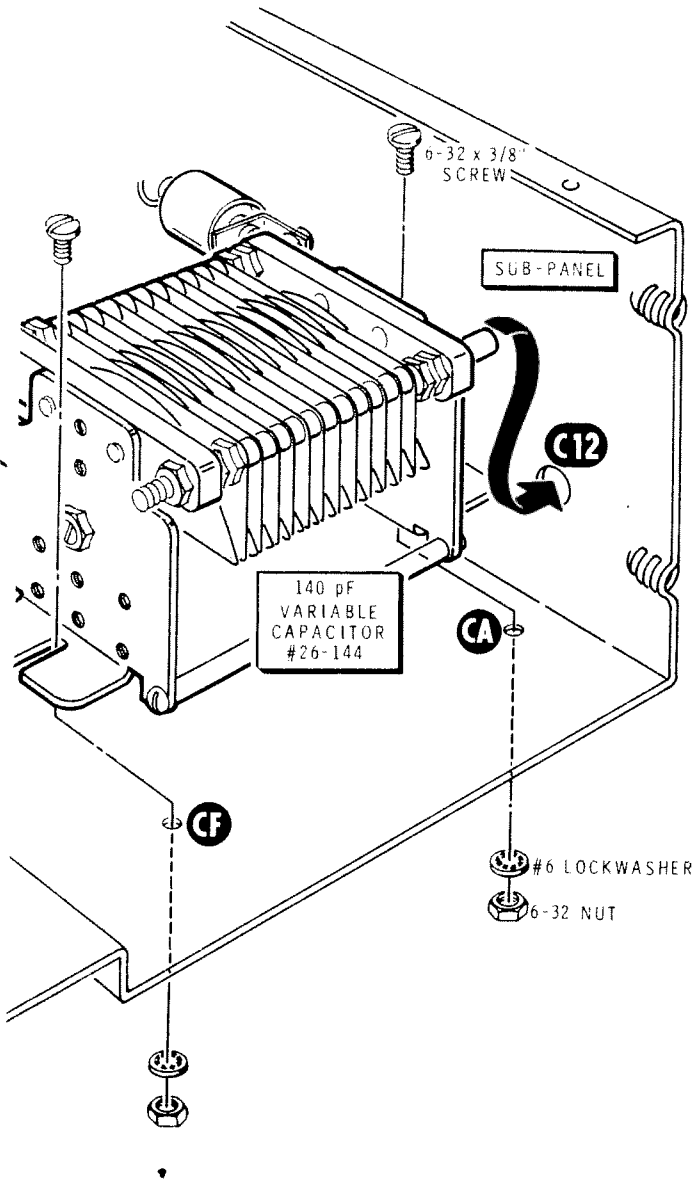

Detail 13C

- ✗ C12: Refer to Detail 13C and install the 140 pF variable capacitor (#26-144) at holes CA and CF with its shaft in subpanel hole C12. Use 6-32 x 3/8" hardware at each mounting hole.
- ✓ Refer to Detail 13D and make a loop in the end of a 2" wire to pass a 6-32 screw. Flatten the other end so it will enter both terminals of an SW3 switch lug.
- ✓ Connect the wire loop to the remaining terminal of C13, the 100 pF ceramic capacitor. Use a 6-32 x 1/4" screw. Solder the other end of the wire to SW3, wafer #1, lugs 2.

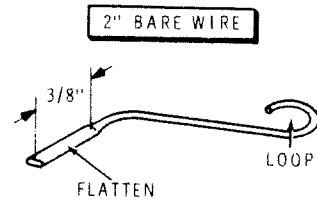

Detail 13D

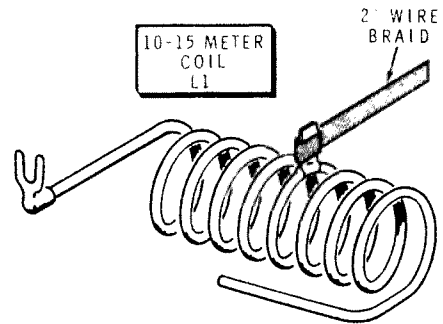

Detail 13E

- ✗ Refer to Detail 13E and solder a 2" length of wire braid to the tab on the 10-15 meter coil, L1.

Refer to Detail 13F (fold-out from page 42) for the next five steps.

- ✗ L1: Place two #6 flat washers and the solder lug of the 10-15 meter coil over stator plate screw BA of variable capacitor C12. Secure the solder lug with a 6-32 nut.
- ✗ L1: Carefully fit the 10-15 meter coil so it is parallel to both the subpanel and the chassis, and so the free end of the coil butts against the solder lug at L2 coil terminal 15 (S-2).
- ✗ Position the wire braid coming from the 10-15 meter coil tap so the braid passes between the two terminals at lug 2 of switch SW3. Solder the braid to both terminals.
- ✗ After the braid is connected and soldered, melt enough solder into the braid between the two connections to stiffen it.
- ✗ C11: Install a .001 μF ceramic capacitor (may be marked 1000 MMFD) on the stator bolt of variable capacitor C12 at BA. Turn the tapped capacitor snugly onto the bolt (the capacitor threads are 6-32).
- ✓ Install a #6 solder lug at BE on the other end of the ceramic capacitor. Use a 6-32 x 3/16" screw.

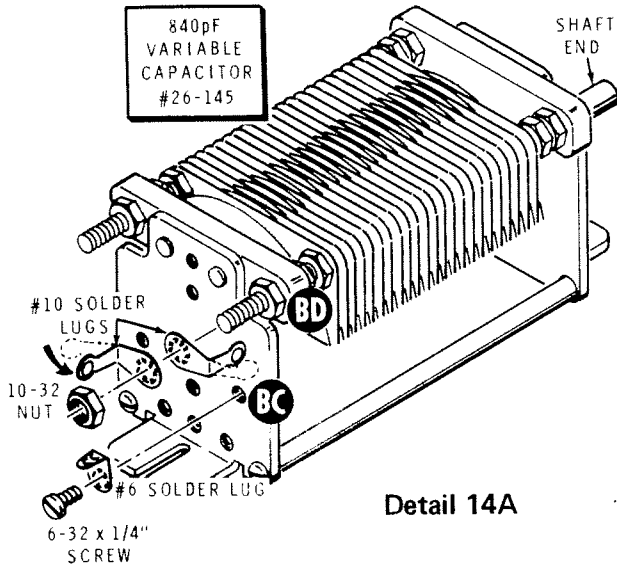

Detail 14A

Refer to Pictorial 14 for the following steps.

Refer to Detail 14A for the next two steps.

1. Mount a #6 solder lug on the rear frame of an 840 pF variable capacitor at BC. Use a 6-32 x 1/4" screw. After tightening the screw, bend the solder lug so it points to the rear.

2. Install two #10 solder lugs on the stator bolt of the 840 pF variable capacitor (#26-145) at BD. Use a 10-32 nut. Bend both lugs as shown.

3. C15: Refer to Detail 14B and mount the 840 μF variable capacitor at holes CC and CJ with its shaft in subpanel hole C15. Use 6-32 x 3/8" hardware at each mounting foot.

4. Solder the free end of the bare wire coming from the lower coil terminal to a solder lug at BD on variable capacitor C15. Be sure the wire does not touch any of the coil turns.

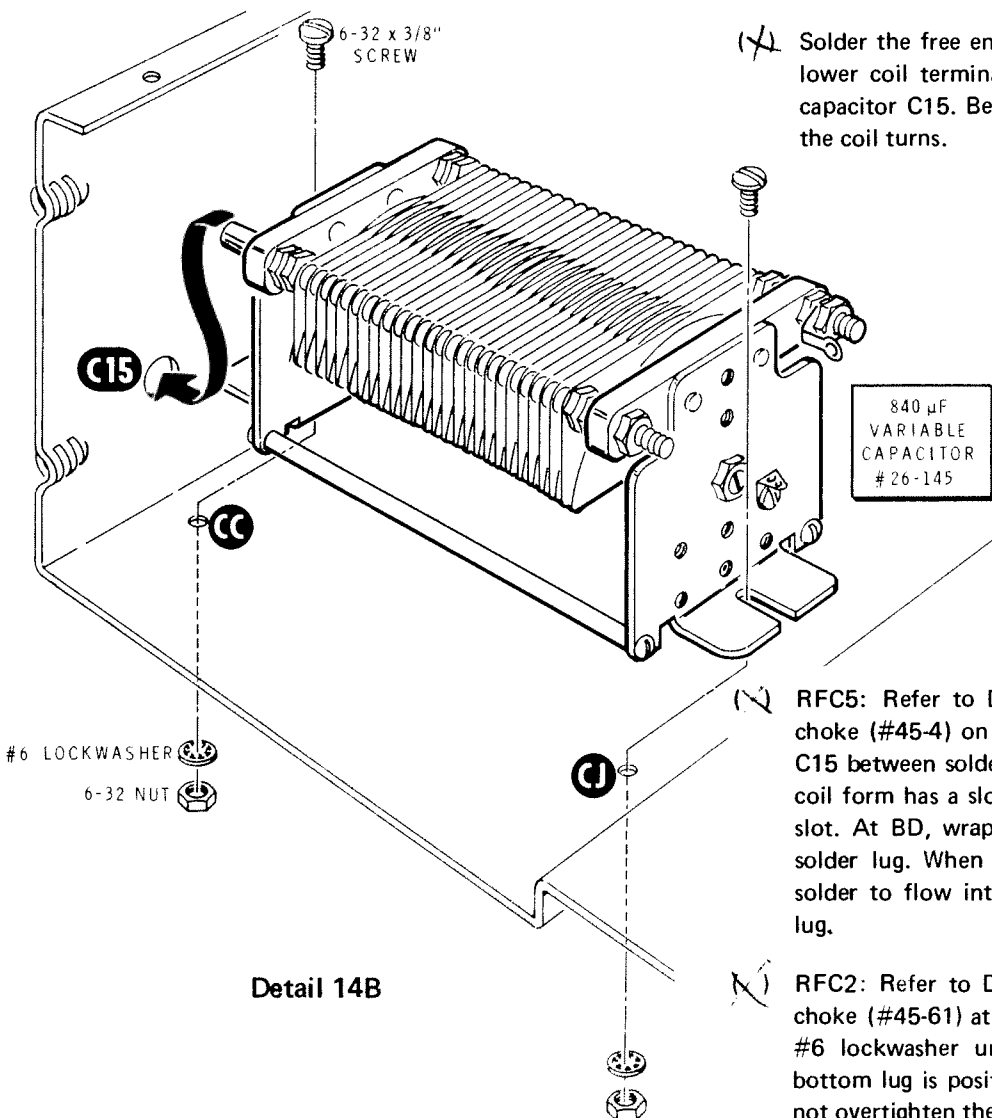

Detail 14B

5. RFC5: Refer to Detail 14C and mount 1.1 mH RF choke (#45-4) on the rear frame of variable capacitor C15 between solder lugs BC (NS) and BD (S-1). If the coil form has a slot, bend the choke leads toward the slot. At BD, wrap the lead of the choke around the solder lug. When you solder this lead, do not allow solder to flow into the hole in the end of the solder lug.

6. RFC2: Refer to Detail 14D and install a 50 μH RF choke (#45-61) at CM. Use a 6-32 x 3/8" screw with a #6 lockwasher under the screw head. Be sure the bottom lug is positioned as shown in the Pictorial. Do not overtighten the screw.



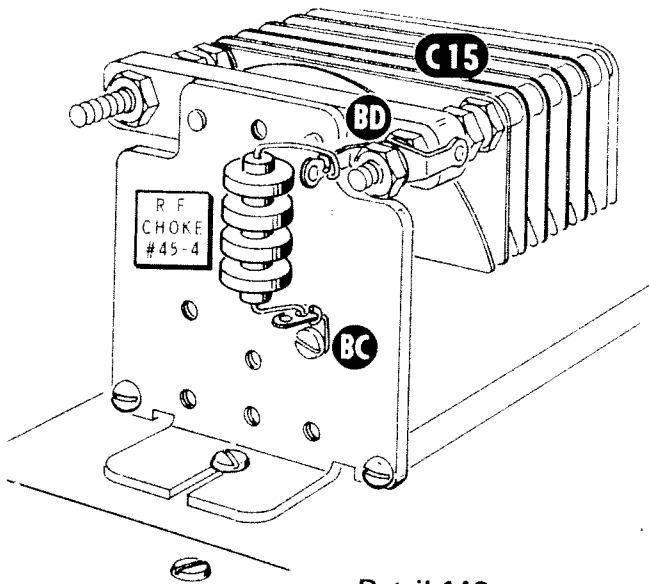

Detail 14C

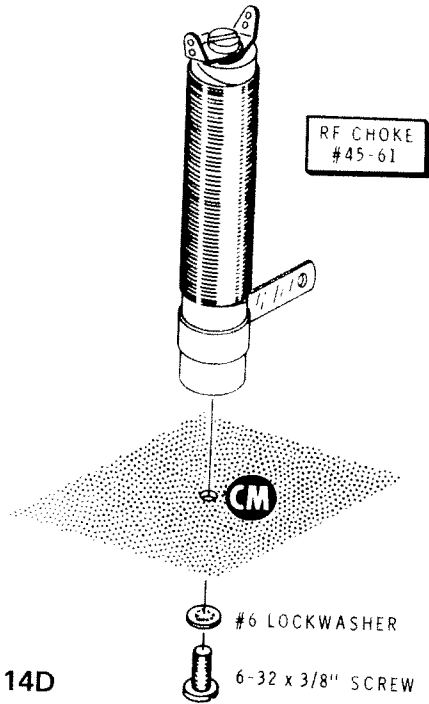

Detail 14D

C9: Cut the leads of a .001 μ F, 6 kV, disc capacitor to 1/2". Connect the capacitor from solder lug TC (S-1) to the bottom lug of RFC2 (NS).

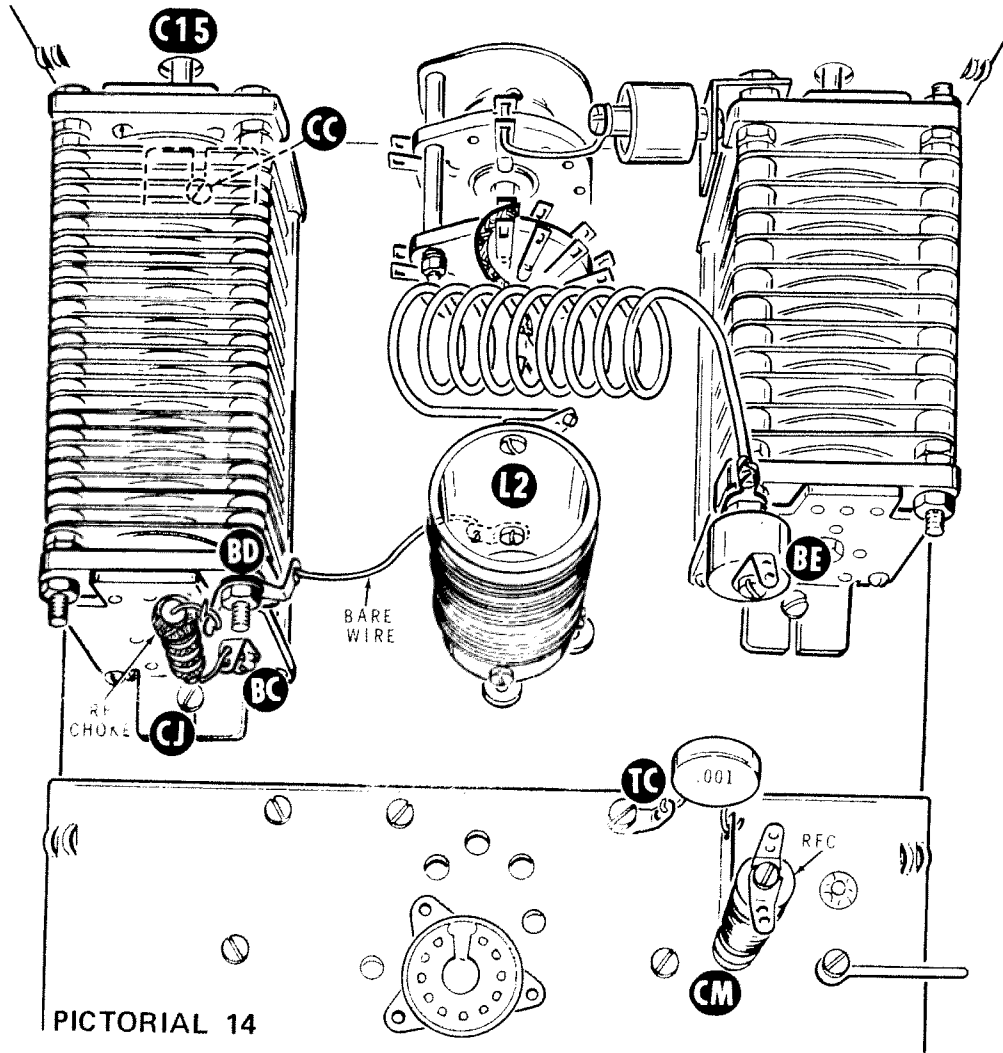

PICTORIAL 14

RF ENCLOSURE

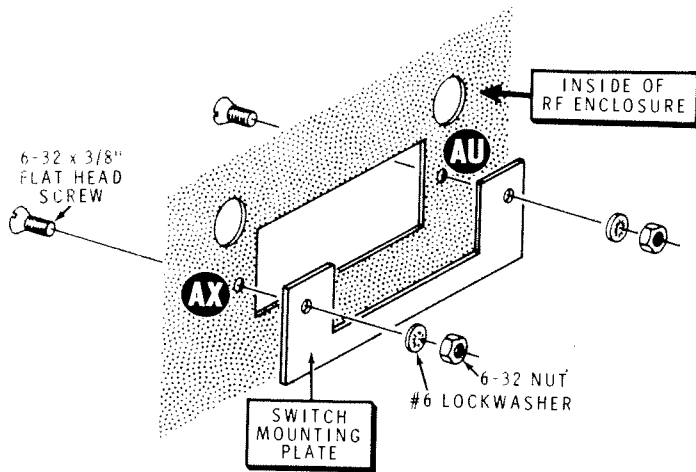

Detail 15A

SW1: Refer to Detail 15B and install the rocker switch at SW1. Be sure the words OFF and ON are positioned correctly. Then push the switch into the opening until both spring catches snap into place.

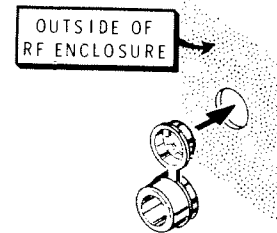

POSITION THE SMALL PORTION OF THE GROMMET INTO THE ENCLOSURE HOLE.

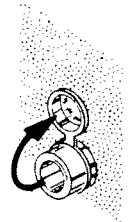

BEND THE LARGE PORTION OF THE GROMMET OVER AND INTO THE SMALL PORTION. PRESS IT FIRMLY INTO PLACE.

Refer to Pictorial 15 for the following steps.

Refer to Detail 15A and install a switch mounting plate at SW1 on the inside of the RF enclosure. Use 6-32 x 3/8" flat head screws, #6 lockwashers, and 6-32 nuts at holes AU and AX.

Detail 15C

Refer to Detail 15C and install a large plastic grommet in hole BN on the left side of the RF enclosure. Seat the grommet firmly in place.

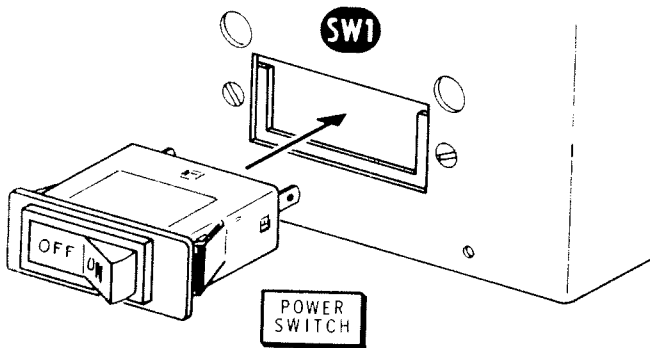

Detail 15B

Similarly, install a large plastic grommet in hole BF.

Similarly, install a small plastic grommet in hole BG on the left side of the RF enclosure.

Refer to Detail 15D (fold-out from Page 47) and attach the RF enclosure to the RF chassis. Use #6 x 1/2" hex head sheet metal screws at BJ, BL, and BM on the left side of the RF enclosure, and at holes AN, AP, and AS on the right side of the chassis.

Set the RF enclosure aside. It will be assembled later.



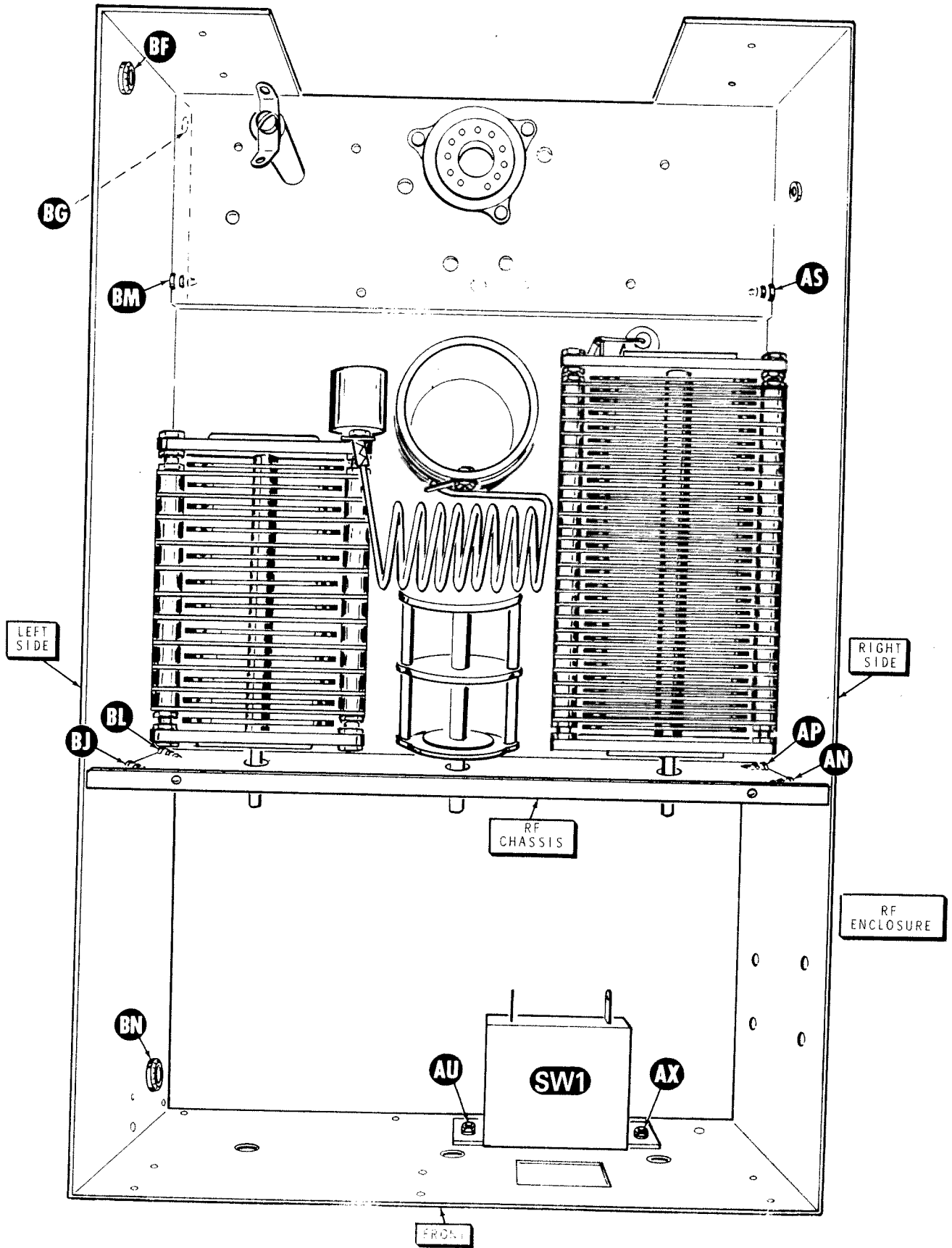

PICTORIAL 15

POWER SUPPLY CHASSIS

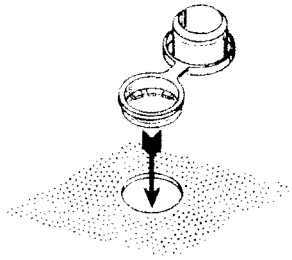

POSITION THE SMALL PORTION OF THE GROMMET INTO THE CHASSIS HOLE.

Detail 16A

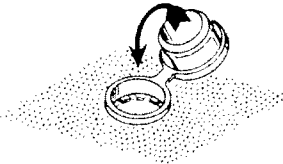

BEND THE LARGE PORTION OF THE GROMMET OVER AND INTO THE SMALL PORTION. PRESS IT FIRMLY INTO PLACE.

Refer to Pictorial 16 for the following steps.

- Refer to Detail 16A and install a large plastic grommet in hole DC on the power supply chassis.

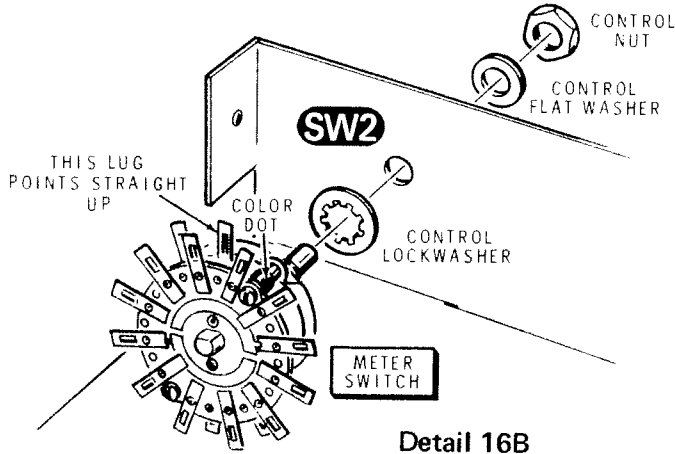

Detail 16B

- SW2: Refer to Detail 16B and mount the 1-wafer switch at SW2 on the power supply chassis. Be sure to position the color dot on the edge of the wafer as shown. All switch wiring is keyed to the position of this color dot. Use a control lockwasher, a control flat washer, and a control nut.

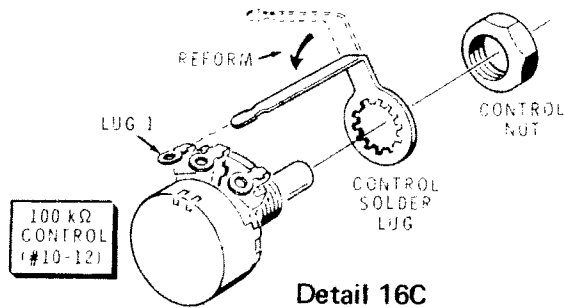

Detail 16C

- Refer to Detail 16C and place a control solder lug and a control nut on the 100 kΩ control (#10-12). Form the solder lug so it touches lug 1 of the control and solder the two lugs together. Then remove the control nut.

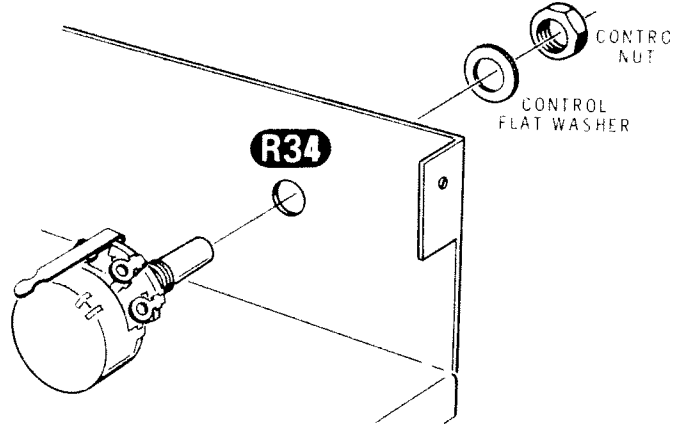

Detail 16D

- R34: Refer to Detail 16D and mount the 100 kΩ control at R34 with a control flat washer and a control nut.

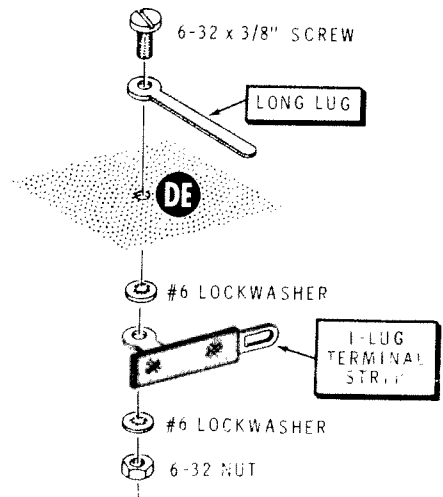

Detail 16E

- Refer to Detail 16E and install a long lug on top of the chassis and a one-lug terminal strip below the chassis at hole DE. Use 6-32 x 3/8" hardware.

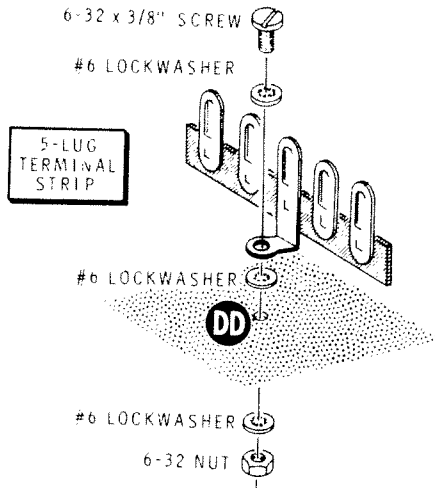

Detail 16F

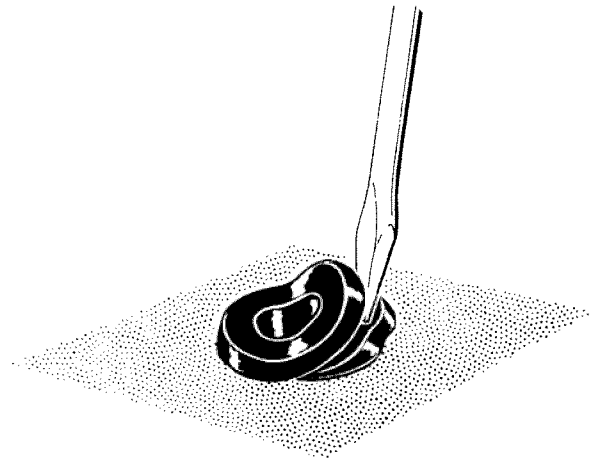

Detail 16H

- () Refer to Detail 16F and install a 5-lug terminal strip at DD. Use 6-32 x 3/8" hardware.
- () Install a large plastic grommet in hole EC.

- (X) Refer to Detail 16H and install a rubber grommet in hole DT.

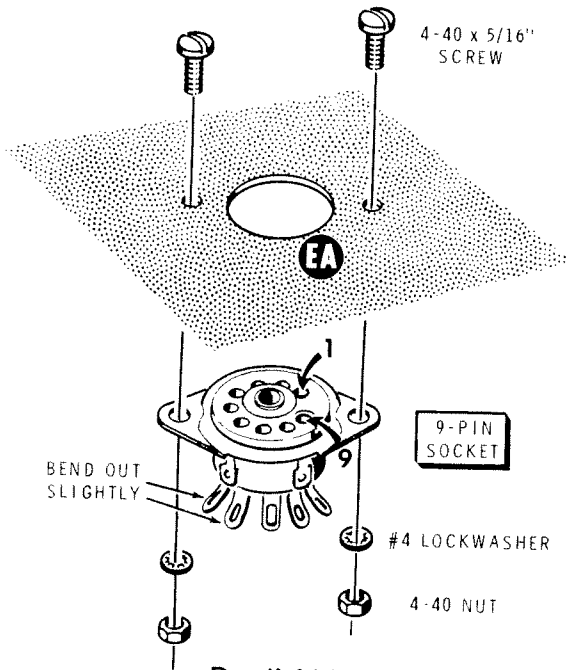

Detail 16G

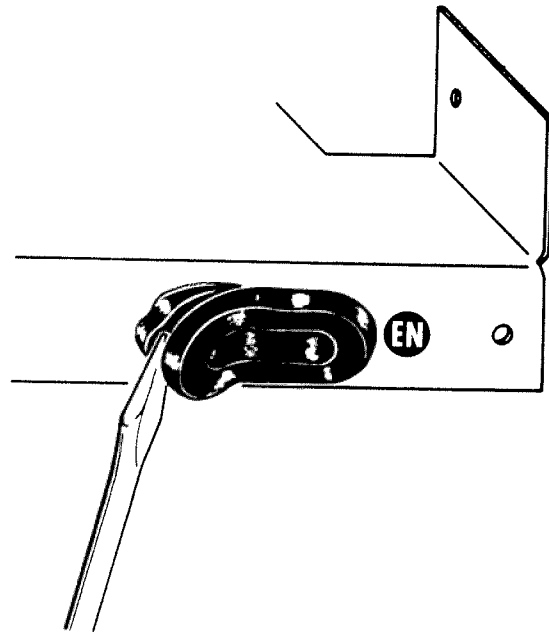

Detail 16J

- () Refer to Detail 16G and install a 9-pin socket in hole EA from the underside of the chassis. Use 4-40 x 5/16" hardware. Position the opening between the lugs 1 and 9 toward the front of the chassis.
- () Refer again to Detail 16G and bend the lugs of the 9-pin socket out slightly.

- (X) Refer to Detail 16J and install a rubber grommet on the right side of the chassis in hole EN.

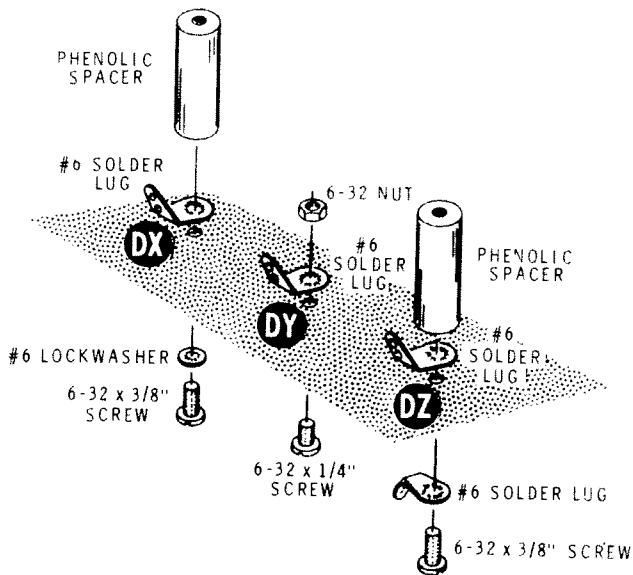

Detail 16K

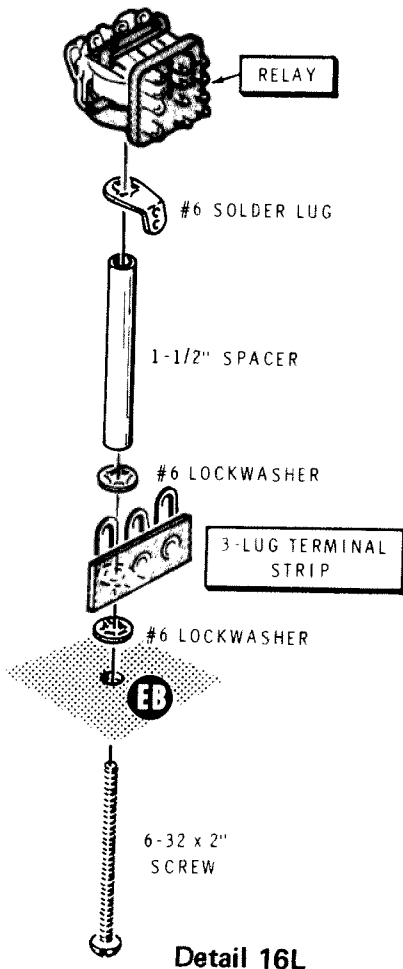

Detail 16L

Refer to Detail 16K for the next 3 steps.

CAUTION: Do not overtighten the hardware used with phenolic spacers.

- ✗ Mount a phenolic spacer at DX with a #6 solder lug. Use 6-32 x 3/8" hardware.
- ✗ Mount a phenolic spacer at DZ with #6 solder lugs above and below the chassis. Use 6-32 x 3/8" hardware.
- ✗ Install a #6 solder lug at DY. Use 6-32 x 1/4" hardware.
- ✗ RY1: Refer to Detail 16L and install a relay (#69-55) on a spacer, and a 3-lug terminal strip at hole EB. Use a 6-32 x 2" screw, a 3-lug terminal strip, a 1-1/2" spacer, a #6 solder lug and two #6 lockwashers.

CAUTION: Handle the relay carefully while you assemble the remainder of the chassis.

Refer to Pictorial 17 for the following steps.

- ✗ R1: Connect a 500 Ω , 5-watt resistor to terminal strip DD between lugs 1 (NS) and 4 (NS).
- ✗ R2: Connect a 500 Ω , 5-watt resistor to terminal strip DD between lugs 2 (NS) and 5 (NS).

NOTES:

1. The wiring of the subpanel is done before the six filter capacitors are installed. However, when you run wires to other components, keep in mind that the wires must pass around the ends of the group of six large holes so they will not interfere with the capacitors, which will be installed later.

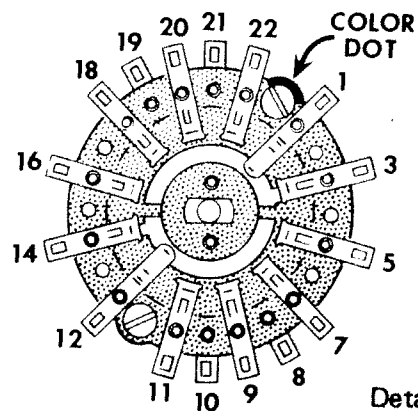

Detail 17A



2. Refer to Detail 17A for the numbering of switch SW2 solder lugs. Every hole in the switch wafer is numbered, whether a switch terminal is installed or not. Four lugs are located on the front side of the wafer (toward the subpanel.)
3. When a step calls for a two-color wire, such as "white-red," the wire will have a white body with a red stripe.
4. When you attach female connectors to wires, use a minimum amount of solder so it will not flow into the end of the connector.

(✓) Prepare the following lengths of wire. The wires are listed in the order in which they will be used.

- | | |
|----------------|------------------|
| ✓ 11" red | ✗ 21" yellow |
| ✗ 20" red | ✗ 11" yellow |
| ✗ 5" white-red | 17" white-yellow |

(✗) Solder a female connector to one end of an 11" red wire. Connect the free end of the 11" red wire to switch SW2 lug 19 (S-1).

(✗) Connect one end of a 20" red wire to switch SW2 lug 21 (S-1). Position this wire along the edge of the chassis, under control R34, and then back toward the rear of the chassis.

(✗) Connect one end of a 5" white-red wire to switch SW2 lug 12 (S-1).

(✗) Connect one end of a 21" yellow wire to switch SW2 lug 10 (S-1). Position this wire along the edge of the chassis, under control R34 and then back toward the rear of the chassis.

(✗) Solder a female connector to one end of the 11" yellow wire.

(✗) Connect the free end of the 11" yellow wire and one end of a 17" white-yellow wire to switch SW2 lug 8 (S-2). Push the other end of the 17" white-yellow wire down through grommet DC.

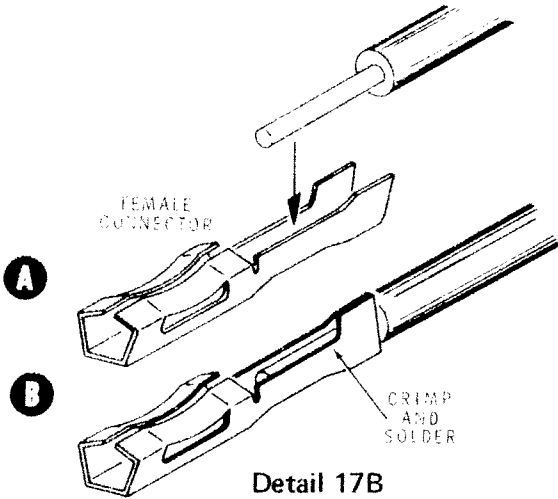

Detail 17B

(✓) Refer to Detail 17B and prepare an 11" violet wire. Solder a female connector to one end of the wire. Connect the other end to switch SW2 lug 16 (NS).

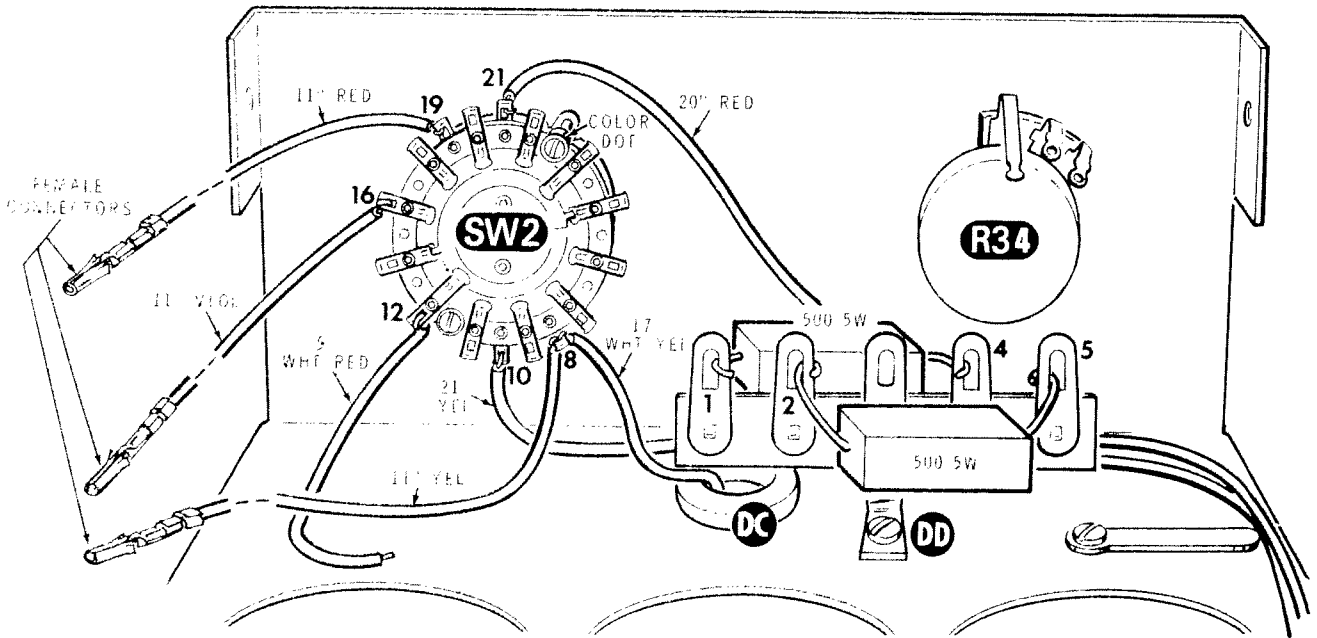

PICTORIAL 17

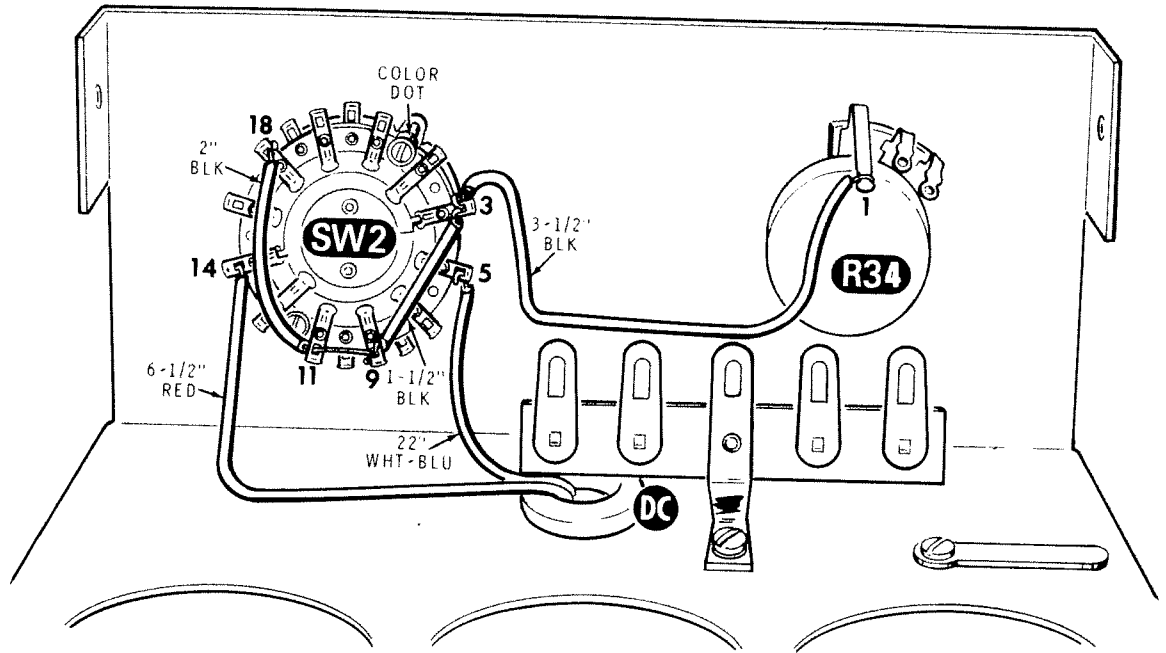

PICTORIAL 18

Refer to Pictorial 18 for the following steps.

(1) Prepare the following lengths of wire:

- ~~2"~~ black
- ~~1-1/2"~~ black
- ~~3-1/2"~~ black
- ~~22"~~ white-blue
- ~~6-1/2"~~ red

(2) Remove an additional 1/4" of insulation from one end of a 2" black wire. Push this end through switch SW2 lug 11 (S-2) to lug 9 (NS). Connect the other end of the wire to lug 18 (S-1).

(3) Connect a 1-1/2" black wire to switch SW2 between lugs 9 (S-2) and 3 (NS).

(4) Connect one end of a 3-1/2" black wire to switch SW2, lug 3 (S-2). Connect the other end to the control solder lug at lug 1 of control R34 (S-1).

(5) Connect one end of a 22" white-blue wire to switch SW2 lug 5 (S-1). Push the other end of the wire down through grommet DC.

(6) Connect one end of a 6-1/2" red wire to switch SW2 lug 14 (S-1). Push the other end of the wire down through grommet DC.

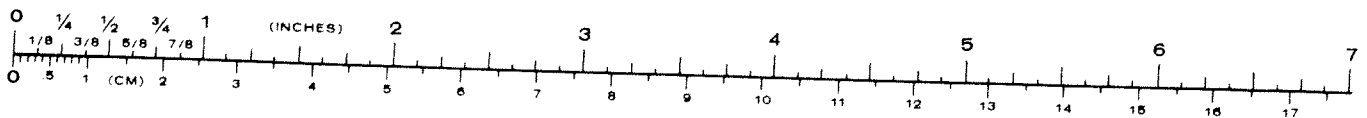

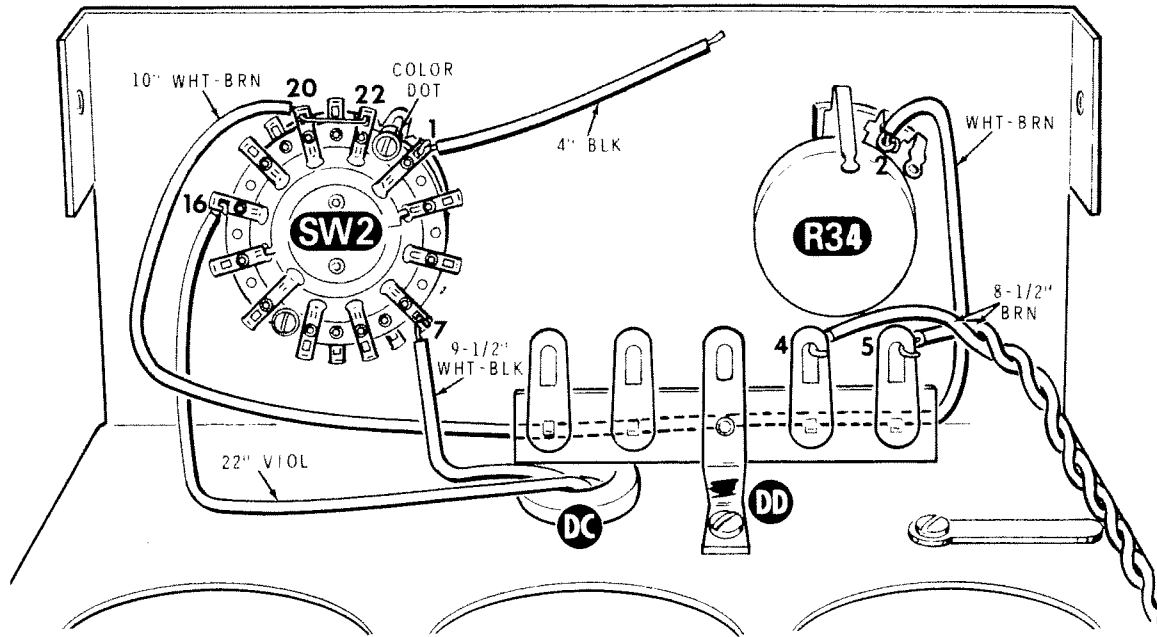

PICTORIAL 19

Refer to Pictorial 19 for the following steps.

(X) Prepare the following lengths of wire (be sure to use the small brown wire, which is tinned).

- (X) 22" violet
- 10" white-brown
- 9-1/2" white-black
- 4" black
- 8-1/2" small brown (tinned)
- 8-1/2" small brown (tinned)

(X) Connect one end of a 22" violet wire to switch SW2 lug 16 (S-2). Push the other end of this wire down through grommet DC.

(X) Remove an additional 1/4" of insulation from one end of a 10" white-brown wire. Push this end through switch SW2 lug 20 (S-2) to lug 22 (S-1). Connect the other end of this wire to control R34 lug 2 (S-1).

(X) Connect one end of a 9-1/2" white-black wire to switch SW2 lug 7 (S-1). Push the other end of the wire down through grommet DC.

(X) Connect one end of a 4" black wire to switch SW2 lug 1 (S-1).

(X) Refer to Detail 19A and form a "twisted pair" with the two 8-1/2" brown wires. Connect one end of the twisted pair to terminal strip DD: one wire to lug 4 (S-2) and the other wire to lug 5 (S-2).

TWISTED PAIR



Detail 19A

Refer to Pictorial 20A (fold-out from Page 48) for the following steps.

- (X) R35: Connect a 1000 Ω (brown-black-red) resistor to terminal strip EB between the lower holes of lugs 1 (S-1) and 2 (S-1).
- (X) C21: Connect a .02 μ F disc capacitor to terminal strip EB between lugs 2 (NS) and 3 (NS).
- (X) D18: Connect the lead at the banded end of a 1N191 diode (#56-26, brown-white-brown) to terminal strip EB lug 3 (NS); and connect the other lead to lug 1 (NS).
- (X) Prepare a 15" white-brown wire. Connect one end to terminal strip EB lug 3 (S-3) and the other end to control R34 lug 3 (S-1).
- (X) Prepare a 6-1/2" black wire and solder a female connector to one end. Connect the other end to terminal strip EB lug 2 (S-2).

NOTE: Refer to the inset #1 drawing of Pictorial 20 for lug numbering of RY1. Refer to inset drawing #2 for the detail of wiring terminal strip EB.

- (X) R36: Cut one of the leads of a 27 k Ω , 1-watt (red-violet-orange) resistor to 1" and the other lead to 3/4". Place a 3/4" length of small black sleeving on the 1" lead and connect the lead to lug 7 of relay RY1 (NS). Connect the other resistor lead to terminal strip EB lug 1 (S-2). Provide at least 1/8" clearance between the resistor lead and relay lug #9.

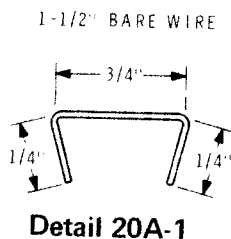

- (X) Refer to Detail 20A-1 and form a 1-1/2" length of bare wire so it will fit between lugs 1 and 3 of relay RY1. Solder the wire to each lug. Cut off any excess wire which protrudes down toward the relay lugs immediately below.

() Prepare the following lengths of wire:

- X 9" white
- X 13" white
- X 5-1/2" large brown (stranded)

- (X) Solder a female connector to one end of a 9" white wire.
- (X) Connect the other end of the wire to relay RY1 lug 11 (NS).
- (X) Connect the red wire coming from switch SW2 to relay RY1 lug 11 (NS).
- (X) Connect one end of a 13" white wire to relay RY1 lug 12 (NS). Push the other end of this wire down through grommet EC.
- (X) Connect one end of a 5-1/2" large brown (stranded) wire to the solder lug under the spacer at DX (NS).

Refer to Pictorial 20B (fold-out from Page 48) for the following two steps.

- (X) D17: Refer to Detail 20B and place a 1" length of small black sleeving on each lead of a 1N2071 diode (#57-27). Connect the lead at the banded end of the diode to lug 12 of relay RY1 (NS). Position the diode back of the relay and connect the other lead to lug 11 (NS).
- (X) R23: Place a 1-1/4" length of small black sleeving on each lead of a 1500 Ω , 10-watt resistor. Position the resistor above relay RY1 and connect it to relay lugs 12 (NS) and 11 (S-4).

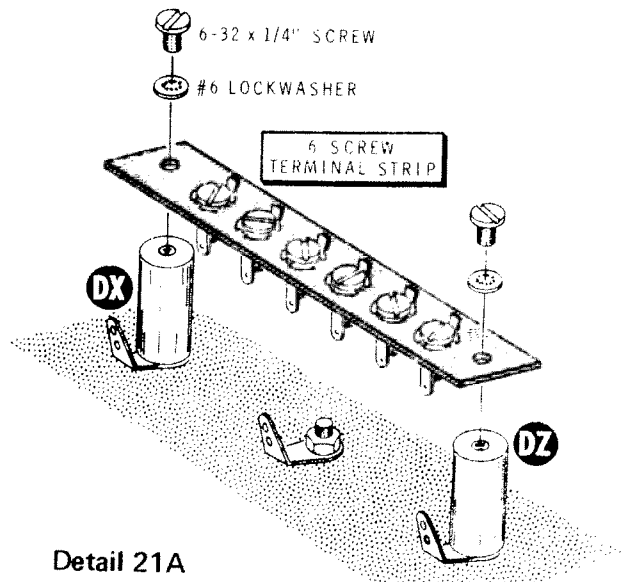

Refer to Pictorial 21 for the following steps.

- ✗ Refer to Detail 21A and install a 6-screw terminal strip on the two phenolic spacers. Use 6-32 x 1/4" screw and #6 lockwashers.
- ✗ Cut a 20-1/2" and a 19" large brown (stranded) wire. DO NOT remove any insulation yet. Insert these wires into a 16" length of large black sleeving. Then remove 1/4" of insulation from the ends of each wire and melt a minimum amount of solder on the small strands at the wire ends.

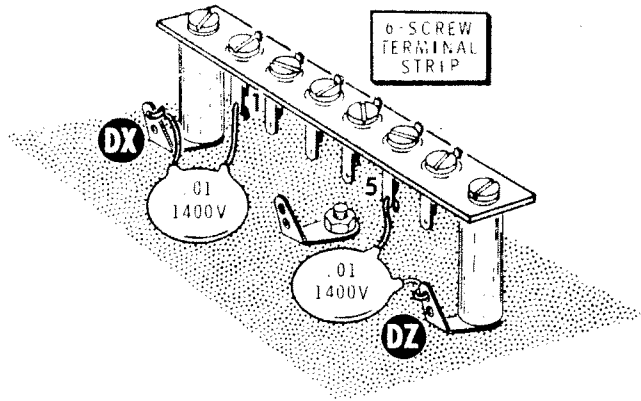

Detail 21C

Refer to Detail 21C for the following two steps.

- ✗ C1: Connect a .01 μ F, 1400 volt disc capacitor (#21-70) between 6-screw terminal strip lug 1 (S-2) and solder lug DX (S-2).
- ✗ C2: Connect a .01 μ F, 1400 volt disc capacitor between 6-screw terminal strip lug 5 (NS) and solder lug DZ (S-1).

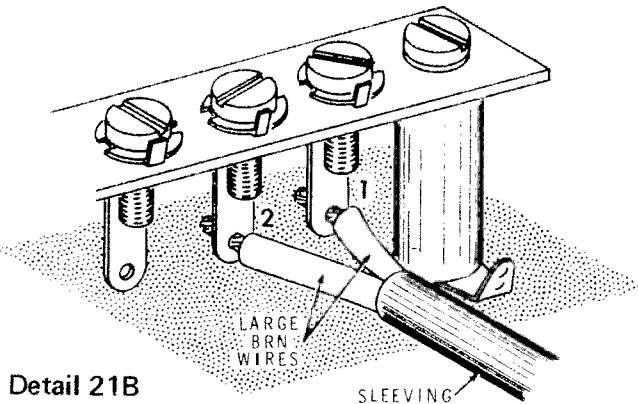

Detail 21B

- ✗ Refer to Detail 21B and connect one end of the pair of large brown (stranded) wires to 6-screw terminal strip lugs 1 (NS) and 2 (NS).
- ✗ Prepare a 17" and a 16" small brown (tinned) wire and form a twisted pair (approximately one turn in two inches). Connect one end of the twisted pair to terminal strip DD lugs 1 (S-2) and 2 (S-2). Connect the other end of the twisted pair to 6-screw terminal strip lugs 2 (S-2) and 4 (NS).

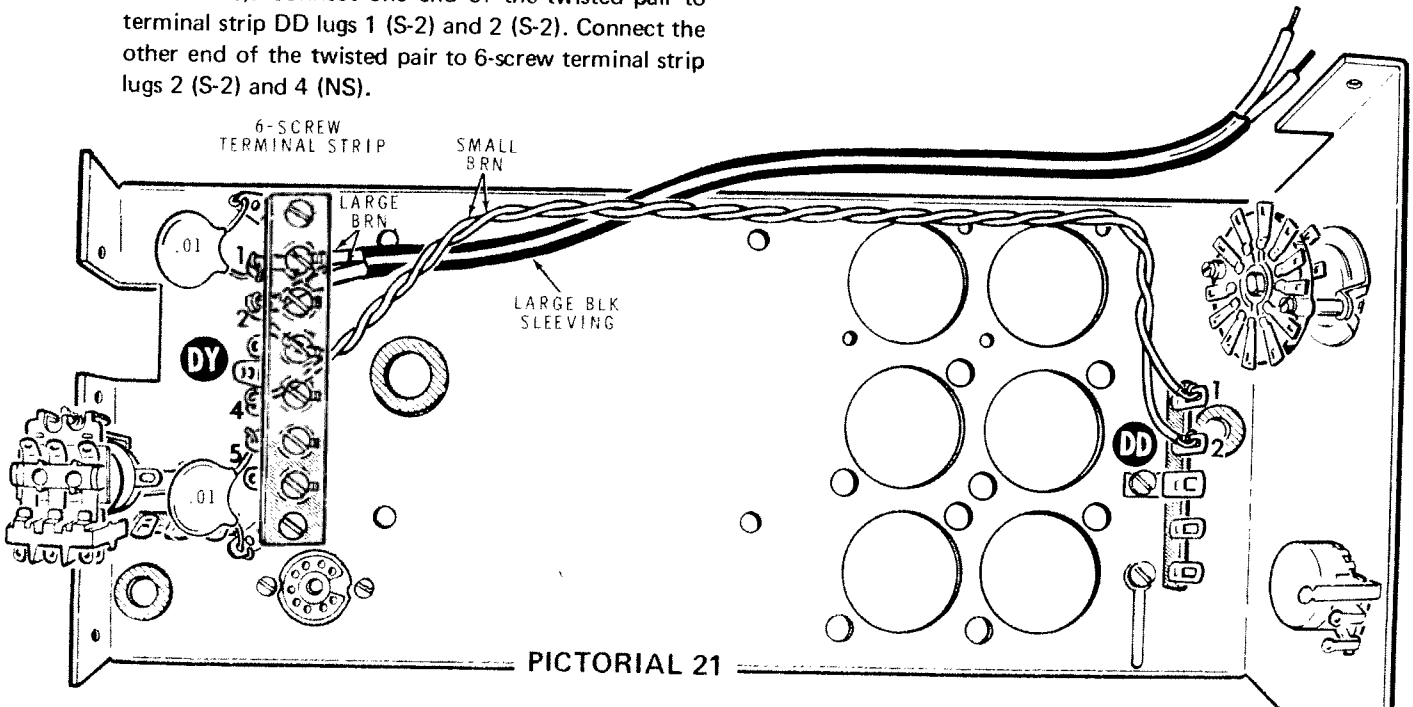

PICTORIAL 21

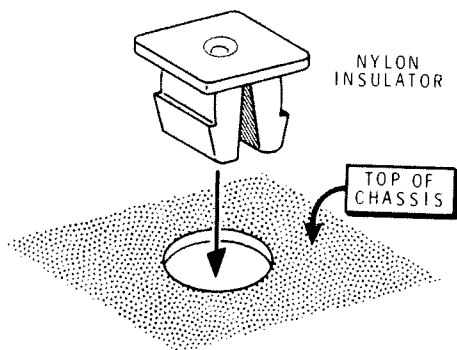

Detail 22A

Refer to Pictorial 22 (fold-out from Page 59) for the following steps.

✗ Refer to Detail 22A and, from the top of the chassis, press eight nylon insulators into the holes in the power supply chassis at DF, DG, DH, DJ, DK, DL, DM, and DN. Push the insulators down against the chassis as far as they will go.

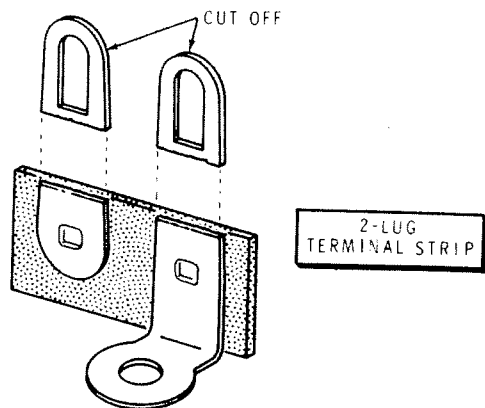

Detail 22C

✗ Refer to Detail 22C and cut off the lugs of a 2-lug terminal strip as shown.

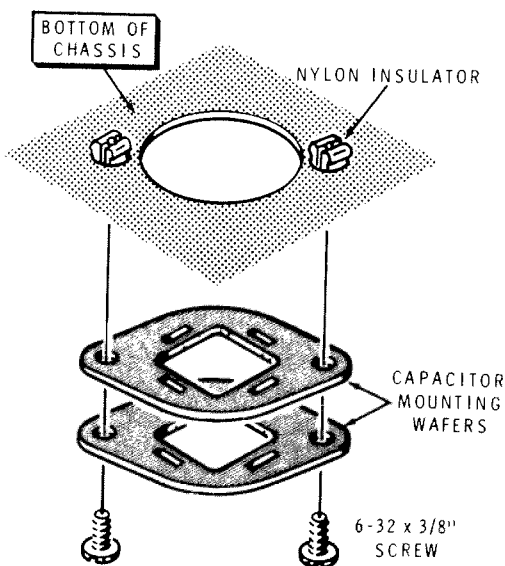

Detail 22B

✗ Refer to Detail 22B and, on the top of the chassis, install two capacitor mounting wafers at each of holes C3, C4, C5, and C6. Use 6-32 x 3/8" screws. Turn the screws into the nylon insulators.

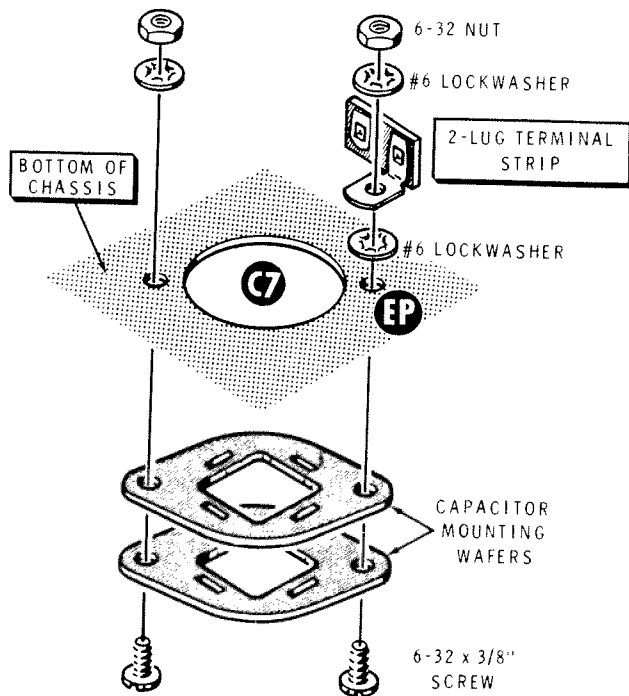

Detail 22D

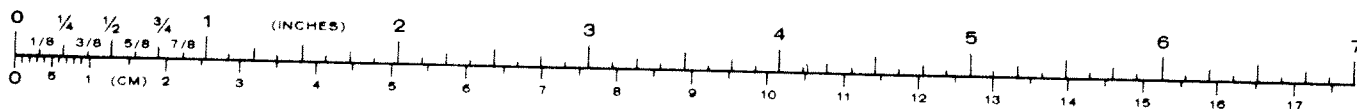

Refer to Detail 22D and install two capacitor mounting wafers at C7. Mount the 2-lug terminal strip under the chassis at EP. Use 6-32 x 3/8" screws, #6 lockwashers, and 6-32 nuts.

Install two capacitor mounting wafers at hole C8. Use 6-32 x 3/8" screws, #6 lockwashers, and 6-32 nuts.

CAUTION: The filter capacitors in the high voltage circuit will be wired next. To avoid difficulty later, be sure to review each step a second time to make sure there are no wiring errors.

C3, C4, C5, C6, C7, C8: Refer to Detail 22E and install six 125 μ F electrolytic capacitors in the six mounting locations. Be sure to position the positive lug of each capacitor as shown in Detail 22F. Note carefully for each capacitor which lugs are twisted to hold the capacitor to the wafer. Use pliers to twist each lug about one-eighth turn.

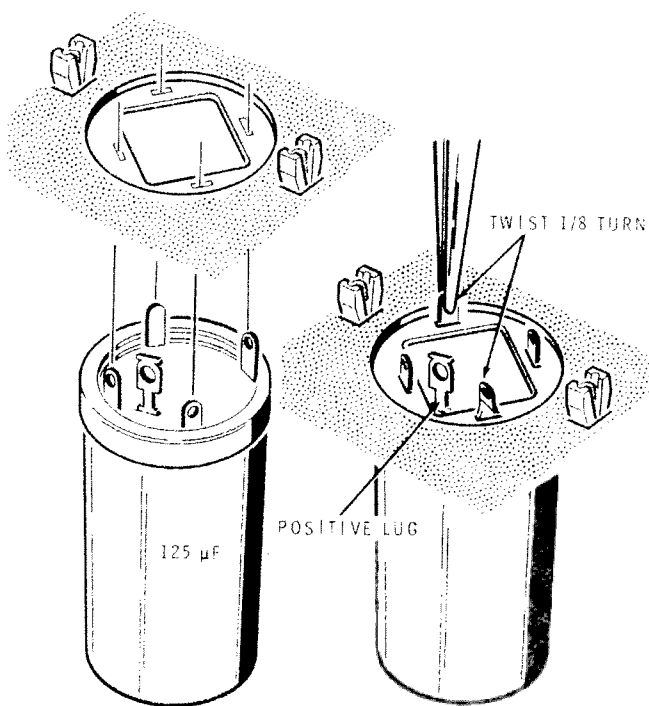

Detail 22E

R3, R4, R5, R6, R7, R8: Refer to Detail 22F and install a 100 k Ω , 2-watt (brown-black-yellow) resistor on the bottom of each filter capacitor. Solder the six

connections marked "solder" in the Detail. Bend the longer lead as closely as possible to the body of the resistor to provide as much clearance as possible from the negative capacitor lug. Position the resistor in the square wafer opening.

() Prepare the following lengths of large blue wire:

- 1-1/2"
- 3-1/4"
- 1-1/2"
- 3"
- 1-1/2"

Connect these large blue wires between capacitors as follows:

- 1-1/2" from C3 (S-1) to C4 (S-2).
- 3-1/4" from C4 (S-1) to C5 (S-2).
- 1-1/2" from C5 (S-1) to C6 (NS).
- 3" from C6 (S-1) to C7 (S-2).
- 1-1/2" from C7 (S-1) to C8 (S-2).

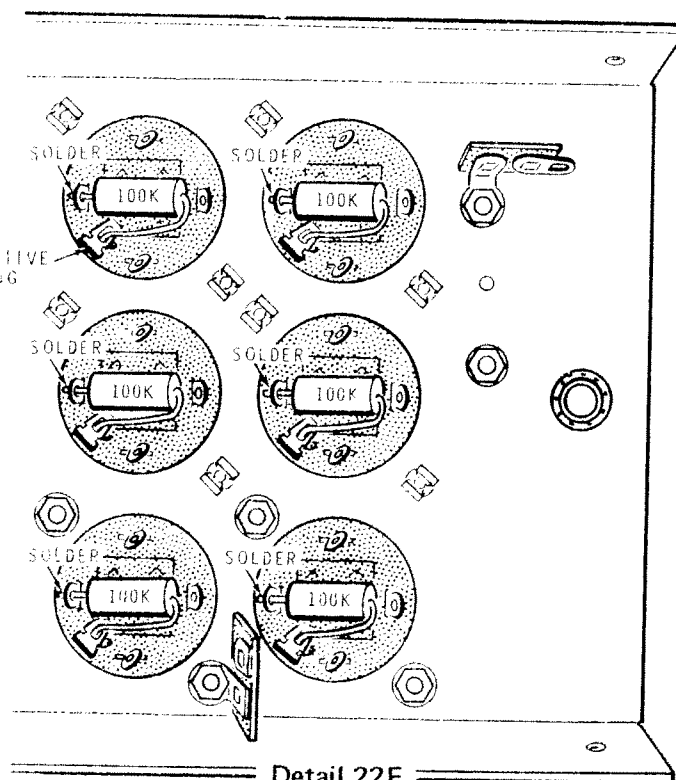

Detail 22F

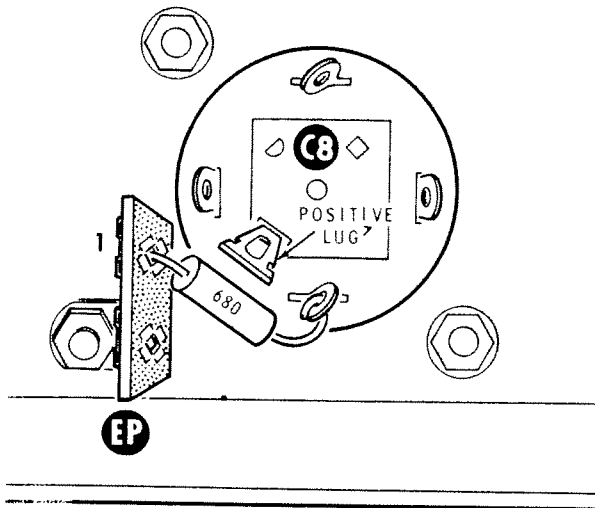

Detail 22G

- (X) R11: Refer to Detail 22G and connect a 680 Ω (blue-gray-brown-gold) resistor from terminal strip EP, the lower hole of lug 1 (NS), to a mounting lug of C8 (S-1). Provide clearance as shown between this resistor and the positive lug of C8.
- (X) Connect the white-black wire coming from grommet DC to terminal strip EP, the lower hole of lug 1 (S-2).
- (X) R9: Cut one lead of a 1 Ω , 5-watt, 1% resistor to 1-1/4". Place a 1" length of small black sleeving on this lead and connect the lead to C8 lug ER (NS). Connect the other lead to terminal strip EP, the lower hole of lug 2 (S-1).
- (X) Prepare a 15" length of white-black wire and solder a female connector to one end. From the top of the chassis, push the other end of the wire down through grommet DC and connect it to C8 lug ER (S-2).
- (X) Start with the step for mounting the six filter capacitors and Detail 22F, and check every connection for accuracy and for compliance with the solder instructions. Check the position of the positive lug of each capacitor.
- (X) Connect the red wire coming from grommet DC to terminal strip DE lug 1 (NS).
- (X) Remove another 1/4" of insulation from the white-yellow wire coming from grommet DC. Connect this wire to socket EA, through lug 9 (S-2) to lug 8 (S-1).
- (X) Prepare a 26" white-red wire and solder a female connector to one end. From the top of the chassis, push the free end down through grommet DC.
- (X) At the free end of the white-red wire, remove an additional 1/4" of insulation. Connect this end of the wire to socket EA, through lug 4 (S-2) to lug 3 (NS).
- (X) Prepare a 17" black wire. Connect one end of this wire to socket EA, lug 3 (S-2). Push the other end of this wire up through grommet EC.

ASSEMBLED CHASSIS

Refer to Pictorial 23 for the following steps.

- (X) Place the power supply chassis alongside the RF enclosure as shown. As you position the power supply chassis, start the two brown wires in the black sleeving and the four wires with the female connectors (red, yellow, violet, and white-red) through grommet BN into the RF enclosure. Check for any wires which might be pinched between the chassis and enclosure. Then fasten the two assemblies together with 6-32 x 3/8" screws, #6 lockwashers, and 6-32 nuts at holes BH, BK, and BP. At hole BR, use 6-32 x 3/8" hardware and a #8 long lug.



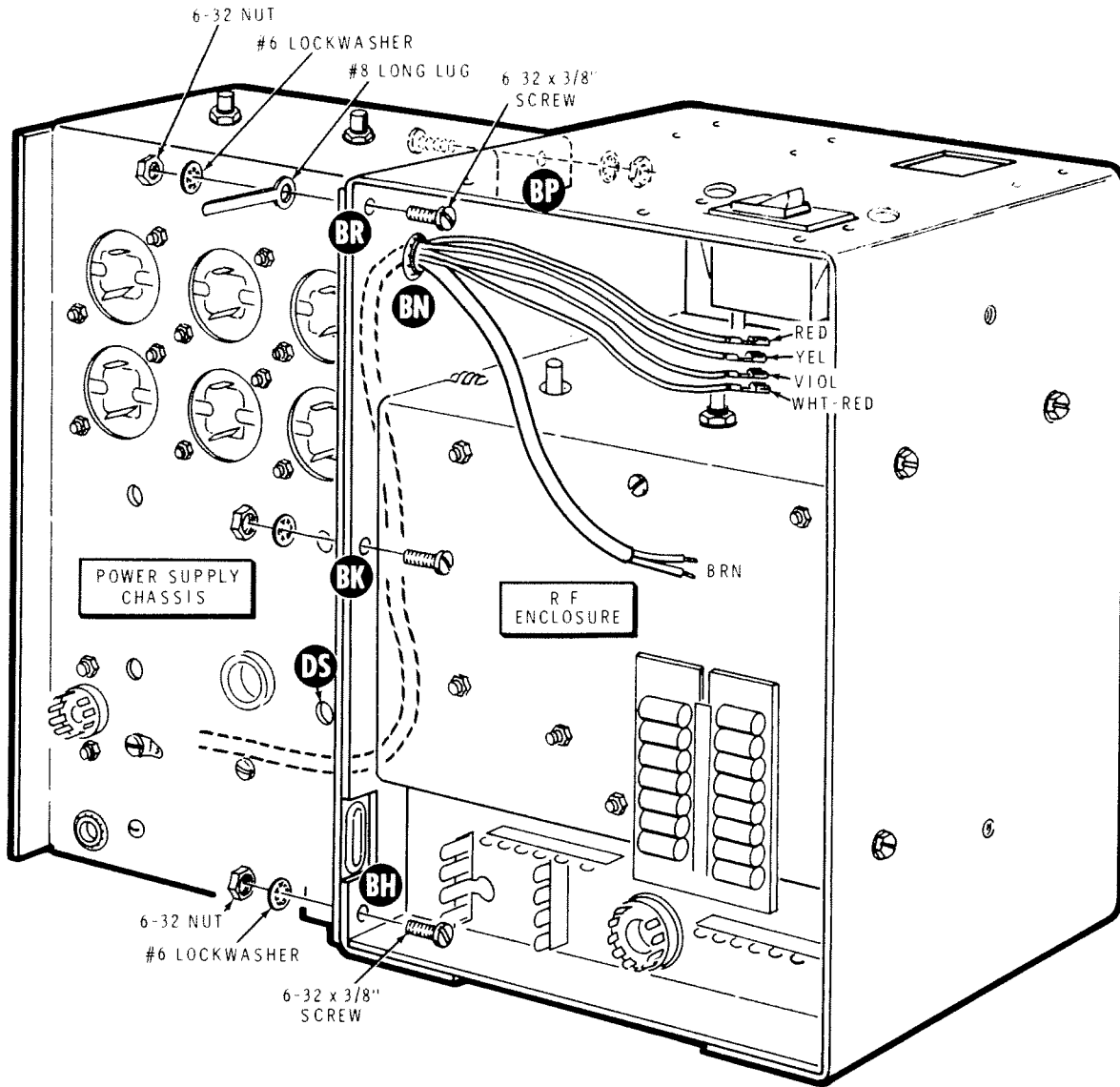

PICTORIAL 23

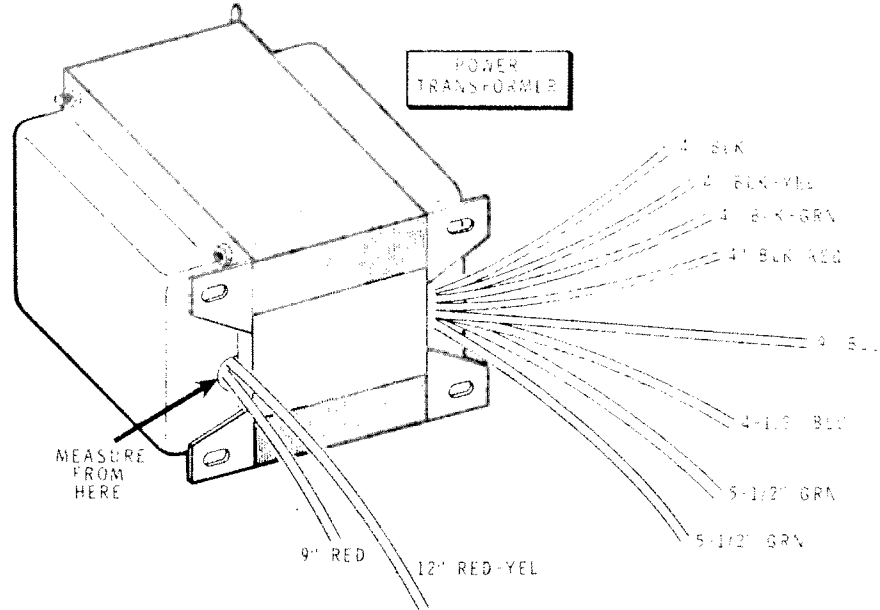

Detail 24A

Refer to Pictorial 24 (fold-out from this page) for the following steps.

X Refer to Detail 24A and cut the leads of the power transformer to the following lengths. Measure all leads from where they exit from the end bells. After cutting the leads, remove 1/4" of insulation from the end of each lead. If the stranded leads are not solder coated, twist the fine strands together and melt a minimum amount of solder on each to prevent the strands from "straying" and possibly causing a short circuit.

Lead Color	Cut To:
Red	9"
Red/yellow	12"
Black	4"
Black/yellow	4"
Black/green	4"
Black/red	4"
One blue	9"
Other blue	4-1/2"
Both green	5-1/2"

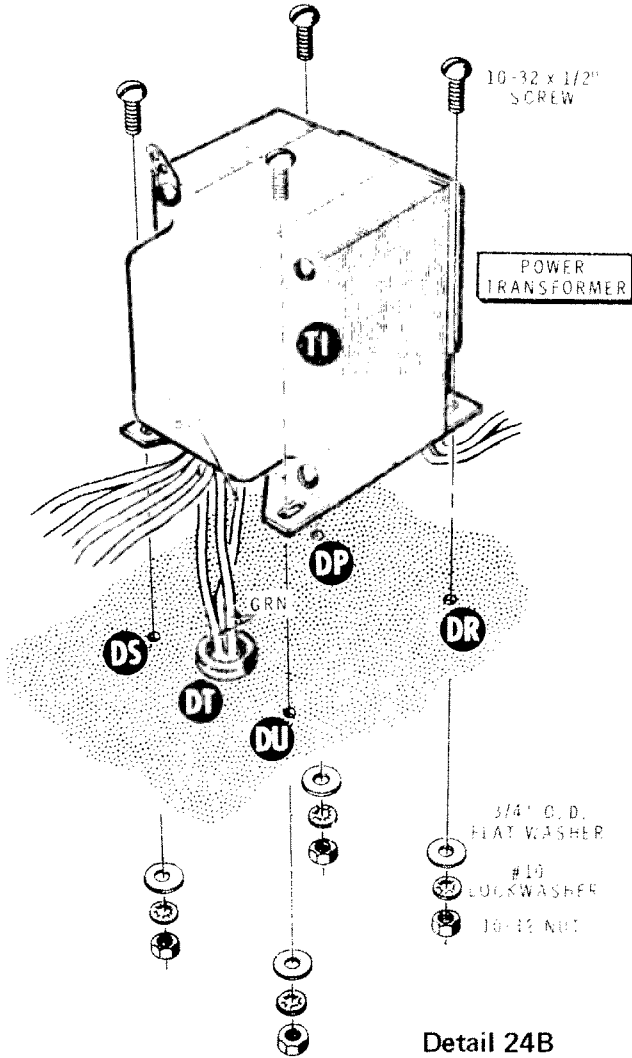

Detail 24B

X T1: Refer to Detail 24B and mount the power transformer at holes DP, DR, DS, and DU. At each hole, use a 10-32 x 1/2" screw, a 3/4" O.D. flat washer, a #10 lockwasher, and a 10-32 nut. As you lower the transformer into place, insert both green

leads and the 4-1/2" blue lead down through grommet DT. NOTE: Insertion of the screws into holes DP and DS may be easier if you will refer to the inset drawing on the Pictorial and use the 7" length of clear sleeving as an aid for placing the screws. Save the sleeving for use later.

- ~~X~~ Check to make sure there are no transformer leads or other wires pinched under the transformer.
- () Solder a female connector to the end of the red transformer lead.
- (X) Solder a female connector to the end of the 9" blue transformer lead.
- ~~X~~ Bring the red/yellow lead around the end of the filter capacitors and push it down through grommet DC.

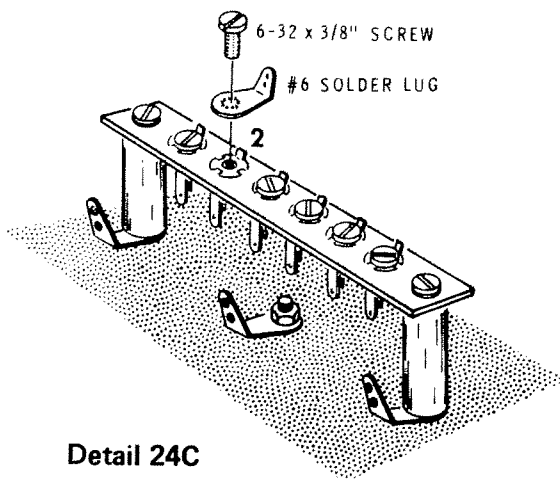

Detail 24C

- ~~X~~ Remove and discard the screw from lug 2 of the 6-screw terminal strip. Refer to Detail 24C and replace this screw with a #6 solder lug and a 6-32 x 3/8" screw. Turn the screw only halfway in.
- ~~X~~ Point the solder lug toward the transformer and solder the #6 solder lug to the terminal strip metal on the top of the terminal strip insulator. Try to keep the solder away from the screw threads (the screw is present during the soldering to maintain the correct alignment of the solder lug with the screw threads).

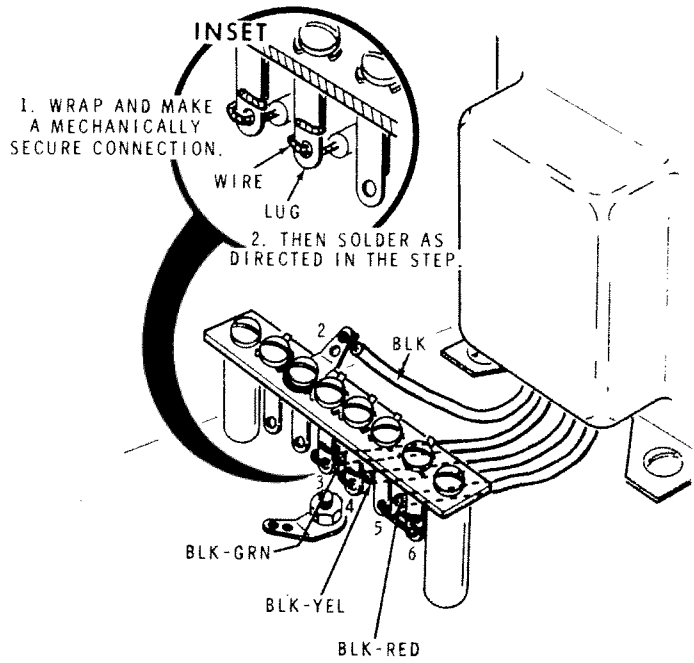

Detail 24D

Refer to Detail 24D and connect transformer primary leads to the solder lugs of the 6-screw terminal strip as follows. Make sure each connection is mechanically secure before you solder it. To make a mechanically secure connection, insert the wire through or wrap it around the lug or terminal, or both, before soldering. See the inset drawing.

- ~~X~~ Remove an additional 1/2" of insulation from the black/red lead. Push this lead through lug 5 (S-3) to lug 6 (S-1).
- ~~X~~ Connect the black/yellow lead to lug 4 (S-2).
- ~~X~~ Connect the black/green lead to lug 3 (S-1).
- ~~X~~ Connect the black lead to the solder lug which was added to screw 2 (S-1).
- ~~X~~ Refer to Pictorial 24 and connect the brown wire coming from the solder lug under spacer DX to the solder lug on the transformer core bolt (S-1).

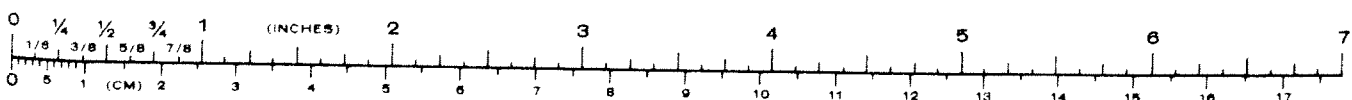

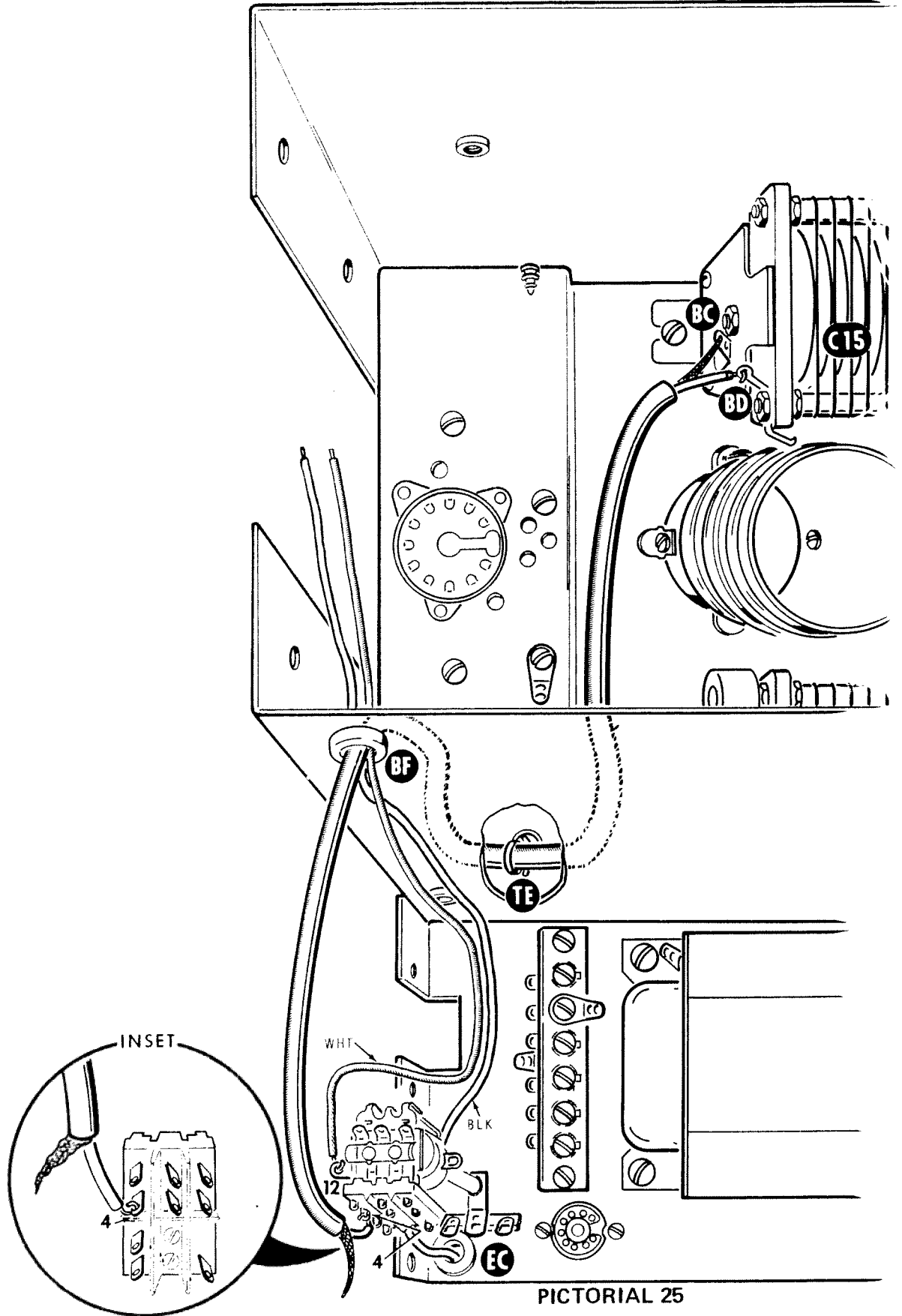

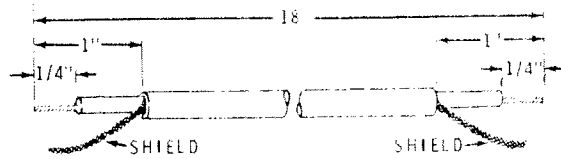

REMOVE THE OUTER INSULATION

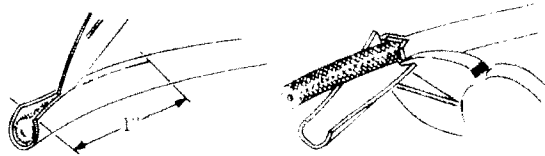

PUSH BACK THE SHIELD. THEN MAKE AN OPENING IN THE SHIELD AND BEND OVER AS SHOWN. PICK OUT THE INNER LEAD.

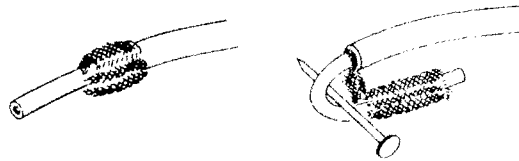

REMOVE THE INNER INSULATION AND STRETCH OUT THE SHIELD. APPLY A SMALL AMOUNT OF SOLDER TO THE END OF THE SHIELD AND INNER LEAD. USE ONLY ENOUGH HEAT FOR THE SOLDER TO FLOW.

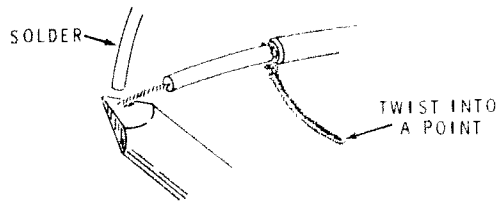

Detail 25A

Refer to Pictorial 25 for the following steps.

- (X) Prepare a 16" white wire. Connect one end of this wire to relay lug 12 (S-4). Position this wire down against the chassis and push the other end through grommet BF into the RF enclosure.
- (X) Route the black wire (coming from grommet EC) under the relay, along the white wire, and through grommet BF as in the previous step.
- (X) Refer to Detail 25A and prepare an 18" coaxial cable.

- (N) At one end of the coaxial cable, connect the inner conductor to relay lug 4 (S-1). The shield wires will be connected later.
- (X) Push the other end of the coaxial cable through grommet BF into the RF enclosure. Bend the cable down and secure it by wrapping lug TE around the body of the cable. Then connect the inner conductor to loading capacitor C15 at solder lug BD. Use the lug to which the RF choke was soldered (S-1). Connect the shield wires to the solder lug at BC (S-2).



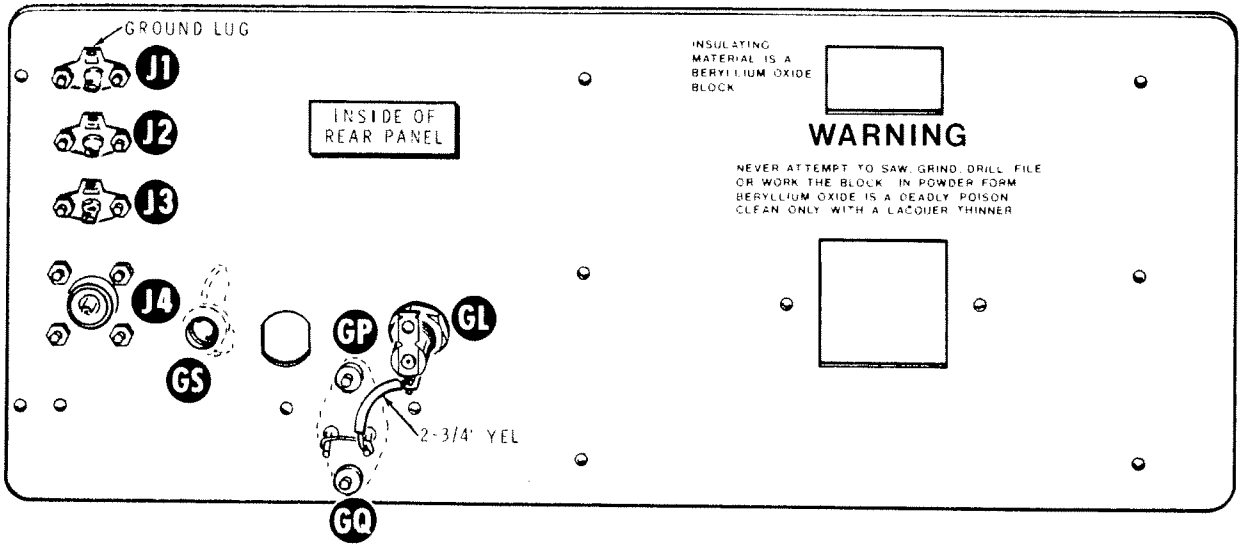

PICTORIAL 26

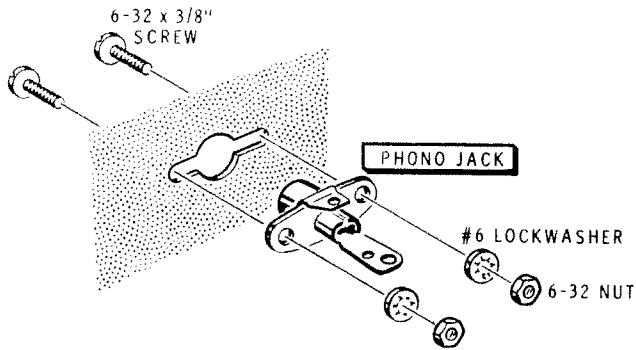

Detail 26A

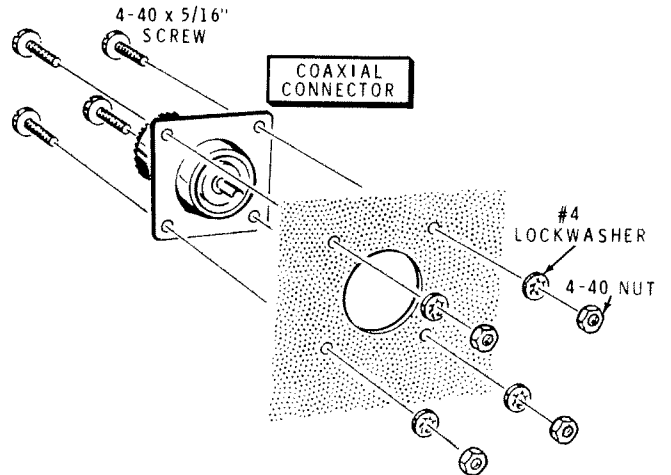

Detail 26B

Refer to Pictorial 26 for the following steps.

~~J1, J2, J3:~~ Refer to Detail 26A and install phono jacks at J1, J2, and J3 on the rear panel. Use 6-32 x 3/8" hardware at each mounting hole. Position the ground lug as shown.

~~J4:~~ Refer to Detail 26B and install a coaxial connector at J4 on the rear panel. Use 4-40 x 5/16" hardware.

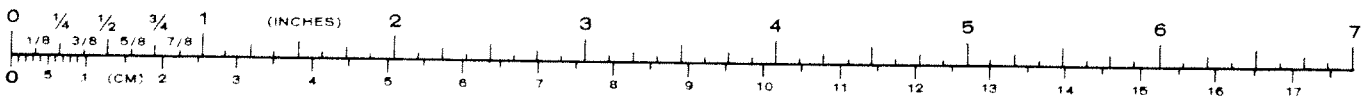

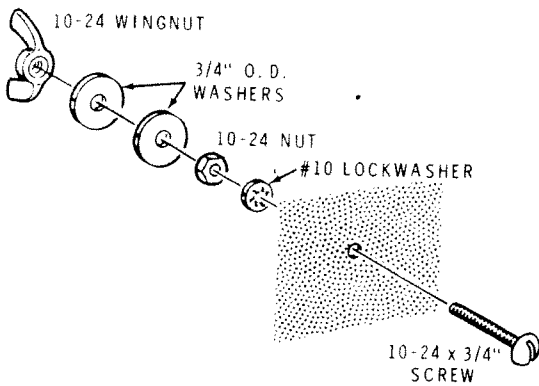

Detail 26C

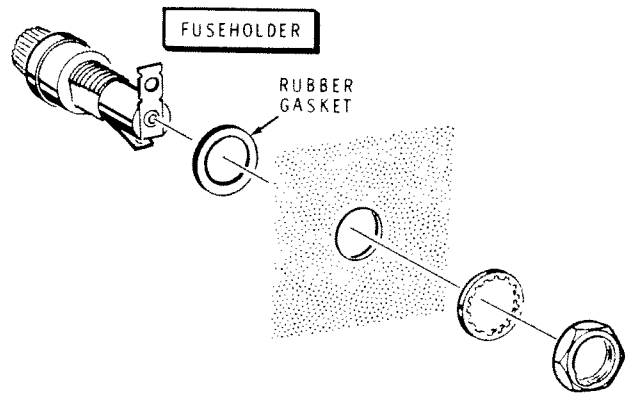

Detail 26E

- () Refer to Detail 26C and install a 10-24 x 3/4" screw, a #10 lockwasher, a 10-24 nut, two 3/4" O.D. flat washers, and a 10-24 wingnut at GS on the rear panel.

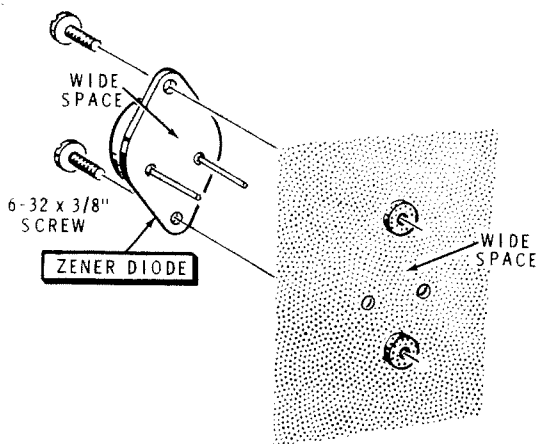

Detail 26D

- (X) Prepare a 2-3/4" yellow wire. Connect one end of this wire to the solder lug on the side of the fuseholder (S-1).
- (X) Remove an additional 1" of insulation from the free end of the yellow wire.
- (X) Connect the free end of this yellow wire to zener diode ZD1. Wrap the yellow wire around either diode pin (S-2) and then connect the wire to the remaining pin (S-1).

- (X) ZD1: Refer to Detail 26D and install a 1N2806A zener diode (#56-609) on the rear panel. Use 6-32 x 3/8" screws at GP and GQ.

- (X) Refer to Detail 26E and install the fuseholder at GL on the rear panel using the rubber gasket and the hardware supplied with the holder.

- (X) F1: Install the 3/4 ampere, slow-blow fuse in the fuseholder.

WARNING:

The thermal compound used in the following step (and later when mounting the amplifier tube) can be injurious to both your eyes and your clothes. It should be handled with utmost care.

KEEP THE COMPOUND AWAY FROM YOUR EYES. Wash your hands immediately after using the compound. Should you get any in your eyes, wash them out with water at once and get to a doctor as soon as possible.

KEEP THE COMPOUND OFF YOUR CLOTHES. If you get the compound on your clothes it may leave a permanent white stain.

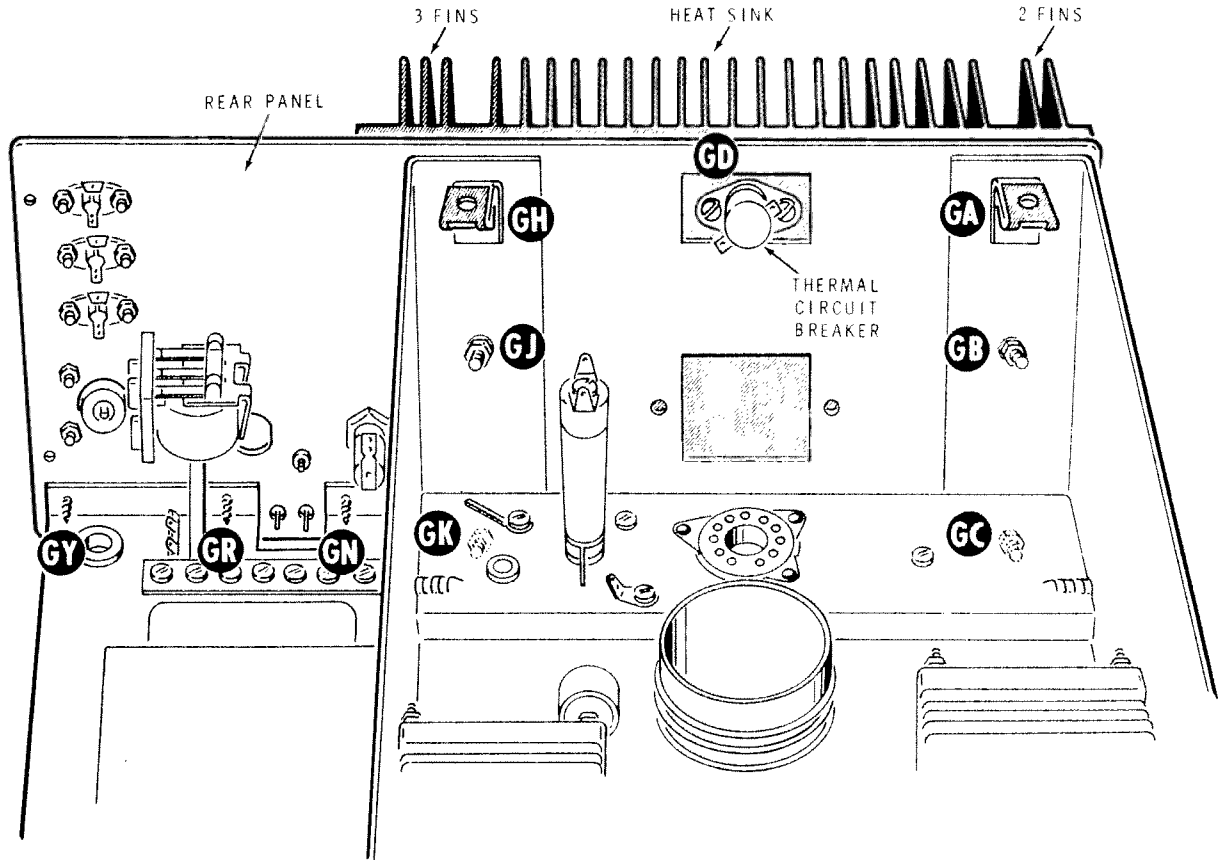

PICTORIAL 27

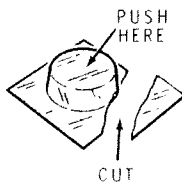

Detail 27A

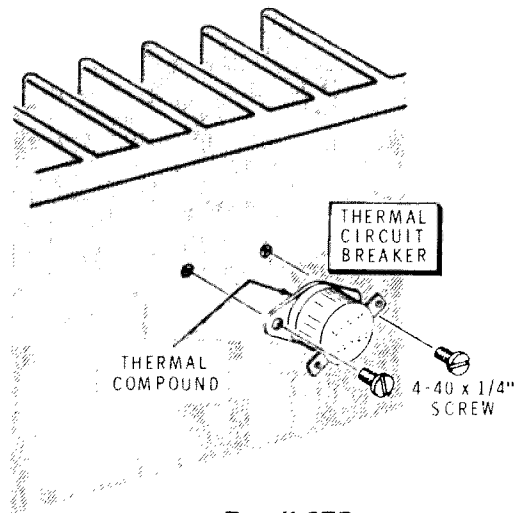

Detail 27B

Refer to Pictorial 27 for the following steps.

- (X) Refer to Detail 27A and open one of the thermal compound pods by cutting across the corner and into the pod just enough to make a small opening. Use diagonal cutters or scissors.
- (X) Refer to Detail 27B and squeeze out an amount of thermal compound equal to a medium sized pea; then smear it evenly over the back of the thermal circuit breaker. **WASH YOUR HANDS.**

- (A) TC1: Refer to Detail 27B and mount the thermal circuit breaker on the heat sink at the location shown. Use 4-40 x 1/4" screws. If you get any of the thermal compound on your fingers while mounting the thermal circuit breaker, wash your hands again.

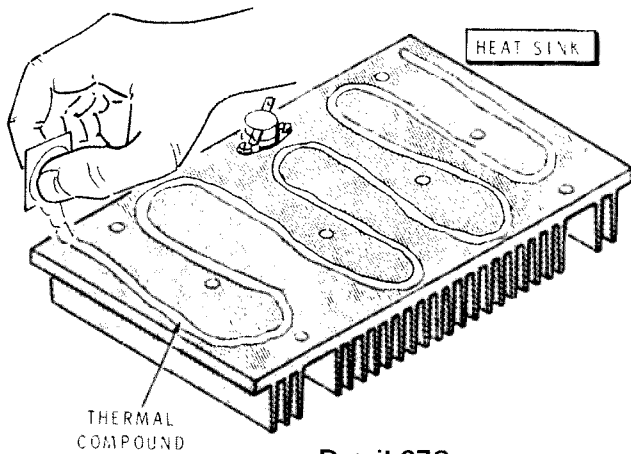

Detail 27C

- Refer to Detail 27C and make lines of thermal compound on the face of the heat sink. DO NOT use more than two pods. KEEP the compound at least 1/2" from the holes in the heat sink.

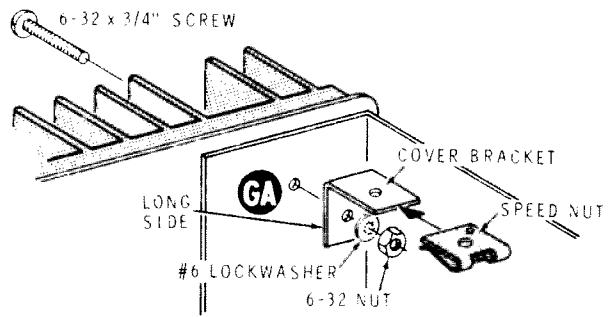

Detail 27E

Refer to Detail 27E for the following two steps.

- Mount cover brackets at GA and GH. Use 6-32 x 3/4" hardware. Position the long side as shown.
- Push a 6-32 Speed Nut onto each bracket so the holes in the nuts and brackets are aligned. The curved lip of each nut must be on the under side of the bracket.
- Tighten all heat sink hardware.

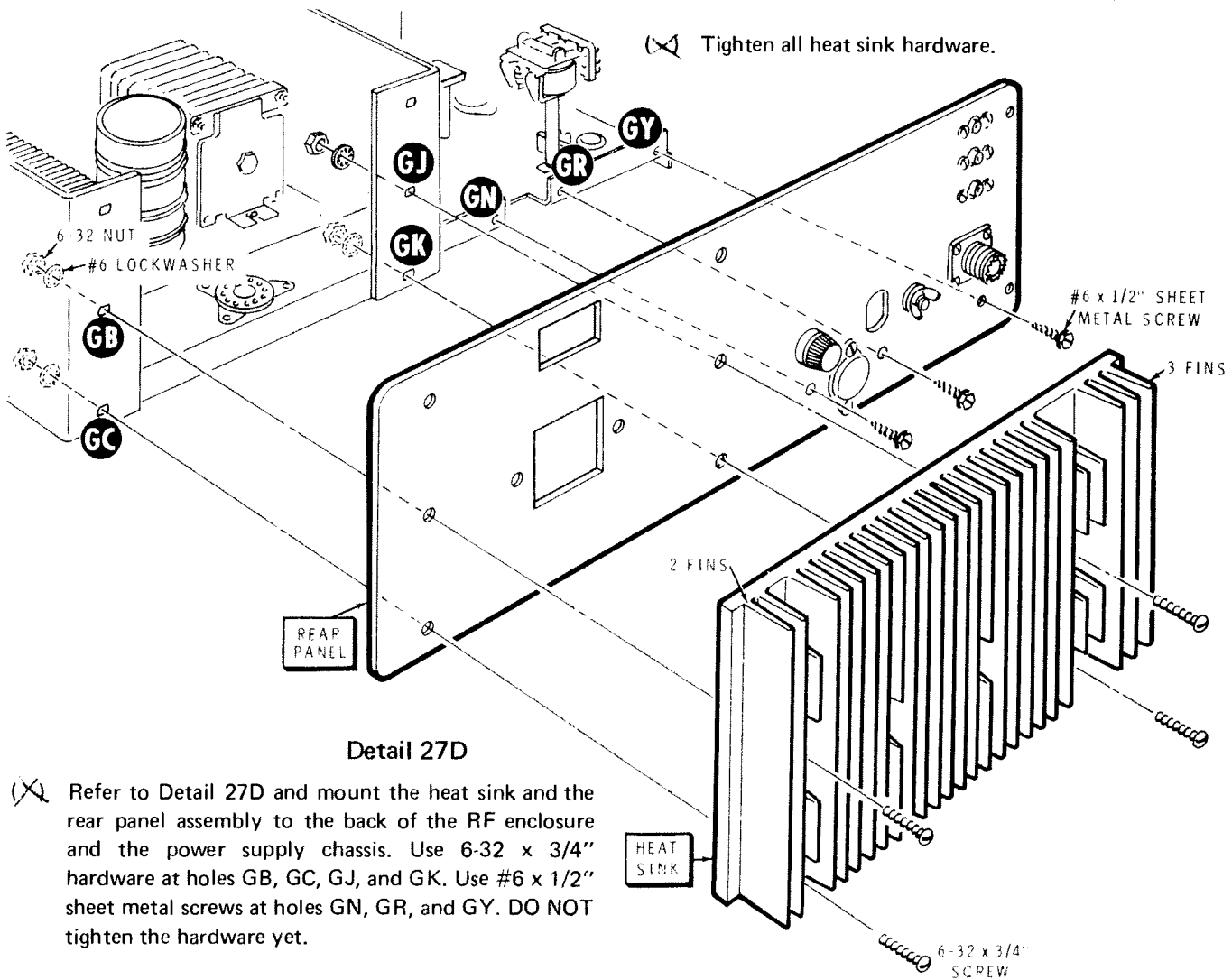

Detail 27D

- Refer to Detail 27D and mount the heat sink and the rear panel assembly to the back of the RF enclosure and the power supply chassis. Use 6-32 x 3/4" hardware at holes GB, GC, GJ, and GK. Use #6 x 1/2" sheet metal screws at holes GN, GR, and GY. DO NOT tighten the hardware yet.

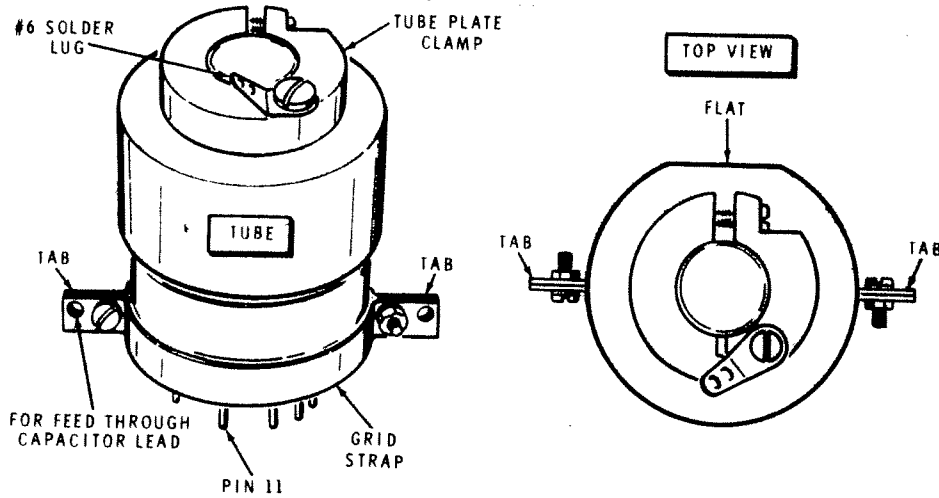

PICTORIAL 28

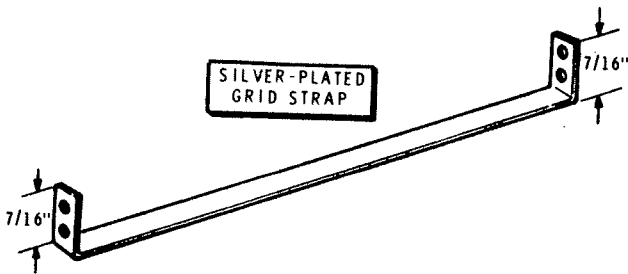

Refer to Pictorial 28 for the following steps.

- () Remove the type 8873 tube from its package. HANDLE THE TUBE CAREFULLY—it is expensive.

Refer to Detail 28A for the following two steps.

- () Bend 7/16" of each end of the two silver-plated grid straps (#212-45) as shown.

- () Form the silver-plated grid straps around the grid ring of the tube. Use 2-56 x 3/8" hardware. Place the protruding tabs so they are positioned as shown in Pictorial 28 and tighten the hardware. Note that the hardware on one side of the tube is installed opposite to the hardware on the other side.

Refer to Detail 28B for the next two steps.

- () Mount a #6 solder lug on the tube plate clamp. Use a 6-32 x 1/4" screw. Position the solder lug as shown.

- () Start a 3-48 x 7/16" brass screw into the tube plate clamp. Place the plate clamp on the tube with the opening in the clamp toward the flat on the tube. Then tighten the screw.

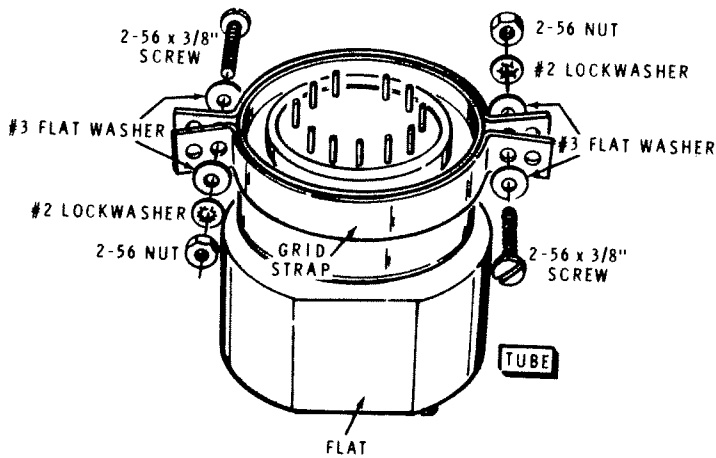

Detail 28A

BERYLLIUM OXIDE CERAMIC BLOCK

CAUTION:

Dust and fumes of Beryllium Oxide are **DEADLY POISONOUS** and should not be inhaled or brought into contact with the skin or eyes.

Do not perform any dust-producing operations (drilling, chipping, crushing, sawing, or filing) on the block.

Do not heat it over 1,000°C (unit operation will not exceed 400°C).

Wash hands after handling.

If it is dropped, remove any chips and dust with a wet towel, which should be discarded in a sealed plastic bag – do not sweep or vacuum.

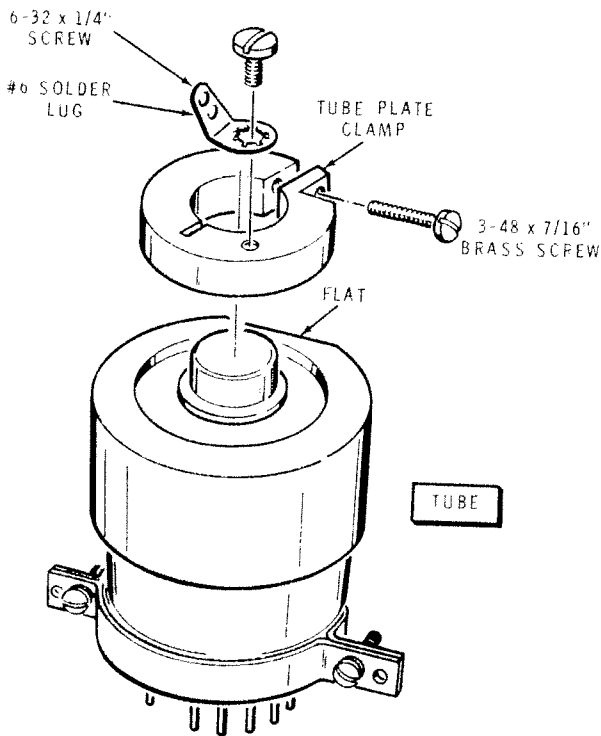

Detail 28B

Refer to Pictorial 29 (fold-out from Page 71) for the following steps.

- () Refer to Detail 29A and carefully remove the beryllium oxide block from its packaging. Apply a 1/16" thick coating of thermal compound to one side. Then place this side against the heat sink at opening

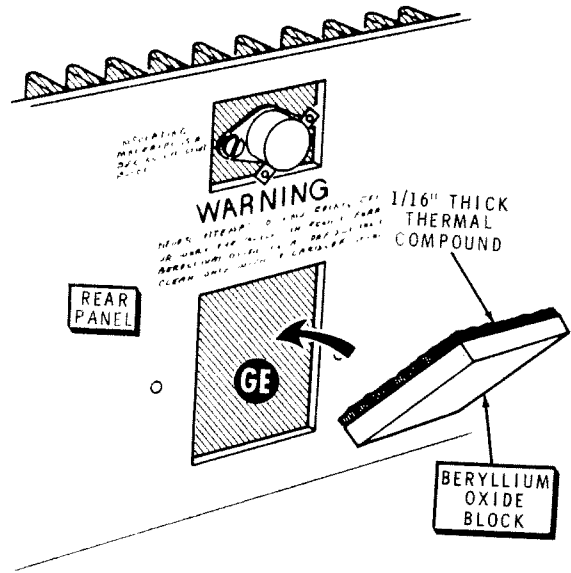

Detail 29A

GE in the rear panel. Rotate the block back and forth slightly to insure adequate contact between the beryllium block, the compound, and the heat sink.

- (X) Coat the flat side of the tube with a 1/16" thick coating of thermal compound.
- (X) V1: Insert the tube into its socket. As you seat the tube, wiggle it against the beryllium oxide block so the thermal compound will form a solid bond with the beryllium oxide block.
- () WASH YOUR HANDS.



NOTES:

1. Be very careful when forming the lead and mounting each feedthrough capacitor in the following steps, as the ceramic body can be broken.
2. In the two following steps, turn the nuts finger tight only, as the position of the two capacitors will be adjusted later.

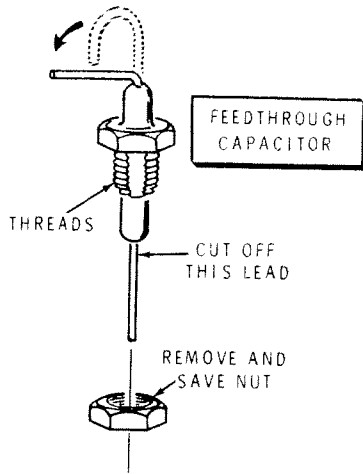

Detail 29B

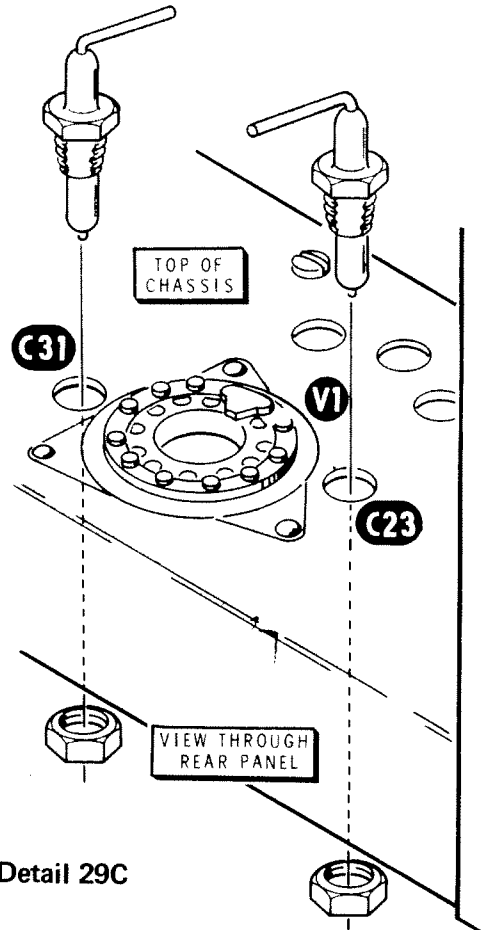

Detail 29C

- ~~Z~~ Refer to Detail 29B and, at the end opposite the threads, carefully straighten and bend the lead of each feedthrough capacitor as shown.
- ~~Z~~ Cut off the lead at the threaded end of each capacitor.
- ~~Z~~ Remove the nut from each feedthrough capacitor.
- () C23: Refer to Detail 29C and insert one of the feedthrough capacitors into hole C23 from the top of the rear of the chassis, as shown. Secure the capacitor on the bottom of the chassis with the nut removed in the preceding step.
- ~~Z~~ C31: Similarly, mount the other feedthrough capacitor in hole C31, except that the bent lead should point toward the front of the chassis.

Refer to Detail 29D for the next five steps.

- ~~Z~~ From the back of the heat sink, insert 8-32 x 3" screws into holes GF and GG. Start these screws into the two tapped holes of the tube mounting bracket.

- ~~X~~ Insert the small tip of the white insulator (#75-701) into the center hole of the tube mounting bracket and the other end of the insulator against the tube body. Then tighten the two long screws until the tube mounting bracket just starts to bow.
- ~~X~~ Solder one tab on the grid strap to the lead of capacitor C23.
- ~~X~~ Solder the other tab on the grid strap to the lead of capacitor C31.
- ~~X~~ After the solder has cooled, tighten the nuts on the two feedthrough capacitors.

- ~~X~~ Refer to Detail 29E and prepare a ferrite bead assembly:

1. Bend down 1/4" of the end of a 3" bare wire.
2. Thread two ferrite beads onto the wire.
3. Bend a 1/8" "dog leg" to retain the beads at one end of the wire.

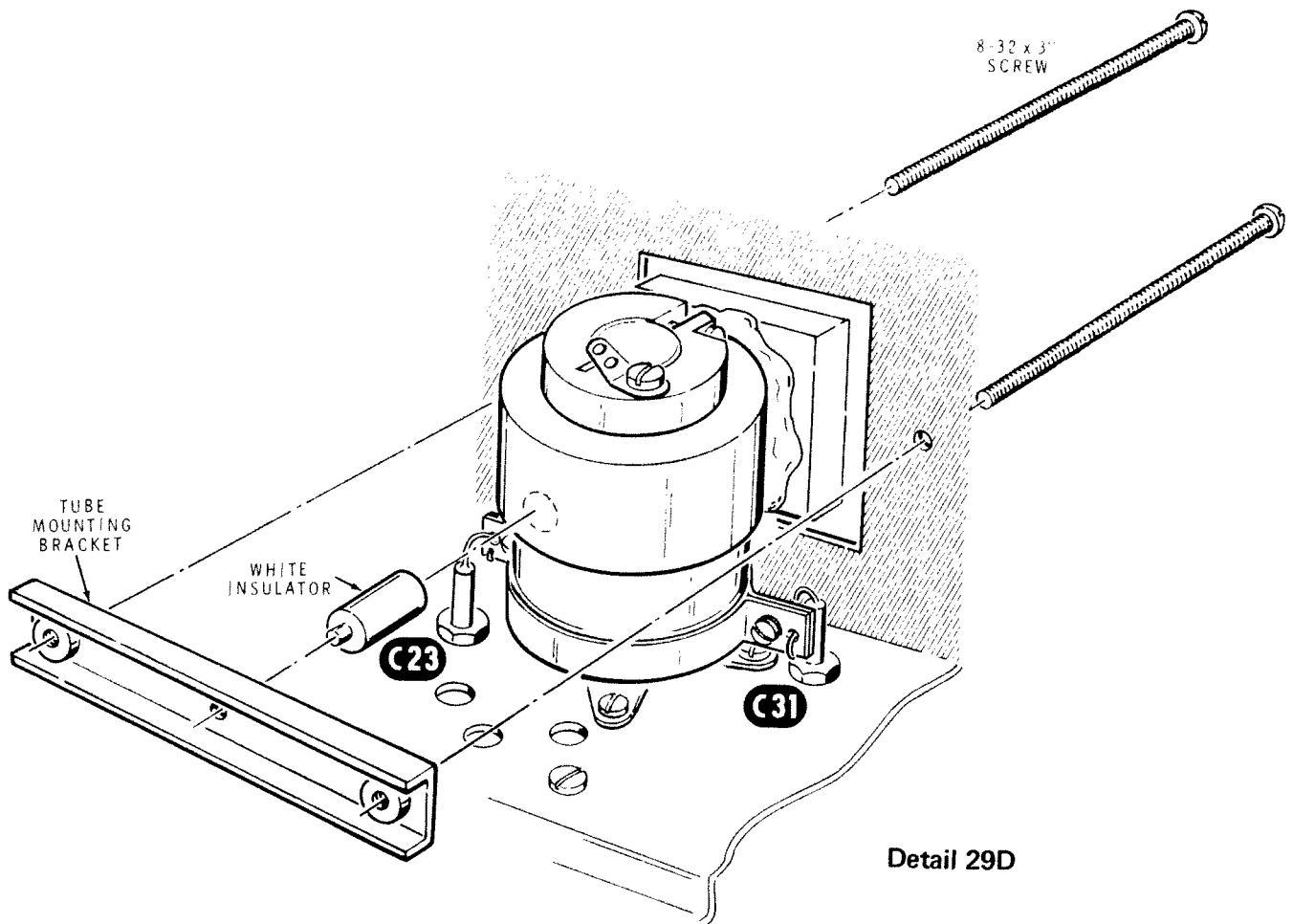

Detail 29D

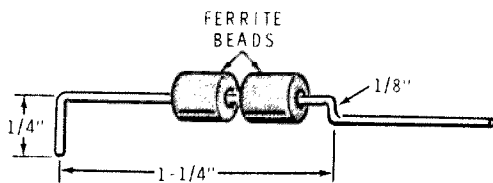

Detail 29E

Push the straight end of the ferrite bead assembly through the solder lug on the tube plate clamp (NS). Bend the solder lug up as necessary. Drop the other (bent) end of the wire into the solder lug on the upper end of the RF choke CM (S-1). Use the hole nearest the solder lug screw.

- Connect a 3-1/2" bare wire from the solder lug at BE (S-1) to the solder lug on the tube plate clamp (S-2).
- Connect the white wire coming from grommet BF of the RF enclosure to thermal circuit breaker GD lug 2 (S-1).
- Connect the black wire coming from grommet BF of the RF enclosure to thermal circuit breaker GD lug 1 (S-1).
- Prepare a 14" large blue wire.
- From the bottom of the chassis, push this blue wire up through grommet CL and connect it to RF choke CM at the bottom lug (S-2).



Refer to Pictorial 30 (fold-out from this page) for the following steps.

- (X) Prepare a 7" yellow wire. Connect one end of the wire to the solder lug on the end of the fuseholder (S-1). Push the other end of the wire through grommet BG.

CAUTION: To avoid damage to the relay solder lugs, form and fit the bare wires in the following steps before you solder either end.

- (X) Refer to Detail 30A, form a 1-1/2" bare wire to connect coaxial fitting J4 (S-1) to relay lug 7 (S-2). At the relay, form the wire so it touches the relay lug and the resistor lead.

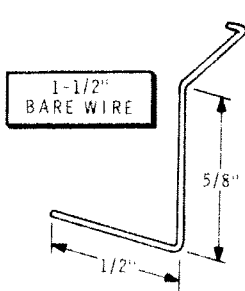

Detail 30A

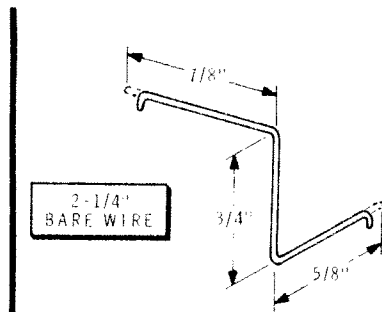

Detail 30B

- (X) Refer to Detail 30B and form a 2-1/4" bare wire to connect relay lug 10 (S-1) to phono socket J3 at its center terminal (S-1).

- (X) Connect the twisted shield wires of the coaxial cable to phono socket J3 at its ground lug (S-1). Cut off any excess shield braid. Make sure the shield wires clear the center terminal of the phono socket by at least 1/4".

- (X) Connect the yellow wire coming from the meter switch to phono socket J2 at its center terminal (S-1).

- (X) Prepare a 22-1/2" white-yellow wire. Connect one end of this wire to phono socket J1 at its center terminal (S-1). Push the other end of the wire down through grommet EC.

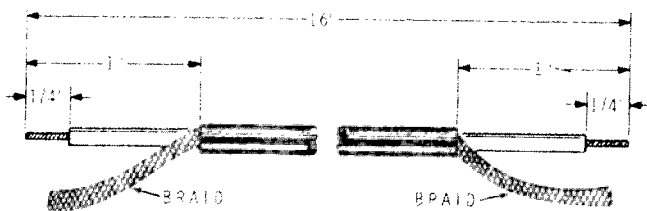

Detail 30C

- (X) Refer to Detail 30C and prepare a 16" length of coaxial cable.

- (X) At one end of the cable, connect the inner conductor to relay lug 6 (S-1). Push the shield wires through a 1/2" length of small clear sleeving and connect the wires to the solder lug between the spacer and the relay (S-1). Push the other end of the cable down through grommet EC.

- (X) Prepare an 18" large blue wire and solder a female connector on one end. Position this end of the wire over the long lug at DE. Push 5" of the other end of this wire down through grommet DC.

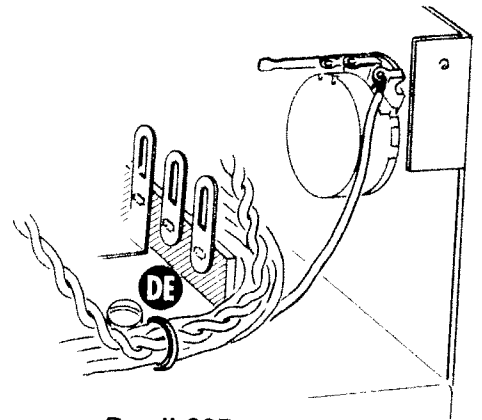

Detail 30D

- (X) Refer to Detail 30D and bend the long lug at DE so it encircles all the wires which pass it, including the brown twisted pair.

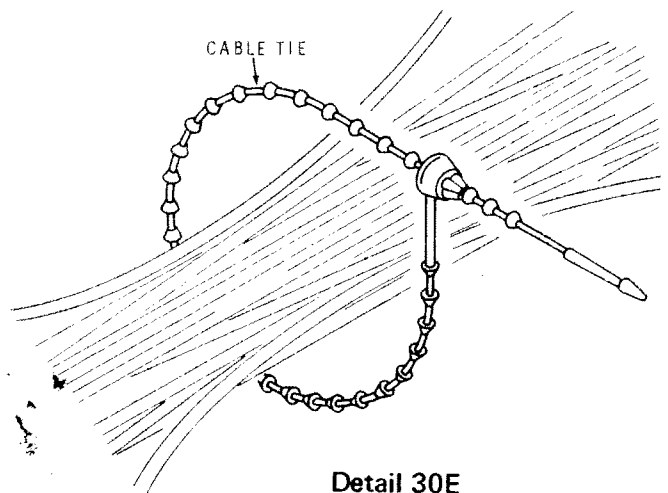

Detail 30E

- (X) Refer to Detail 30E and place a cable tie around all the wires at DN. Pull the tie up snugly and cut off all but 1/4" of the excess tie length.

Refer to Pictorial 31 (fold-out from this page) for the following steps.

- (X) Prepare two 7" small brown (tinned) wires. Form a twisted pair.
- (X) Connect the wires at one end of the twisted pair to socket EA, lugs 1 (S-1) and 6 (S-1).
- (X) Push the other end of the twisted pair through grommet EN and connect it to terminal strip TE, lugs 1 (NS) and 2 (NS).
- (X) Connect the blue wire coming from grommet DT to the solder lug at DZ (S-1).
- (X) Form a twisted pair from the two green wires coming from grommet DT. Push the twisted pair through grommet EN.
- (X) Connect one wire of the green twisted pair to terminal strip TE lug 2 (S-3), and connect the other wire to lug 1 (S-3).
- (X) Push the white-yellow wire coming from grommet EC through grommet EN. Position this wire in the chassis corners and connect it to terminal strip TA lug 6 (S-3).
- (X) Push the white wire coming from grommet EC through grommet EN and connect it to terminal strip TC lug 2 (NS).
- (X) Push the violet wire coming from grommet DC through grommet EN and connect it to terminal strip TC lug 2 (S-2).
- (X) Push the white-blue wire coming from grommet DC through grommet EN and connect it to terminal strip TC lug 1 (S-2).
- (X) Twist the long lug at BR around the violet, white-black, and white-blue wires to hold them in place.

Refer to Pictorial 32 for the following steps.

- (X) Push the coaxial cable coming from grommet EC through grommet EN, between terminal strip TC and the chassis lip, and under the ends of the two terminal boards. Connect the cable to terminal strip TA: the shield wires to the lower hole of lug 3 (S-1) and the inner conductor to the lower hole of lug 1 (S-1).

- (X) Connect the yellow wire coming from grommet BG to terminal strip TD lug 4 (S-3).
- (X) Push the large blue wire coming from grommet CL through grommet EN and connect it to capacitor C3 lug ES (NS).
- (X) Connect the large blue wire coming from grommet DC to capacitor C3 lug ES (NS). Pull any excess wire back through grommet DC.
- (X) Connect the red-yellow wire coming from grommet DC to capacitor C6 lug ET (S-3).
- (X) R15: Connect a 100 kΩ (brown-black-yellow) resistor to terminal strip DE between lugs 1 (S-1) and 2 (NS).
- (X) Refer to Detail 32A and prepare a 3-megohm resistance assembly from three 1 megohm, 2-watt (brown-black-green) resistors and a 3" length of large clear sleeving.

① CUT LEADS OF 1MΩ (BROWN-BLACK-GREEN), 2-WATT RESISTOR AS SHOWN.

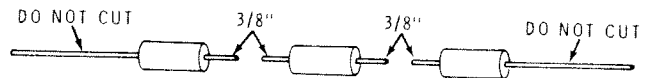

② FORM HOOKS IN THE 3/8" LEADS.



③ HOOK RESISTORS TOGETHER AND SOLDER.

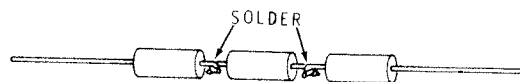

④ SLIDE 3" OF CLEAR SLEEVING OVER RESISTORS.



Detail 32A

- (X) R12, R13, R14: Position the 3-megohm resistance assembly as shown in the Pictorial. Slide a 1" length of small black sleeving on one lead and connect it to capacitor C3 lug ES (S-4). Connect the other lead to terminal strip DE lug 2 (S-3).

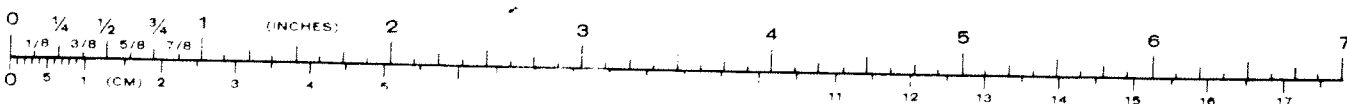

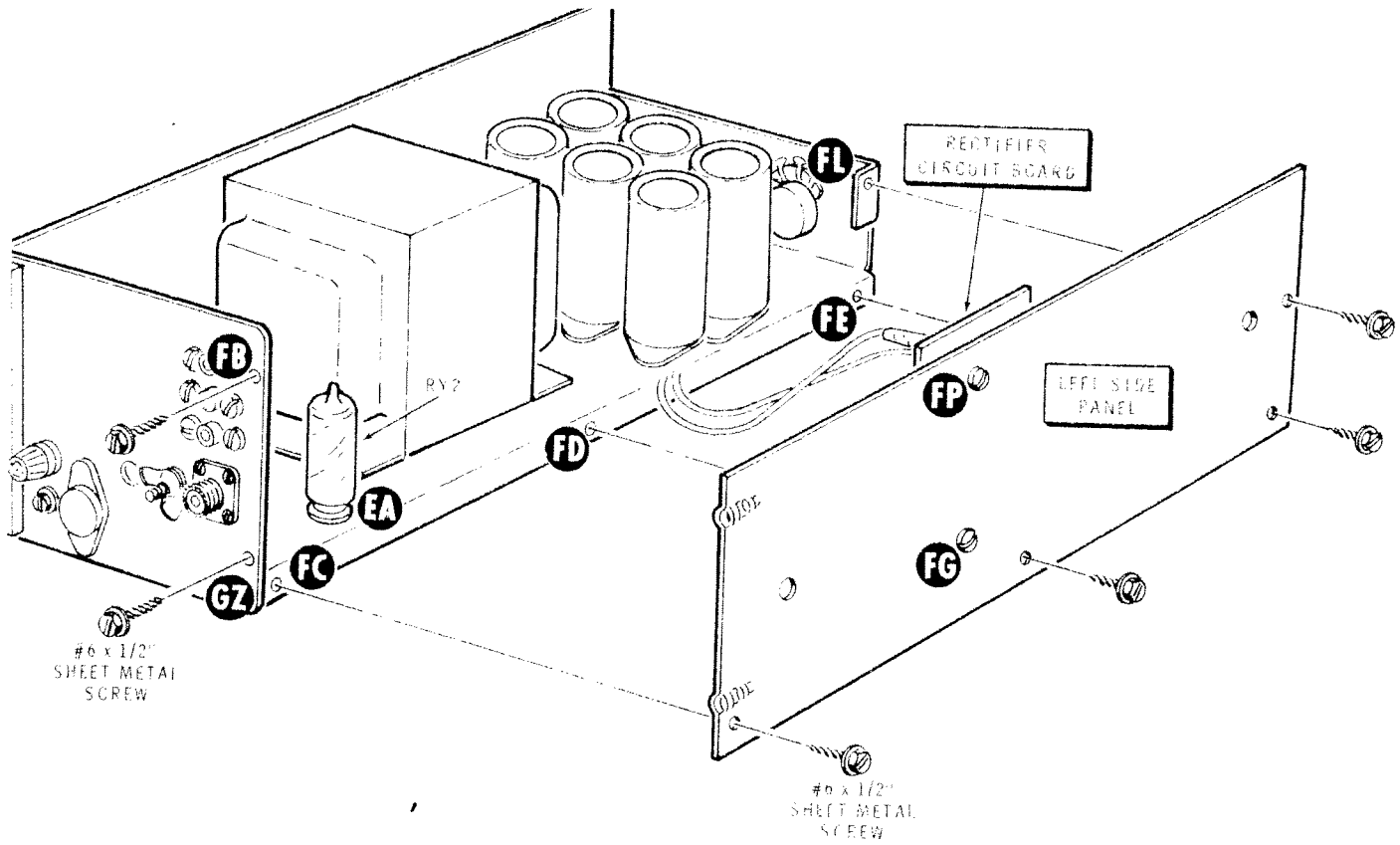

PICTORIAL 33

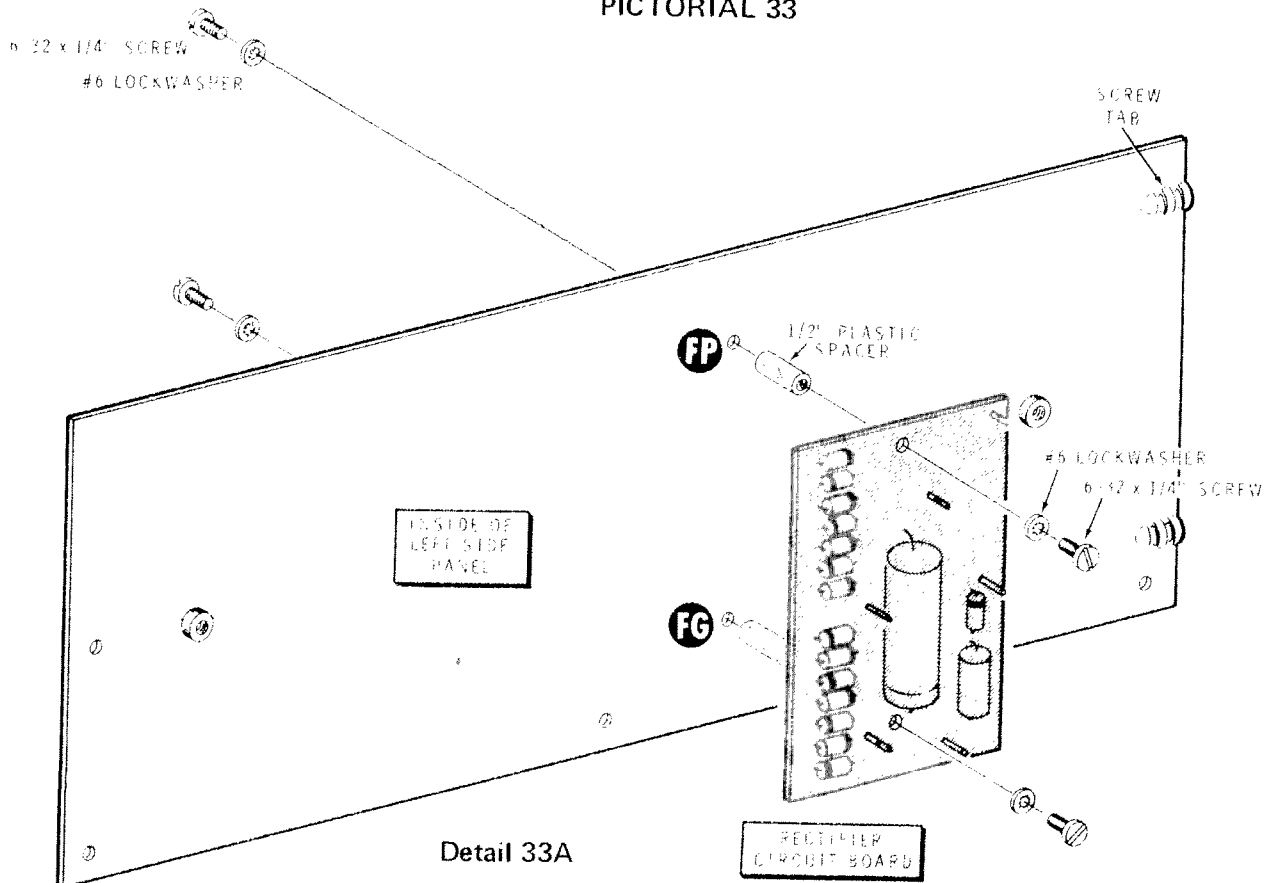

Detail 33A



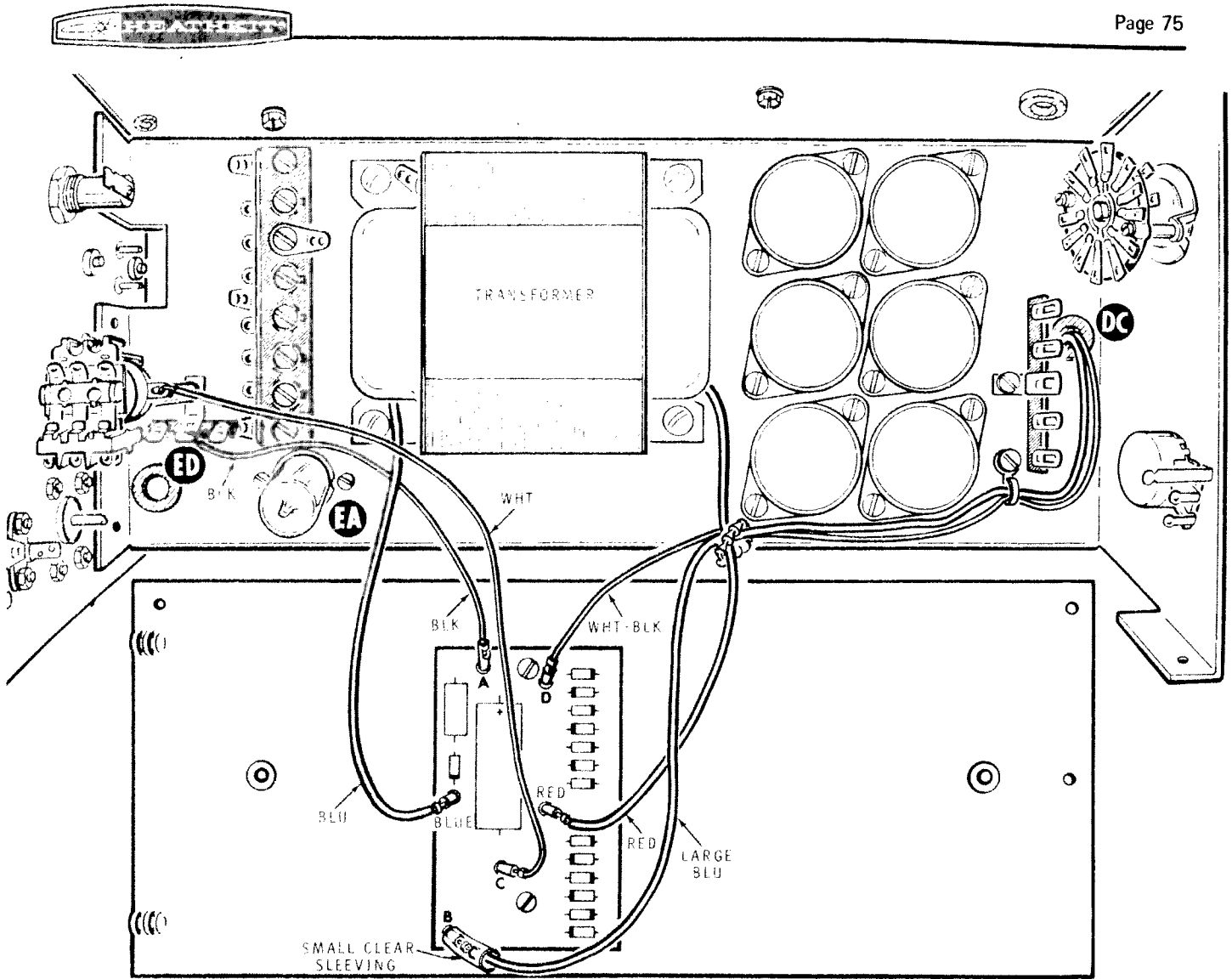

Detail 33B

Refer to Pictorial 33 for the following steps.

- (X) Refer to Detail 33A and mount the rectifier circuit board at FG and FP on the left side panel. Use 1/2" plastic spacers, 6-32 x 1/4" screws, and #6 lockwashers. Position the screw tabs as shown in the Detail.

Refer to Detail 33B for the following seven steps.

- (X) Push the connector on the black wire coming from terminal strip ED onto pin A on the circuit board.
- (X) Push the connector on the white-black wire onto pin D.
- (X) Push the connector on the blue transformer lead onto pin BLUE.

- (X) Push the connector on the red transformer lead onto pin RED.
- (X) Push the connector on the white wire onto pin C.
- (X) Slide a 1-1/2" length of small clear sleeving onto the large blue wire coming from grommet DC. Push the connector on this wire onto pin B on the circuit board. Then push the clear sleeving along the wire until it touches the circuit board.
- (X) RY2: Install the time delay relay in socket EA.
- (X) Secure the left side panel to the power supply chassis. Make sure no wires are pinched between the panel and the chassis. Use #6 x 1/2" sheet metal screws at FC, FD, FE, and FL on the left side panel and at FB and GZ on the rear panel. Look under the chassis to make sure no wire insulation has been damaged by the attaching screws.

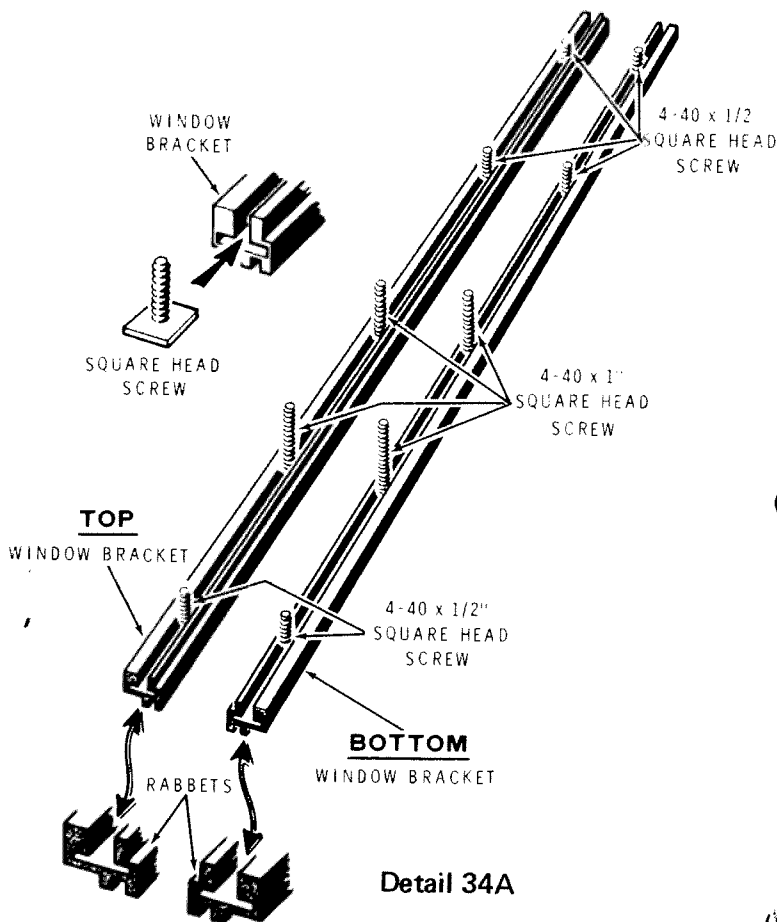

Detail 34A

Refer to Pictorial 34 (fold-out from Page 79) for the following steps.

- (X) Refer to Detail 34A and slide 4-40 x 1/2" and 4-40 x 1" square head screws, arranged as shown, into the slots of two window brackets. Arrange the brackets with the rabbets facing each other.

Refer to Detail 34B (fold-out from Page 79) for the next six steps.

- (X) Insert the five screws in each bracket into the holes at AA, AB, AC, AD, and AE. Temporarily place #4 lockwashers and 4-40 nuts onto the two screws at AE. Leave the nuts loose. Be sure that the rabbets in the edges of each bracket, face each other as shown.

NOTE: If there is protective paper on one side of the red window, remove it.

- (X) Wash the red window with soap and water to remove all finger prints. After washing, handle the window only by the edges.

- (X) Hold the red window against the light so the words read correctly. If you have some clear, adhesive tape, position the diffuser strip back of the wording on the

window with the right end of the window diffuser strip 1" in from the right end of the window. If you do not have the tape, the diffuser strip will be installed later.

- (X) Grasp the red window by the edges and slide it into the rabbets in the window brackets on the panel. Make sure the wording reads correctly and is centered in front of the panel opening.

- (X) If you did not tape the diffuser strip to the back of the red window, slide the diffuser strip into the rabbets between the red window and the panel. Adjust the strip so it covers the entire lamp housing opening.

- (X) Tighten the nuts at AE finger tight.

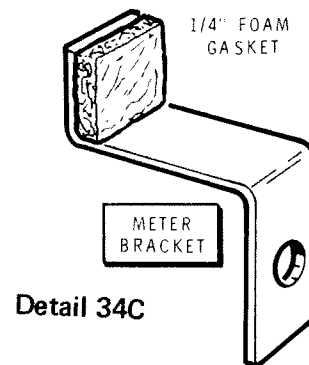

Detail 34C

- (X) Refer to Detail 34C and cut two 1/4" lengths of foam strip. Remove the protective covering and press each piece onto the lip of a meter bracket.

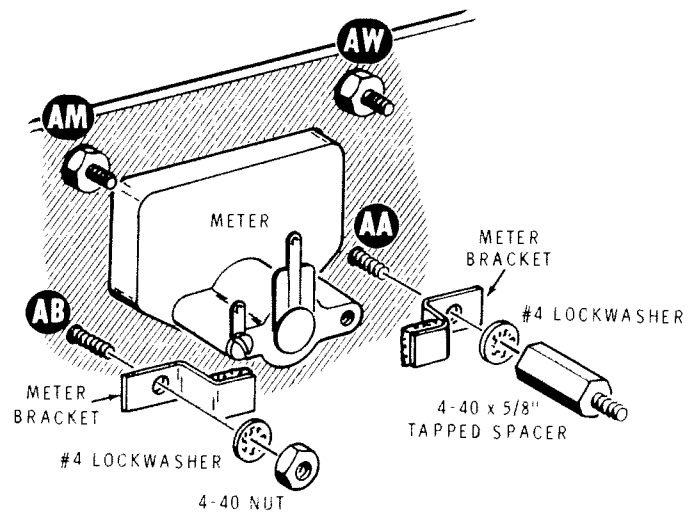

Detail 34D

Refer to Detail 34D for the next four steps.

- (X) Mount a meter bracket on the back of the panel on screw AB. Use a #4 lockwasher and a 4-40 nut. Leave the nut loose.

⌘ Mount the other meter bracket on the screw at AA. Use a #4 lockwasher and a 4-40 x 5/8" tapped spacer. Leave the spacer loose.

⌘ M1: Slide the meter down between the two meter brackets until the meter face fits into opening M1 in the panel. Position the meter brackets as shown and gently tighten the 4-40 nut and the spacer. Do not overtighten.

⌘ Install #4 lockwashers and 4-40 nuts on screws AM and AW. Leave the nuts loose.

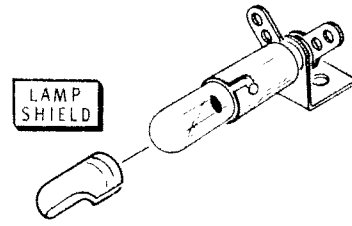

Detail 34F

⌘ Refer to Detail 34F and install a lamp shield on the lamp. Turn the shield so the opening is toward the back of the meter and so the closed portion will prevent light from shining up through the cabinet (when installed later).

⌘ Temporarily remove the control nuts and control flat washers from the shaft bushings at SW2 and R34.

PART A

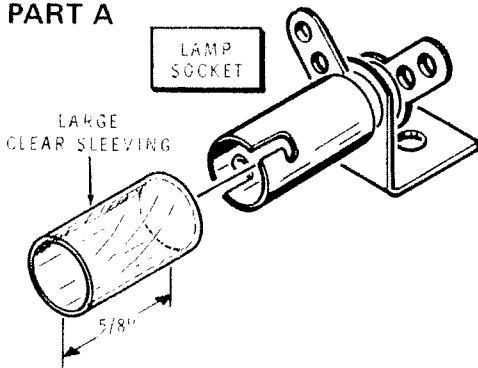

PART B

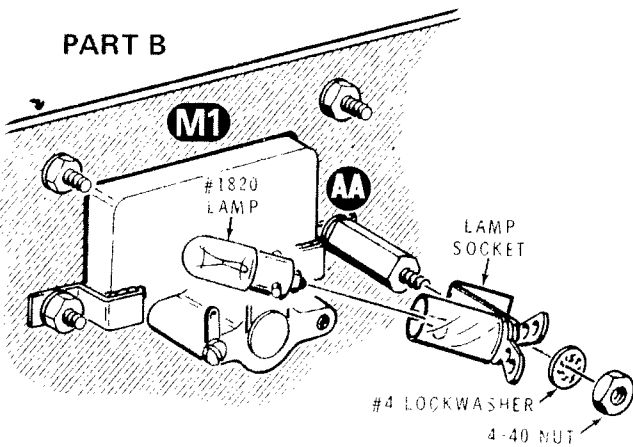

Detail 34E

⌘ Refer to Part A of Detail 34E and slide a 5/8" length of large clear sleeving onto the pilot lamp socket.

⌘ Refer to Part B of Detail 34E and mount the lamp socket on the spacer at AA. Use a #4 lockwasher and a 4-40 nut.

() Insert a #1820 lamp into the lamp socket.

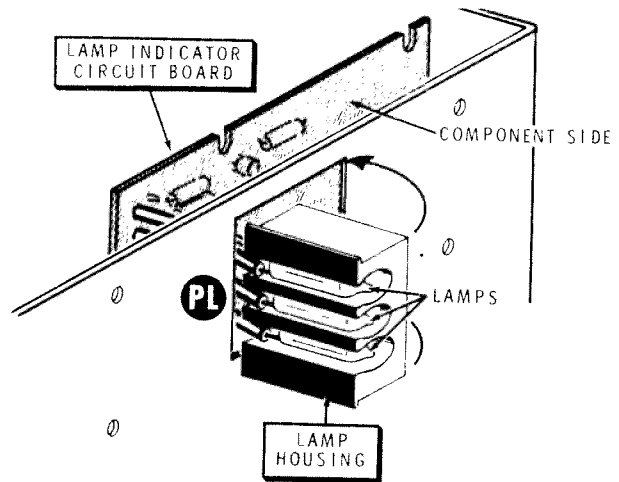

Detail 34G

Refer to Detail 34G for the following two steps.

⌘ Hold the lamp indicator circuit board with its component side toward the RF enclosure subpanel and with the three lamps extending through opening PL. Hold the lamp housing as shown and push the three lamps into the three slots in the housing.

⌘ Push the left side of the lamp housing against the left side of opening PL and swing the right side of the housing into the opening. The upper and lower housing flanges should be against the subpanel. The lamp indicator circuit board should now be hanging from the lamp leads.



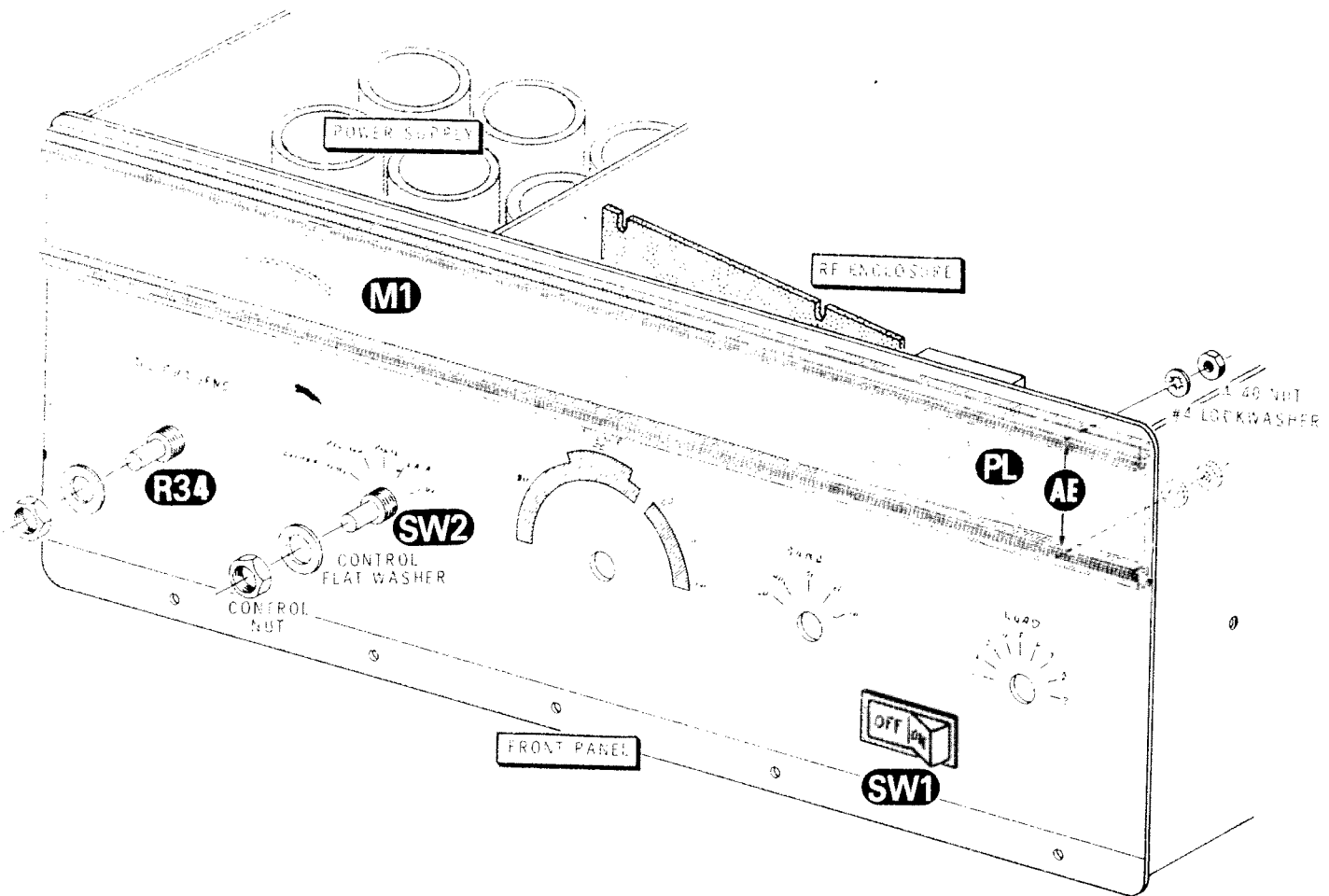

Detail 34H

- (X) Temporarily remove the nuts and lockwashers at AE.
- (X) Refer to Detail 34H and place the front panel across the front of the RF enclosure and the power supply chassis with the two shaft bushings through holes SW2 and R34, the power switch through opening SW1, and the lamp housing through opening PL. Secure the panel with the control flat washers and control nuts removed in a preceding step, #4 lockwashers, and 4-40 nuts at holes AE. The front panel should lie flat against the front of the RF enclosure. The control nuts should be only finger tight. It may be necessary to make a small adjustment in the position of SW1.
- (X) Refer to Detail 34J and place two #4 lockwashers and a 3/16" spacer on each of the four screws at AC and AD. Then mount the lamp indicator circuit board on the screws and secure it with a #4 lockwasher and a 4-40 nut on each of the four screws. Tighten the nuts finger tight only.
- (X) Refer to Detail 34K and slide the heads of five 1/2" square head screws into the channel in the lower panel trim strip. Then mount the trim strip on the lower edge of the front panel in the five holes provided. Use a #4 lockwasher and a 4-40 nut on each of the five screws.
- (X) Center the two trim strips and the red window on the panel and tighten all the nuts on both sides of the panel. Use the 1/4" end wrench for the 4-40 nuts.

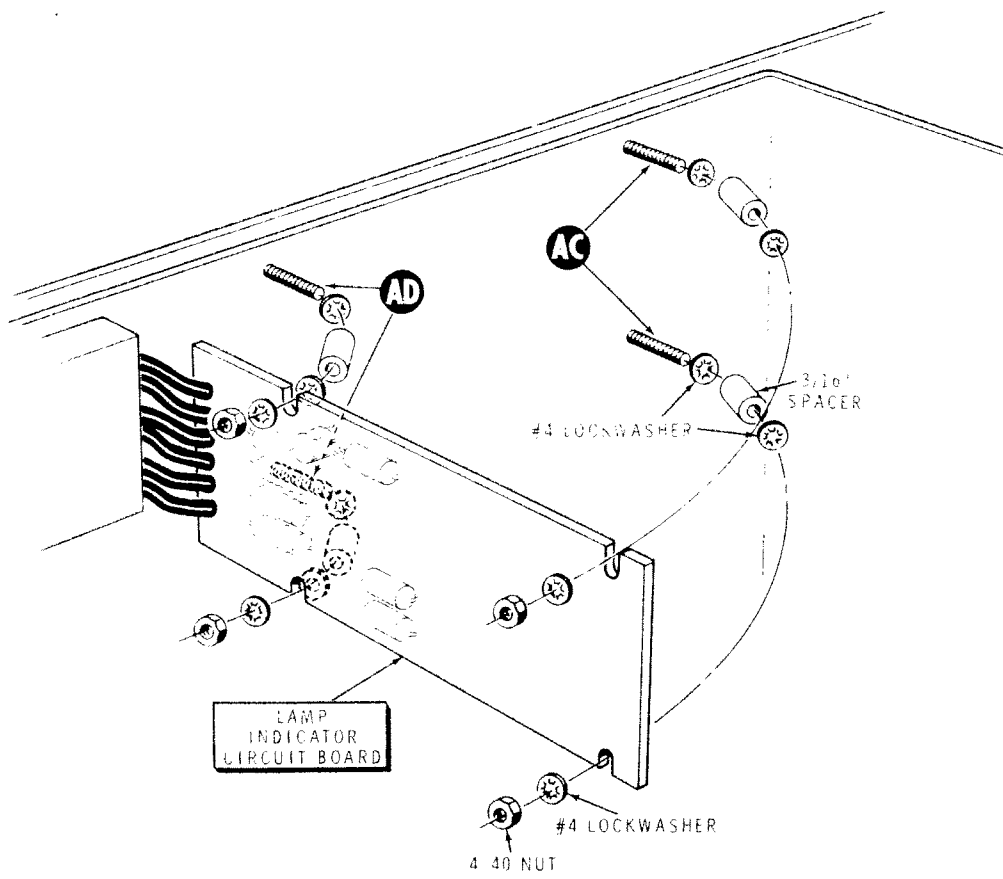

Detail 34J

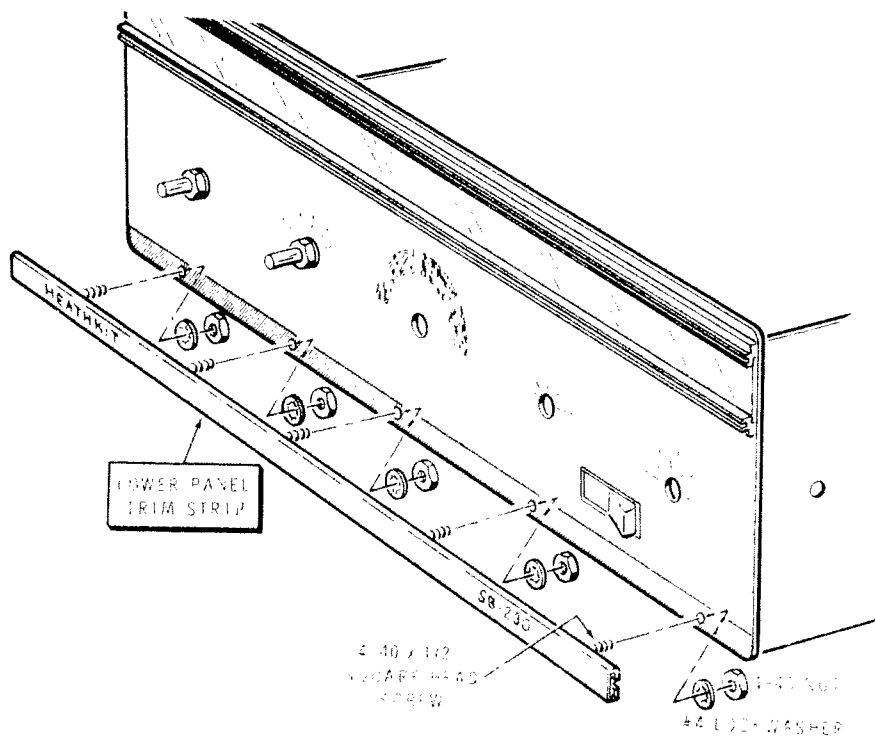

Detail 34K

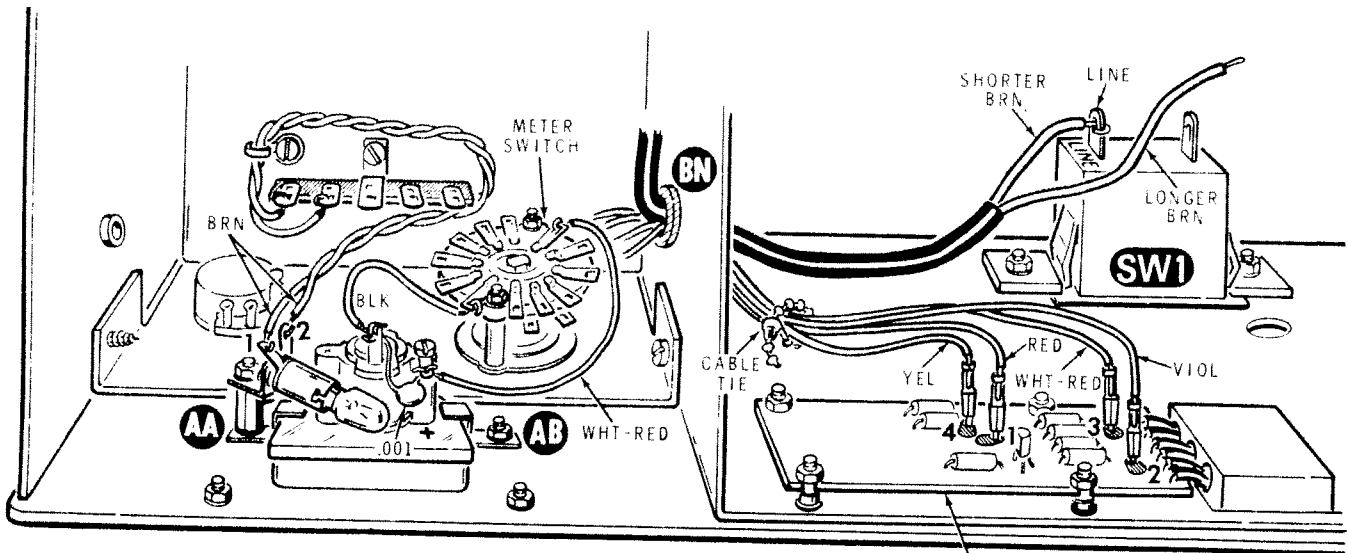

PICTORIAL 35

LAMP INDICATOR CIRCUIT BOARD

Refer to Pictorial 35 for the following steps.

- (X) Carefully inspect the back of the meter. If there is a wire between the positive and negative terminals, remove and discard it.
- (X) Bend the center (negative) terminal of the meter so it points straight back.
- (X) C18: Connect a .001 μ F disc capacitor between the two meter terminals (NS).
- (X) Connect the black wire coming from the 1-wafer switch to the negative (unmarked) meter terminal (S-2).
- (X) Connect the white-red wire coming from the 1-wafer switch to the positive (marked "+") meter terminal (S-2).
- (+) Connect the brown twisted pair to the pilot lamp socket, one wire to lug 1 (S-1) and the other wire to lug 2 (S-1).
- (S) Push the connectors on wires coming from grommet BN onto pins of the lamp indicator circuit board as follows:

- Yellow onto pin 4.
- Violet onto pin 2.
- White-red onto pin 3.
- Red onto pin 1.

- (X) Place a cable tie around the four colored wires in the preceding step, about halfway between the circuit board and the grommet. Pull the tie up snugly and cut off all but 1/4" of the excess tie length.
- (+) Refer to Pictorial 36 for the following steps.

Detail 36A

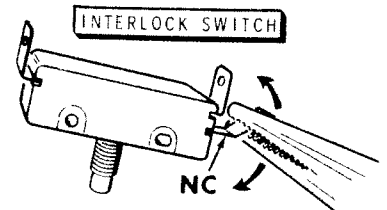

- (X) Refer to Detail 36A and identify the interlock switch lug marked NC on one side of the switch body. Grasp this lug with pliers and bend it back and forth until it breaks off. Break off this lug on both interlock switches.
- (X) SW5: Refer to Detail 36B and install an interlock switch at GT and GU on the right side of the RF enclosure. Be sure the switch button is on the underside of the switch. Use 6-32 x 1" hardware. Note the number of nuts used.
- (+) SW4: Similarly, install the other interlock switch at GW and GZ. The switch button should be on the upper side of the switch.

(+) Prepare large brown (stranded) wires as follows:

- 3-1/4"
- 5"

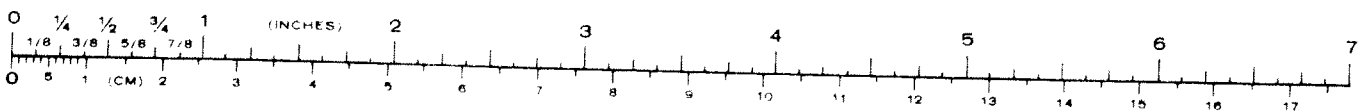

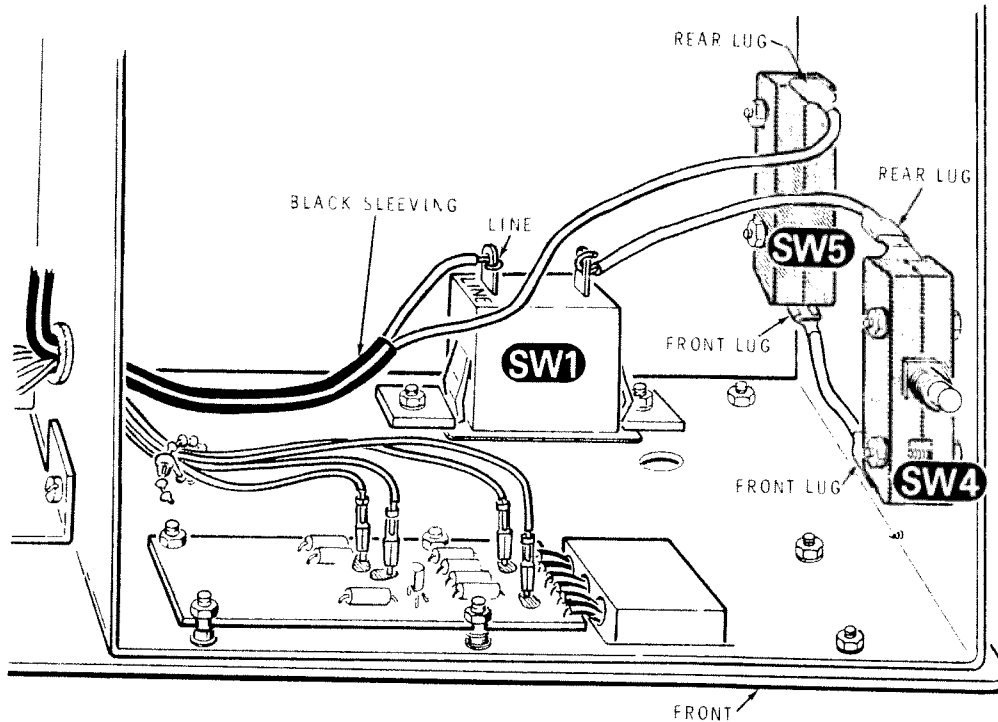

PICTORIAL 36

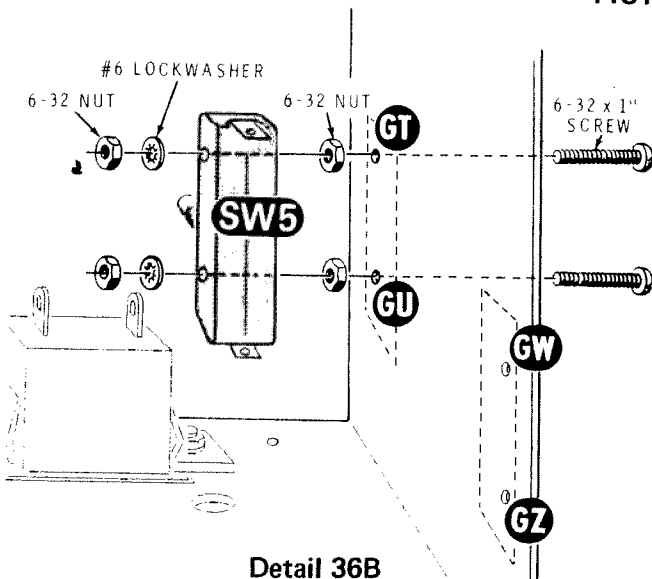

Detail 36B

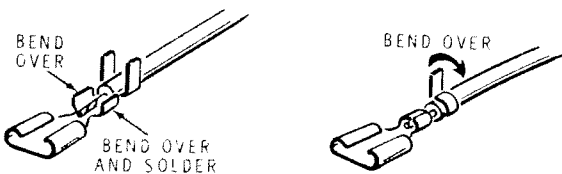
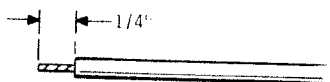

Detail 36C

- (X) Refer to Detail 36C and install push-on connectors on each end of the 3-1/4" brown wire.
 - (X) Install a push-on connector on one end of the 5" wire.
 - (X) Install a push-on connector on the end of the longer brown wire coming from the black sleeving.
 - (X) Push this connector onto the rear lug of SW5.
 - (X) Push one connector on the 3-1/2" wire onto the front lug of SW4 and the other connector onto the front lug of SW5.
 - (X) Push the connector on the 5" wire onto the rear lug of SW4.
- NOTE: In the following two steps, push each wire through the switch lug and wrap it around the lug to make a mechanically secure connection.
- (X) Connect the shorter brown wire coming from the black sleeving to SW1 at the lug marked "line" (S-1).
 - (X) Connect the brown wire coming from the rear lug of SW4 to the other lug of SW1 (S-1).

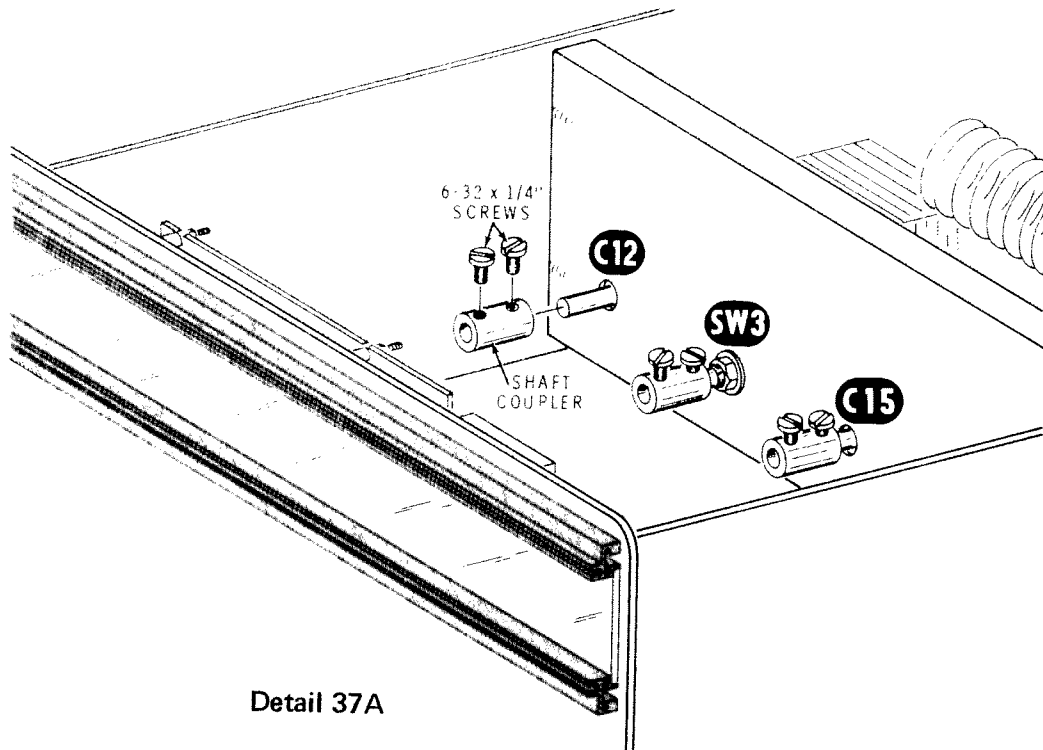

Detail 37A

Refer to Pictorial 37 (fold-out from Page 80) for the following steps:

- ✗ Turn the shafts of the two variable capacitors so their plates are fully meshed. Turn the shaft of switch SW3 fully counterclockwise.
- ✗ Refer to Detail 37A and start two 6-32 x 1/4" screws into each of the three shaft couplers.
- ✗ Push 3/8" of a shaft coupler onto each of the shafts at C12, SW3, and C15 in the front of the RF chassis. Tighten the rear screw of each coupler onto the shafts.

- ✗ Refer to Detail 37B and, from the back of the panel, install shaft bushings in holes C12, SW3, and C15 in the front panel. Use control flat washers and control nuts.

Refer to Detail 37C for the next two steps:

- ✗ Push 4-3/4" extension shafts through the shaft bushings into the shaft couplers at C12 and C15. Tighten the shaft coupler screws.
- ✗ Push a 4-3/8" extension shaft through the shaft bushing into the shaft coupler at SW3. Tighten the shaft coupler screws.

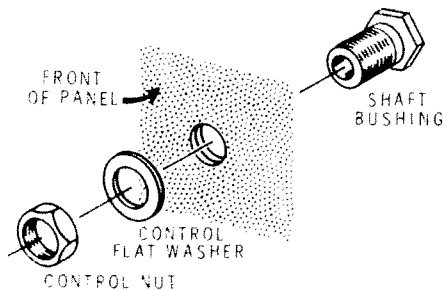

Detail 37B

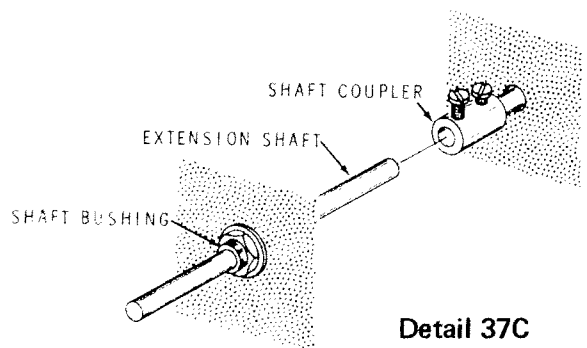

Detail 37C

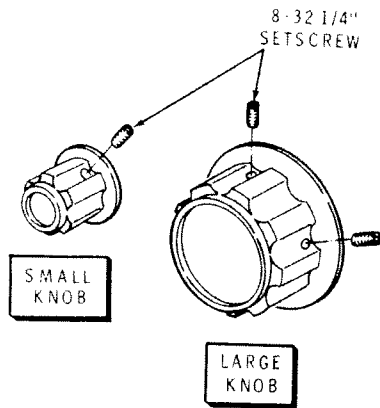

Detail 37D

Push the knobs onto the five shafts. Position the index mark of each as shown. Then tighten the setscrews in each knob (two setscrews in the large knob).

Install the perforated cover on the RF enclosure. Use #6 x 1/2" sheet metal screws.

Remove the protective backing from the "Danger" label and press its adhesive side down on the perforated cover as shown in Pictorial 37.

NOTE: The blue and white identification label shows the Model Number of your kit. Refer to these numbers in any communications with the Heath Company.

Refer to Detail 37D and start two 8-32 x 1/4" setscrews into the large knob. Start one 8-32 x 1/4" setscrew into each of four small knobs.

Install the identification label in the following manner.

Refer to Detail 37E for the following two steps.

Carefully peel away the backing paper. Then press the label into position as shown in the Pictorial. You will avoid smearing the numbers on the label if you will put the piece of waxed backing paper on top of the label and then rub on it instead of directly on the label.

Turn the shafts at Tune and Load so the capacitor plates are fully meshed. Turn all other shafts fully counterclockwise.

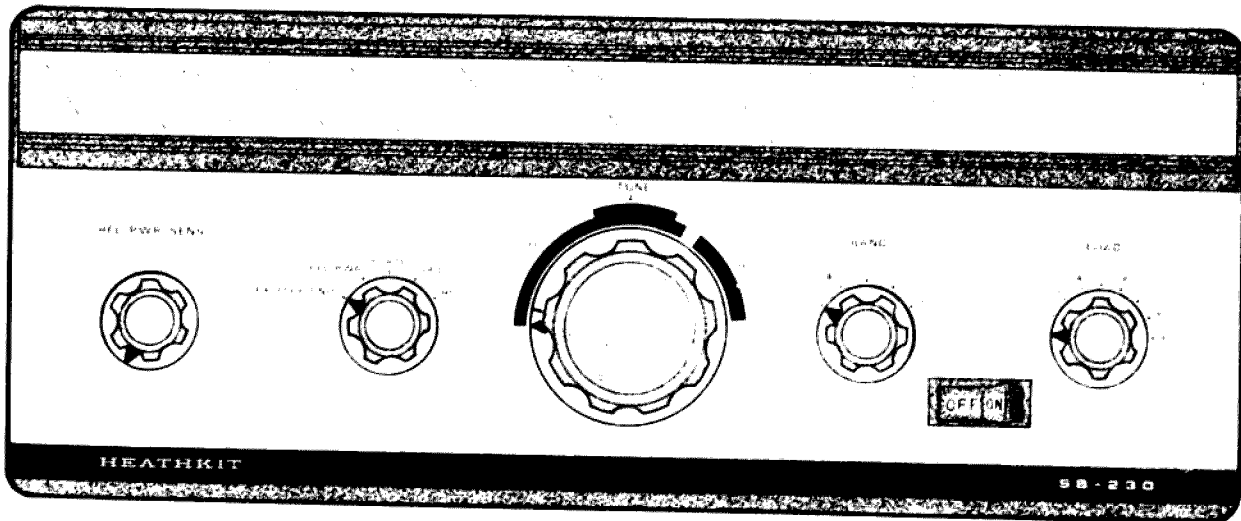

Detail 37E



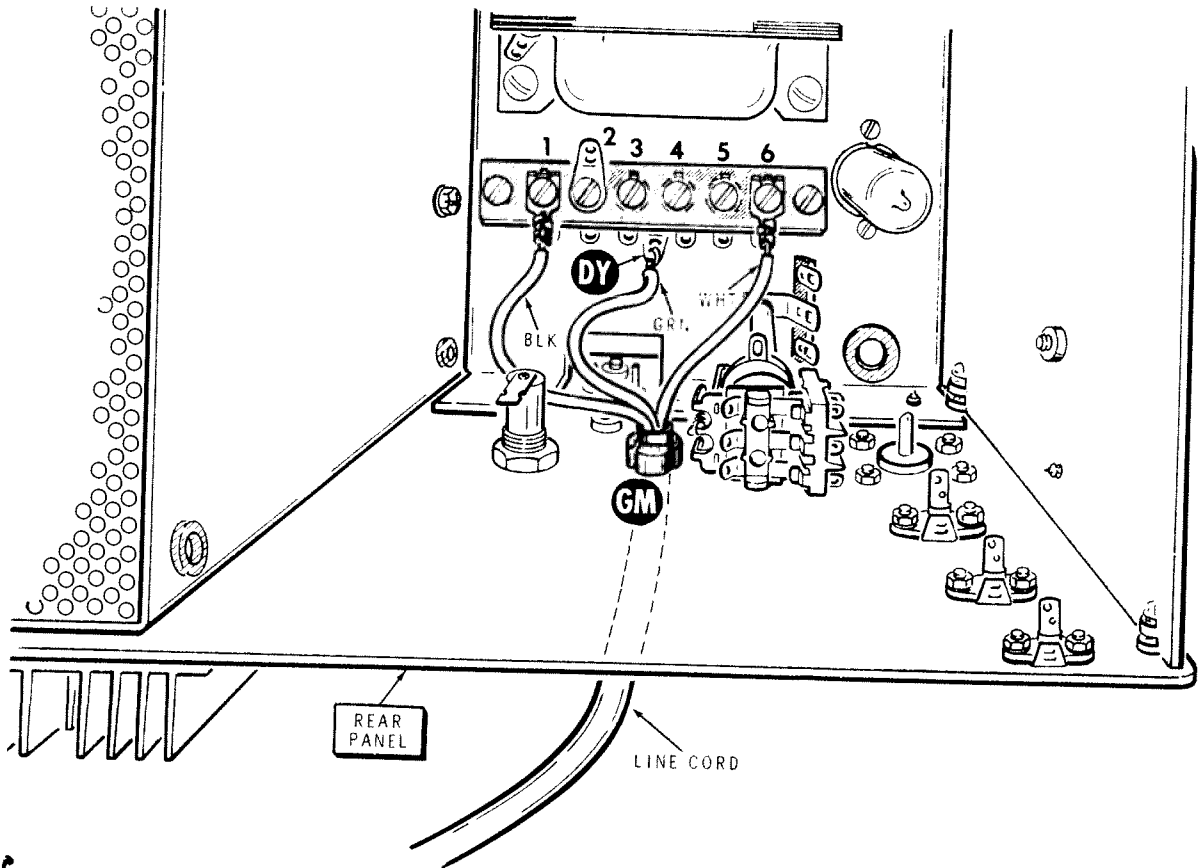

PICTORIAL 38

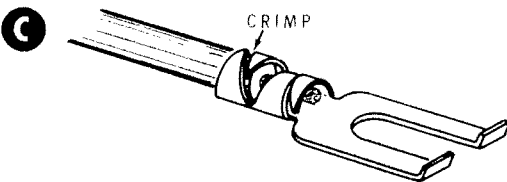
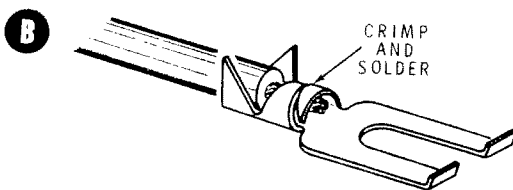
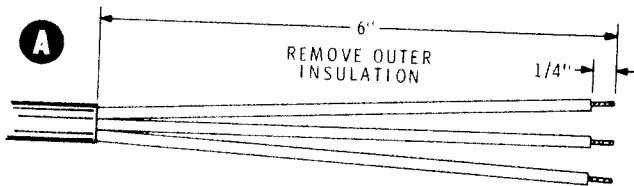

Detail 38A



Refer to Pictorial 38 for the following steps.

() If not already done, remove 1/4" of insulation from each of the three line cord wires. Twist the fine strands of each wire together and melt a minimum amount of solder on each bare end.

(X) Refer to Detail 38A and install one spade lug on the end of the black wire and another on the end of the white wire.

(X) Refer to Detail 38B, bend up the end of the green line cord wire, push it through hole GM in the rear panel, and work it into the hole in solder lug DY under the 6-screw terminal strip (S-1).

(X) Insert the white and the black line cord wires into hole GM.

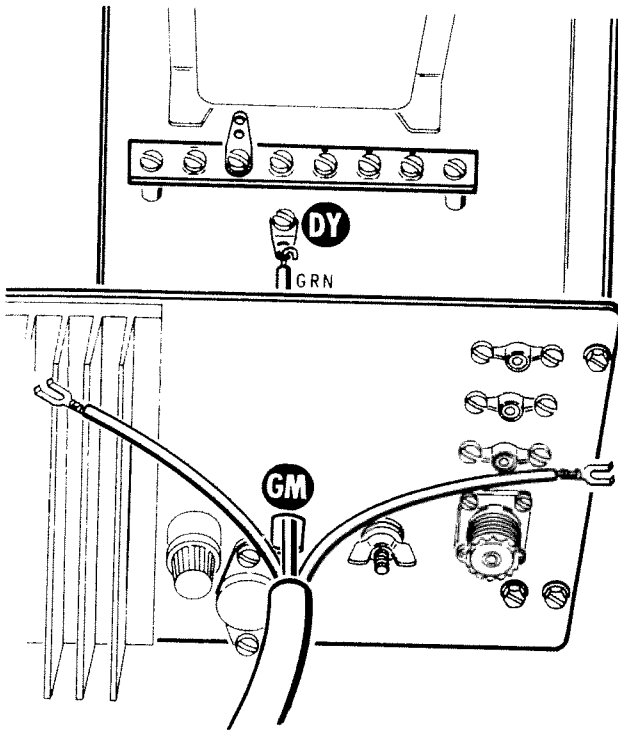

Detail 38B

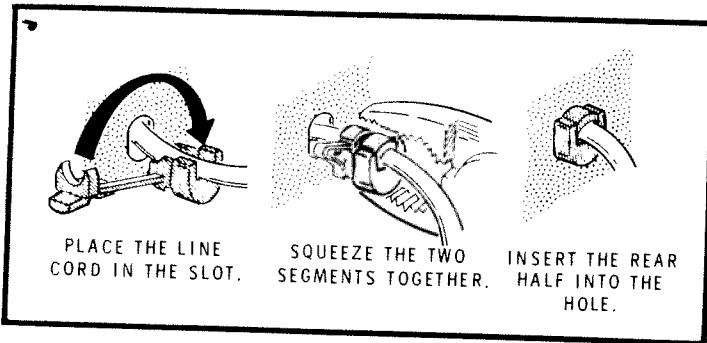

Detail 38C

(X) Refer to Detail 38C and place the strain relief 1/4" from the end of the line cord outer insulation with the smaller end of the strain relief toward the panel. To preform the cord, use pliers to compress the smaller part of the strain relief onto the line cord with as much pressure as possible, and hold the pressure for about 10 seconds. Use water-pump pliers, if you have them.

(A) Place the rounded nose of the strain relief against hole GM, and press the strain relief into the hole.

(X) Connect the solder lug on the black line cord wire under screw 1 on the 6-screw terminal strip and the solder lug on the white line cord wire under screw 6 as shown in the Pictorial.

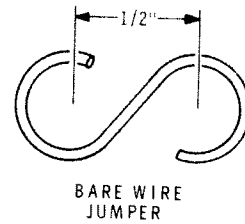

BARE WIRE JUMPER

Detail 38D

120-240 VOLT WIRING

This Amplifier can be operated from 120. or 240 volts, 50/60 Hertz, alternating current. If 240 volts can be made available, its use is recommended.

Detail 38D shows the bare wire jumpers to be used on the 6-screw terminal strip for the two supply voltages.

(X) Refer to Detail 38D and form one jumper for 240 volts or two jumpers for 120 volts.

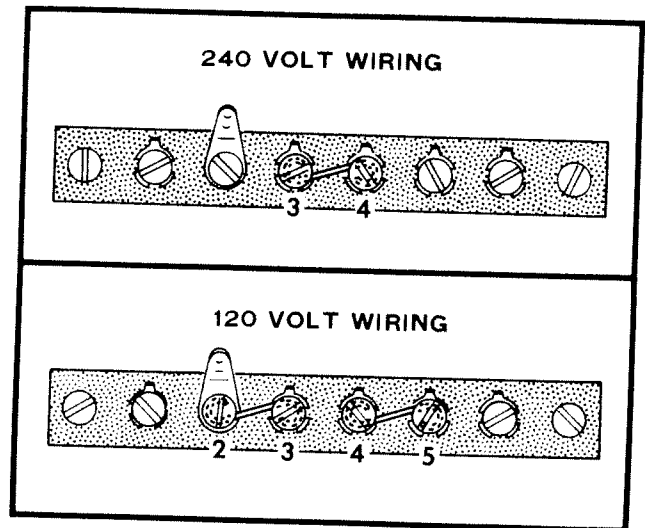

Detail 38E

Refer to Detail 38E and perform only one of the following two steps.

(X) For 240 VAC operation, connect one jumper between screws 3 and 4.

() For 120 VAC operation, connect one jumper between screws 2 and 3 and a second jumper between screws 4 and 5. Make sure all screws on the terminal strip are well tightened.

This completes the wiring of your Linear Amplifier.

CAUTION

Use extreme care during initial testing and all subsequent operation of this Linear Amplifier. While the **SB-230** is designed for maximum safety, never lose respect for the high voltage present in this unit. Protect yourself always against lethal or severe electric shock.

HEATH COMPANY

TESTS AND FINAL ASSEMBLY

Refer to Pictorial 39 (fold-out from Page 89) for the following steps.

- () Install a cabinet retainer strip on the left side panel at holes FJ and FK. Use a 10-32 x 1/2" truss head screw and two 3/4" O.D. flat washers at each hole. Position the brushed aluminum side of the retainer strip on the outside (away from the cabinet).
- () Install the other cabinet retainer strip on the right side of the RF enclosure at holes AM and AP. Use a 10-32 x 1/2" truss head and two 3/4" O.D. flat washers at each hole.

Perform only one of the following two steps, depending upon how you want your amplifier cabinet positioned.

- () If you want your amplifier to sit level, install a rubber foot at each corner of the bottom shell. For each foot, use 6-32 x 1/2" hardware.
- () If you want the front of the cabinet elevated, refer to Detail 39A and install rubber feet at holes EU and EX. Use 6-32 x 1/2" hardware. Install a rubber foot and a black tapered foot at each of holes EY and EZ. Use 6-32 x 1-1/2" hardware.
- () Install the bottom cabinet shell on the chassis. Insert the edge of the shell between the cabinet retainer strips and the flat washers. The rear edge of the shell should be flush with the rear panel.

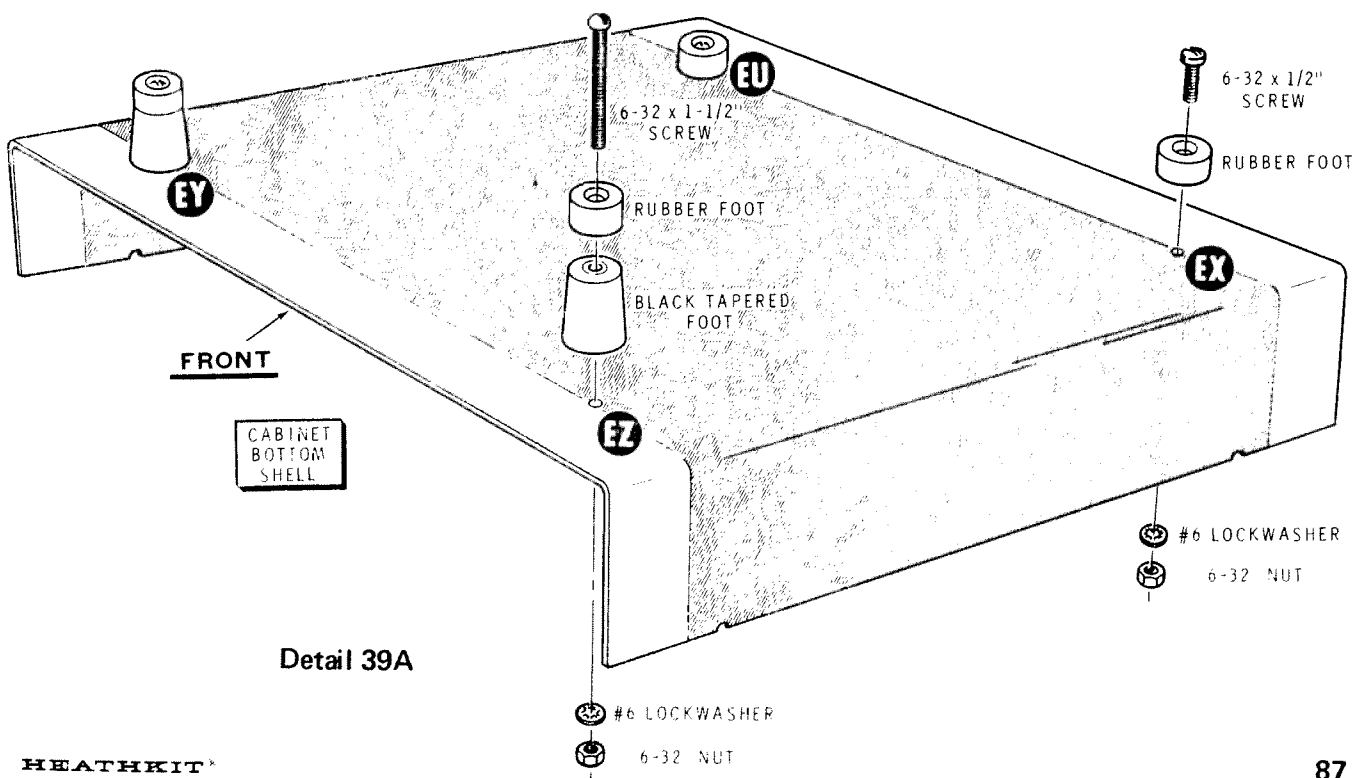



METER ZERO:

- () With the POWER switch OFF and no drive to the amplifier, turn the screw in the hole just below the meter until the meter needle rests on zero.

If you do not obtain the proper results, as described in the following steps, refer to the "In Case of Difficulty" section of this Manual.

CHECK NUMBER 1

If you have an ohmmeter available, make the following resistance checks to make sure the power supply wiring is not short circuited. If you do not have an ohmmeter, proceed to "Check Number 2." Read the meter after the needle stabilizes.

<u>CHASSIS TO 6-SCREW TERMINAL STRIP*</u>	<u>EXPECTED READING</u>
Screw 1	∞ (infinity)
Screw 2	∞ (infinity)
Screw 6	∞ (infinity)
Chassis to large blue wire (pin B) on rectifier circuit board.	Over 450 k Ω

CHECK NUMBER 2

- () Pull the connector on the white-red wire from pin 3 on the lamp indicator circuit board. Wrap tape around the connector to insulate it temporarily.
- () Refer to Pictorial 39 (fold-out from Page 89) and temporarily install the top cover on the Amplifier. As both covers are now installed, both interlock switches are closed and power can be turned on.
- () With the POWER switch OFF and the METER switch in the PLATE position, connect the line cord to your electric outlet.

- () Push the POWER switch to ON. If the needle moves up-scale, shut the Amplifier OFF immediately and refer to the "In Case of Difficulty" section. If the meter properly remains at 0, the HI TEMP lamp should light. If the POWER switch opens immediately after you push the switch to ON, refer to the note under "Power Considerations" on Page 89.

- () Turn the Amplifier off and remove the line cord from the electric outlet.

- () Remove the amplifier top cover and reinstall the white-red wire connector on pin 3 of the lamp indicator circuit board.

- () Reinstall the top cover on the Amplifier and tighten the four screws on the sides.

- () Plug in the line cord and turn the Amplifier on. The meter lamp and the DELAY lamp should light. The DELAY lamp should turn off automatically within 60 to 90 seconds.

- () Turn the METER switch to EXCITER only. The EXCITER lamp should light. When the METER switch is turned to any other position, the EXCITER lamp should turn off.

- () With the DELAY lamp off and the METER switch at PLATE, use a piece of hookup wire to simultaneously touch the chassis and the center terminal of the RELAY phono socket:

1. The relay, RY1 should close for the duration of the connection. If the relay does not close, check to see that diode D17 (across the relay terminals) has been installed with its banded end toward the rear panel.
2. The needle of the meter should move up scale and rest between 0 and 1 on the upper scale. This reading represents the zero signal (resting) plate current of about 22 mA.

This completes the "Tests and Final Assembly." Proceed to the Installation section.

*DO NOT count the mounting screws.

INSTALLATION

LOCATION

The Amplifier should not be operated in excessively warm locations or near heating vents or radiators. Air should circulate freely around and through the amplifier cabinet, and unobstructed air circulation should be provided around the heat sink. No books, magazines, or equipment should be placed on top of the cabinet to impede the free flow of air. No curtains, draperies, or combustible material should touch the heat sink.

If the Amplifier is to be placed on a piece of furniture with a fine finish and operated in a continuous duty mode, such as RTTY or SSTV, a protective covering should be placed under the amplifier heat sink and rear feet to prevent any heat damage.

POWER CONSIDERATIONS

Because of the power involved, this Amplifier should preferably be served by its own 240 VAC electric service line. The power cord furnished is designed for a standard 120 VAC electrical outlet. If you have a 240 VAC outlet, the plug must be changed. If you will install a new 240 VAC outlet, check your local electrical code, as it is essential that you use an outlet and plug designed for this service. Keep in mind that the green line cord wire is connected to the amplifier chassis.

If only 120 VAC can be provided, a separate line to the Amplifier is desirable.

NOTE: If you operate your amplifier from a 120 VAC line, the power surge may cause the POWER switch to open whenever it is pushed to the ON position. If this happens, push the POWER switch ON again. However, if the switch opens a second time, this is abnormal and you should refer to the "In Case of Difficulty" section of this Manual.

DO NOT use this Amplifier at its full ratings on a regular house wiring circuit, to which other loads are connected, as the ratings of the wire will almost certainly be exceeded.

Avoid excessively long runs of wire from your service entrance. A heavy flow of current in such a line results in a voltage drop which can affect the performance of your equipment.

The POWER switch and circuit breaker are connected to the black (hot) line cord wire. The green (neutral) line cord wire is connected to the amplifier chassis.

ANTENNA

The output circuit of the Amplifier is designed for connection to an unbalanced transmission line of 50 Ω characteristic impedance. Lines of other characteristic impedance may be used providing the SWR (standing wave ratio) does not exceed 2:1.

The antenna connector is a UHF type SO-239. A mating PL-259 plug is furnished for your transmission line. RG-8/U or RG-11/U, coaxial cables or similar types, are recommended for the transmission line. The smaller types, RG-58/U and RG-59/U, are not recommended because of the power level. An adapter for these smaller cables is included in your kit if the recommended cables are not used.

The "ARRL Antenna Book" is commonly available and includes comprehensive reference work on transmission lines and antennas. Other similar handbooks for the amateur are offered for sale and can often be found in a public library.

GROUNDING

A good earth or water pipe ground should be connected to the ground post on the rear apron of the Amplifier. Use the heaviest and shortest connection possible.

Before using a water pipe ground, inspect the connections

around your water meter and make sure that no plastic or rubber hose connections are used which interrupt electrical continuity to the water supply line. Install a jumper around any insulating water connectors found. Use heavy copper wire and pipe clamps. It is best to ground all equipment to one point at the operating position and then ground this point as discussed above.

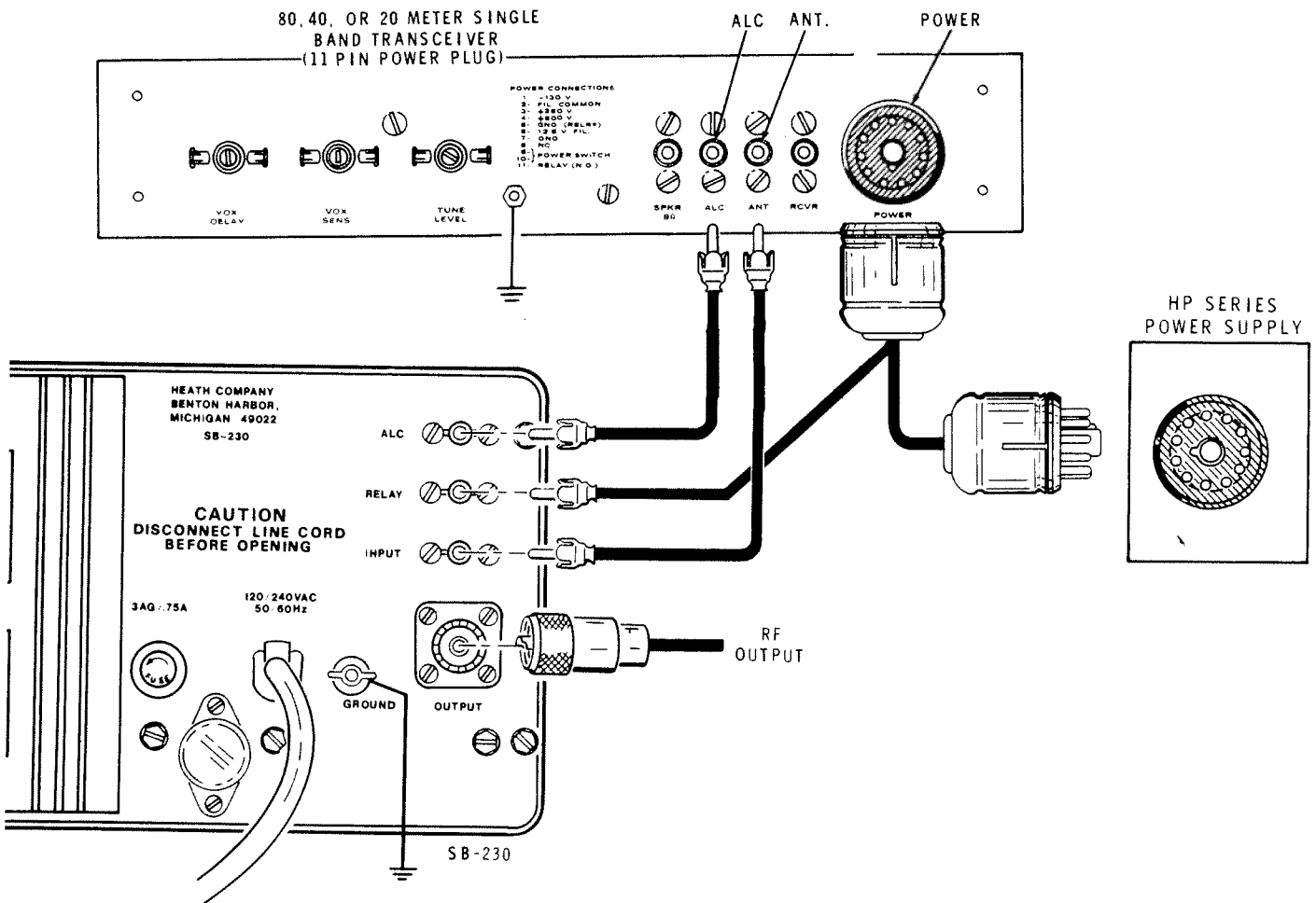

Figure 1-4

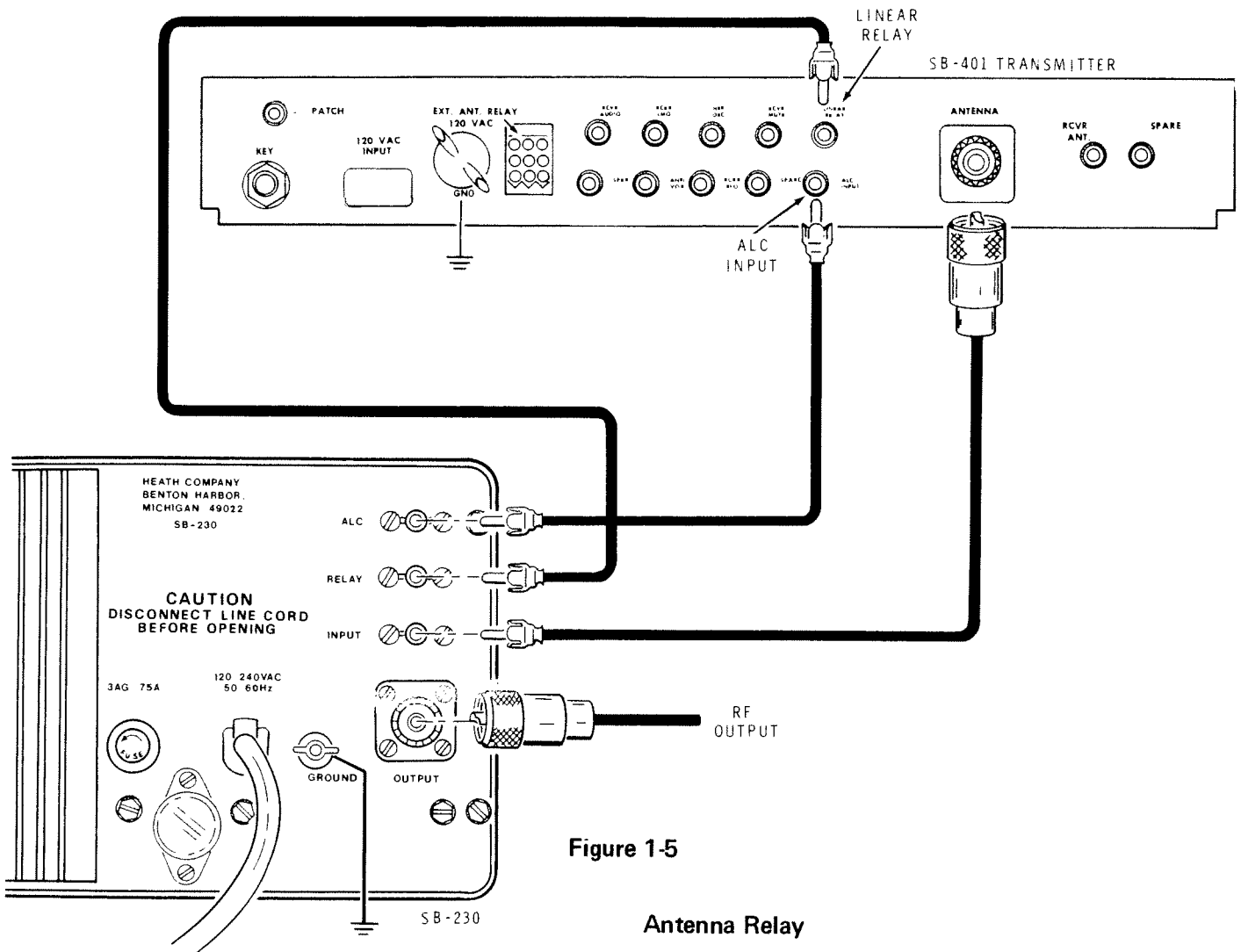

Figure 1-5

Antenna Relay

OPERATION

The RELAY socket on the rear panel of the Amplifier must be connected to ground in the transmit mode. Heath excitors contain a provision to accomplish this action. If a relay terminal, or other switching provision is not available, this function must be provided by other means. If a separate coaxial send-receive relay is used in your station, it may have external contacts available (see Figure 1-6). A separate switch can also be used.

EQUIPMENT INTERCONNECTIONS

Interconnections between this Amplifier and other Heath equipment are shown in the Figure 1 series of illustrations on fold-outs from Pages 90 and 91. Other makes of equipment will usually follow the same general pattern.

OPERATION

CONTROL FUNCTIONS

Refer to Figure 3 (fold-out from Page 92) to identify the front panel controls and to Figure 4 (fold-out from Page 97) for rear panel connectors.

RELATIVE POWER SENSITIVITY (R34):

When the METER switch is at EXCITER ONLY or at REL PWR (relative power), this control should be adjusted for full-scale meter deflection with single tone input (exciter at Tune or key-down CW). The meter will thereafter indicate output power relative to the power level used to establish the full-scale setting.

When this switch is at EXCITER ONLY, the meter will show the relative output power of the exciter; when it is at REL PWR, the meter will show the total amplifier relative power output.

METER (M1):

Indicates Relative Power, Plate current, Grid current, or High Voltage. See "Reading the Meter."

TUNE (C12):

The input variable capacitor for the pi network tank circuit. When the METER switch is at REL PWR, this control can be adjusted for maximum meter deflection; when the METER switch is at PLATE, it can be adjusted for the dip in plate current.

BAND (SW3):

The BAND switch. Selects the amateur band desired.

LOAD (C15):

Adjusts the output of the pi network plate tank circuit for best impedance match and maximum power transfer to the output line.

POWER SWITCH and CIRCUIT BREAKER (SW1):

The rocker POWER switch turns your Amplifier ON and OFF. It also contains a built-in circuit breaker to protect the power transformer from overloads.

After the POWER switch has been pushed ON, if you hear a click and the panel lights are extinguished, the circuit breaker has probably opened due to an overload. Wait a few seconds and push the switch to ON. If the circuit breaker will not permit the POWER switch to remain ON, it is probable that a continuing overload or a short circuit exists. This condition must be cleared before normal operation can proceed.

LAMP INDICATORS

Meter Lamp (PL1):

This lamp illuminates the meter scale whenever the amplifier is ON.

Hi Temp (PL4):

If the amplifier tube causes the heat sink to exceed a predetermined temperature, the thermal circuit breaker (TC1 on the schematic) will open and cause the HI TEMP lamp to turn on. When this occurs, the amplifier tube will be biased to cut-off and the transmit-receive relay will open to return the input and output circuits to the exciter only mode. The Amplifier can be used again when the heat sink cools down; at which time the HI TEMP lamp will turn off.

In normal operation, you probably will never see this lamp turned on.

Exciter (PL2):

This lamp is turned on when the METER switch is at EXCITER ONLY. It indicates that the Amplifier's input is connected directly to its output and that the Amplifier is out of the circuit. This mode is useful when you want to operate with your exciter only, but you also want the Amplifier warmed up so it can be switched on instantaneously.

Should you wish to change bands after the Amplifier has been warmed up, switch to EXCITER ONLY while you tune up your exciter on the new band; then you can switch to REL PWR and follow the amplifier tune-up procedure for the new band.

When your Amplifier is not turned on, it is automatically in the EXCITER ONLY mode.

Delay (PL3):

This lamp is lighted when the Amplifier is initially turned ON. It is controlled by the time delay relay (RY2) and will remain ON for 60 to 90 seconds, during which time the tube warms up and the Amplifier cannot be operated (except in EXCITER ONLY mode).

If the Amplifier has been turned OFF only momentarily (as during a temporary overload), the delay lamp may not turn on when the POWER switch is pushed ON. This indicates that you can resume normal Amplifier operation without delay.

RELAY (RY1):

When this connection is grounded, the transmit-receive relay in the Amplifier operates and places the Amplifier in the transmit mode. Connect this socket to your exciter antenna relay input or to a pair of spare relay contacts (or a separate switch) which will ground this circuit when your exciter is in the Transmit mode. This connection will not function when the METER switch is at EXCITER ONLY.

INPUT:

Connect to the output of your exciter with coaxial cable (RG-58/U or RG-8/U recommended).

OUTPUT:

Connect to your transmission line, antenna coupler, monitorscope, or other device, with coaxial cable (RG-8/U or RG-11/U recommended).

FUSE (F1):

Fuse in the drive line to the cathode of the amplifier tube. Where required, replace with a type 3AG, .75 ampere, slow-blow fuse.

GROUND POST:

Connect to your station ground system.

READING THE METER

Refer to Figure 5 for an illustration of the panel meter scale. The upper scale of the meter reads from 0 to 8 and the lower scale from 0 to 3. The METER switch on the front panel selects the circuit function to be measured as detailed in Figure 6.

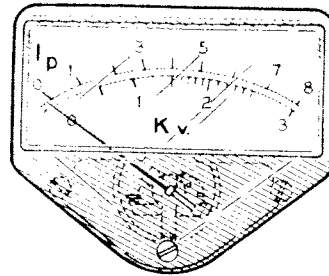

Figure 5

METER SWITCH POSITION	MEASURES	SCALE READING
EXCITER ONLY	Relative power output of exciter.	0 – 8 (upper scale). Adjust needle deflection to full scale with REL PWR SENS control after tune-up.
REL PWR	Relative power output of amplifier.	
PLATE	Plate current	0 – 800 mA (upper scale).
GRID	Grid current	0 – 80 mA (upper scale).
HV	High voltage	0 – 3 (3000 volts lower scale).

Figure 6

DRIVING POWER

This Amplifier is designed to operate at full ratings when it is used with the usual "100 watt" exciter, which will drive it to the currents specified in the tune-up procedures. An exciter of lower power output may be used as a driver, but the amplifier's output will be less. If you use an exciter capable of higher power, carefully adjust the exciter gain control (driving power) to avoid "overdrive" and the creation of spurious signals which create needless

interference to others. The use of the Heathkit Monitor Scope is highly recommended for continuous output monitoring (see Figures 7, 8 and 9). The display on an oscilloscope is the best readily available way of determining the amplitude of the voice peaks which, if excessive, can cause "flat topping" and the radiation of distortion products.

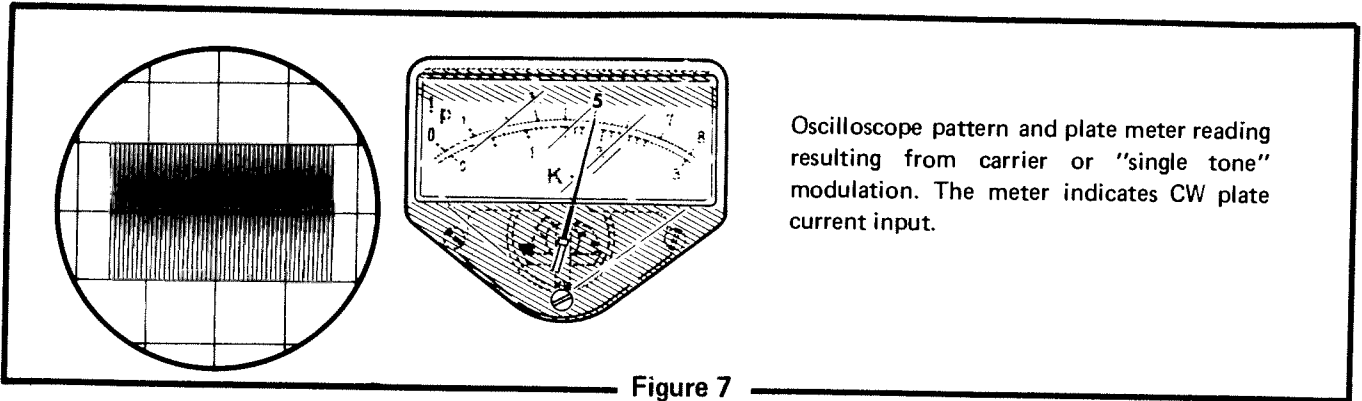

Figure 7

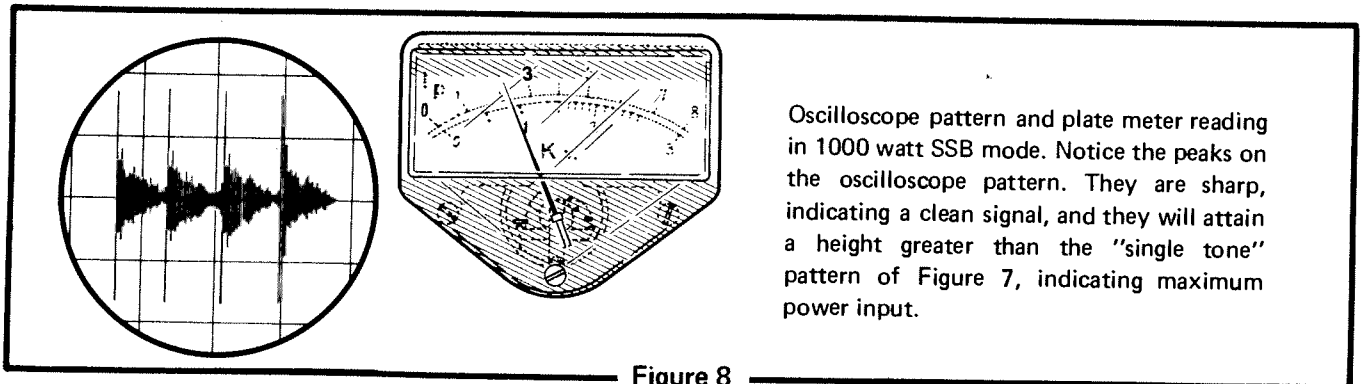

Figure 8

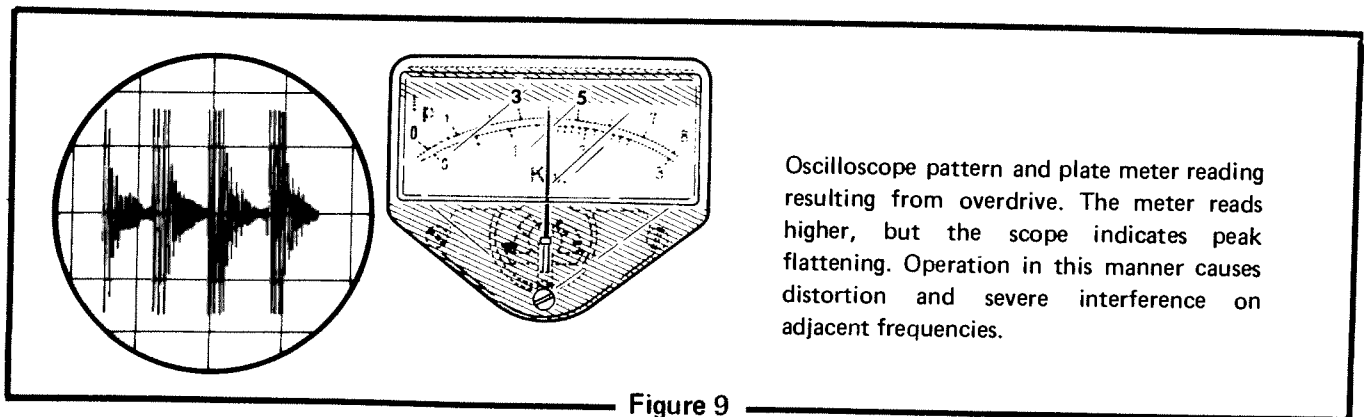

Figure 9

IMPORTANT: In no case should the gain control of your exciter be advanced beyond the point where the amplifier relative power indication ceases to increase. If the level control is turned past this point, nonlinear operation may be produced.

ALC (Automatic Level Control)

When the Amplifier is overdriven, the ALC circuitry creates a negative voltage which is fed back to the exciter to reduce its gain and help prevent "flat topping". Protective circuitry

of this nature is a valuable aid, but it is NOT a substitute for proper adjustment of the exciter drive.

DC INPUT POWER

In grounded grid amplifier operation, a considerable portion of the driving power is fed through the amplifier tube. The amplifier output is the approximate sum of the driver output and the power added by the Amplifier. Both the driver and amplifier input powers must therefore be considered when calculating DC input power.

TUNE-UP

MAXIMUM CURRENT RATINGS			NO LOAD VOLTS
MODE	PLATE	GRID	PLATE
CW, SSB	500 mA*	30 to 40 mA	2500 (120 VAC line)
RTTY, SSTV	200 mA	5 mA	

*In SSB mode, with voice modulation, the plate current meter indication on voice peaks will be 175 mA to 250 mA, depending upon the voice characteristics of the operator. This current indication is due to the inability of a meter to follow instantaneous voice peaks.

Figure 10

The current and voltage figures given in Figure 10 are approximations. Actual readings will vary at each installation with such factors as line voltage, exciter drive, and load impedance.

The following procedure for tuning the Amplifier should take only a few seconds after you go through it a few times. Note the LOAD control position so it can be preset the next time a particular band is used.

4. The ALC socket has been connected back to your exciter's ALC input.
5. The Amplifier has been connected to your station's ground system.
6. The Amplifier's line cord is plugged in.

Before proceeding, make sure that:

1. OUTPUT on the rear panel is connected to an antenna for the band to be used, or to a dummy load.
2. Your exciter output is connected to the amplifier INPUT.
3. Provision has been made to ground the RELAY connector in the transmit mode so the amplifier transmit-receive relay will operate.

IMPORTANT:

1. During the tune-up procedure, DO NOT furnish excitation to the Amplifier for more than 30 seconds continuously. This requirement is fulfilled by turning your exciter's gain control fully counterclockwise between adjustments.
2. During tune-up, be SURE to observe the duty cycle limitations, if any, of your exciter.



CW or SSB PROCEDURE

NOTE: For this explanation, a Heathkit Model SB-104 Transceiver is used as a driver. Other exciters should follow the same principles.

- () Preset your amplifier controls as follows:

REL PWR SENS:	12 o'clock (straight up)
METER switch:	EXCITER ONLY
TUNE:	Appropriate band segment
BAND:	Amateur band desired
LOAD:	9 o'clock (1 on scale)
POWER:	OFF

- () Push the POWER switch to ON. The meter, DELAY, and EXCITER lamps should turn on.
- () Tune your exciter for maximum output in the desired mode while the Amplifier warms up.
- () With the exciter at full output in either the tune or CW mode, adjust the REL PWR SENS control on the Amplifier so the meter reads 2 on its upper scale. Then turn the exciter gain down.
- () When the DELAY lamp turns off (after 60 to 90 seconds), turn the METER switch to PLATE and advance the exciter gain until the Amplifier's meter reads 100 mA (1 on the upper scale).
- () Quickly turn the METER switch to REL PWR and adjust the amplifier's TUNE control for maximum meter deflection. Then release the exciter's TUNE button.
- () After a few seconds, turn the METER switch to PLATE and depress the exciter's TUNE button. Advance the exciter's gain for a meter reading of 200 mA (2 on the upper scale).
- () Quickly turn the METER switch to REL PWR and adjust the LOAD control for maximum meter deflection. Then release the exciter's TUNE button.
- () After a few seconds, turn the METER switch to PLATE and depress the exciter's TUNE button. Advance the exciter's gain for a meter reading of 400 mA.
- () Quickly turn the METER switch to REL PWR and touch up the TUNE and LOAD controls for maximum meter deflection.
- () Turn the METER switch back to PLATE and adjust the exciter's gain for a meter reading of 500 mA (or less). Then release the exciter's TUNE button.
- () After a few seconds (at the same drive level) check your plate and grid currents. If the plate current is higher than 500 mA (maximum rated input), reduce your exciter's gain. The grid current should be 40 mA or less. If it is higher, go through the tuning procedure again to make sure the Amplifier is properly tuned and loaded. If the grid current is still over 40 mA, reduce the exciter's gain until that reading is reached. Then

return your exciter to the standby mode, without changing the gain control.

() At the same gain control setting as in the preceding step, and with the METER switch at REL PWR, return your exciter to the tune or CW mode. Then adjust the REL PWR SENS control for a full-scale amplifier meter deflection.

() Return the exciter to the receive mode.

This completes the SSB or CW tune-up procedure.

RTTY or SSTV PROCEDURE

() Preset your amplifier controls as follows:

REL PWR SENS:	12 o'clock (straight up)
METER switch:	EXCITER ONLY
TUNE:	Appropriate band segment
BAND:	Amateur band desired
LOAD:	9 o'clock (1 on scale)
POWER:	OFF

() Push the POWER switch to ON. The meter, DELAY and EXCITER lamps should turn on.

() Tune your exciter for maximum output in the desired mode while the Amplifier warms up.

() With the exciter at full output in either the tune or CW mode, adjust the REL PWR SENS control on the

Amplifier so the meter reads 2 on its upper scale. Then turn the exciter gain down.

() When the DELAY lamp turns off (after 60 to 90 seconds), turn the METER switch to PLATE and advance the exciter gain until the Amplifier's meter reads 100 mA (1 on the upper scale).

() Quickly turn the METER switch to REL PWR and adjust the TUNE control for full scale meter deflection. Then reduce your exciter's gain.

() After a few seconds, turn the METER switch to PLATE and advance the exciter's gain for a meter reading of 200 mA (2 on the upper scale).

() Quickly turn the METER switch to REL PWR and adjust the LOAD control for maximum meter deflection. Then reduce the exciter's gain.

() After a few seconds (at the same drive level as in the preceding step) check your plate and grid currents. If the plate current is higher than 200 mA, reduce your exciter gain. The grid current should be 5 mA or less. If it is higher, go through the tuning procedure again to make sure the Amplifier is properly tuned and loaded. If the grid current is still over 5 mA, reduce the exciter gain until that reading is secured. Then return your exciter to the receive mode.

This completes the RTTY or SSTV tuning procedure.



IN CASE OF DIFFICULTY

CAUTIONS:

1. If you have occasion to remove the amplifier tube from its socket during your search for difficulty, be SURE to first read the paragraph in this section entitled "Beryllium Oxide Ceramic Block."
2. Before touching any part of the amplifier interior, ALWAYS:
 - A. DISCONNECT the line cord.
 - B. Wait one minute and then DISCHARGE the power supply filter capacitors by touching a screwdriver simultaneously to the chassis and to the foil at B on the rectifier circuit board (to which the large blue wire is connected).

1. Be sure you have performed "Tests and Final Assembly" on Page 87.
 2. Recheck the wiring. Trace each lead in colored pencil on the Pictorial as it is checked. It is frequently helpful to have a friend check your work. Someone who is not familiar with the unit may notice something consistently overlooked by the constructor.
 3. The majority of the kits that are returned for repair, do not function properly due to poor connections and soldering. Many troubles can be eliminated by carefully reheating all connections to make sure that they are soldered as described in the Soldering section of the "Kit Builders Guide."
 4. Check the values of the parts. Be sure that the proper part has been wired into the circuit as shown in the Pictorial Diagrams and as called for in the wiring instructions.
 5. Check for bits of solder, wire ends, or other foreign matter which may be lodged in the wiring.
 6. Check for continuity between amplifier tube pins 5 and 6 with an ohmmeter. An infinite resistance will indicate a faulty tube filament. Also check from the grid (pins 4, 7, 11) to the cathode (pins 1, 2, 3, 8, 9, 10) and to the tube plate for a short circuit. If you feel the tube is faulty, refer to "Technical Consultation" on the inside, rear cover of your Manual.
 7. A review of the "Circuit Description" may also help you locate the trouble.
- NOTE: In an extreme case where you are unable to resolve a difficulty, refer to the "Customer Service" information inside the rear cover of this Manual.

BERYLLIUM OXIDE CERAMIC BLOCK

CAUTION:

Dust and fumes of Beryllium Oxide are DEADLY POISONOUS and should not be inhaled or brought into contact with the skin or eyes.

Do not perform any dust-producing operations (drilling, chipping, crushing, sawing, or filing) on the block.

Do not heat it over 1,000°C (unit operation will not exceed 400°C).

Wash hands after handling.

If it is dropped, remove any chips and dust with a wet towel, which should be discarded in a sealed plastic bag – do not sweep or vacuum.

For hygiene information, consult Page 4 of this Manual or write to the Heath Company.

TROUBLESHOOTING CHART

DIFFICULTY	POSSIBLE CAUSE
1. No meter light. <div style="text-align: center; font-size: 2em; font-family: cursive;">OK</div>	A. PL1. B. SW1. C. Open connection. D. Lamp burned out.
2. No Delay light. <div style="text-align: center; font-size: 2em; font-family: cursive;">OK</div>	A. PL3. B. V1 grid circuit shorted. C. Q1. D. RY2. E. TC open. F. D16.
3. No Exciter Only light. <div style="text-align: center; font-size: 2em; font-family: cursive;">OK</div>	A. PL2. B. SW2. C. D16.
4. HI Temp light on improperly.	A. TC. B. Q2.
5. No plate current.	A. F1. B. ZD1.
6. High plate current.	A. Short in cathode line. B. ZD1 terminals shorted. C. ZD1 internally shorted.
7. SW1 circuit breaker opens.	A. Internal short in T1. B. High voltage B+ line shorted. C. Primary circuit shorted. D. Secondary circuits overloaded.
8. Send-receive relay operates improperly.	A. Relay circuit shorted. B. Switch wiring error. C. Exciter relay line grounded. D. D17 open, shorted, or installed backward. E. Grid strap shorted.
9. High voltage low.	A. Rectifier diode open. B. Filter capacitor open or shorted. C. Low voltage circuit shorted. D. Low line voltage.
10. No relative power output indicated.	A. No power output. B. D18. C. R34.
11. High uncontrollable plate and grid current.	A. Grid circuit shorted. B. Feedthrough capacitor open, shorted, damaged, or poorly soldered to chassis. C. Poor ground (tighten all hardware in the RF enclosure).

SPECIFICATIONS

Band Coverage	80, 40, 20, 15, and 10 meter amateur bands.
Maximum Power Input	SSB: 1200 watts P.E.P. CW: 1000 watts @ 50% duty cycle.
Duty Cycle	SSB: Continuous voice modulation. CW: Continuous (maximum key-down time, 30 seconds). RTTY/SSTV: 50% maximum transmit time.
Driving Power Required	Less than 100 watts.
Third Order Distortion	-30 dB or better
Output Impedance	50 – 75 ohms at SWR 2:1 or less.
Input	52 Ω at less than 1.5:1 SWR.
Meter Switch	Exciter only. Relative power. Plate current. Grid current. High voltage.
Front Panel	Load. Tune. Band. Relative power sensitivity. Power switch. Meter switch.
Rear Panel	ALC output. Exciter relay. RF input. RF output. Ground lug. Fuse. Line cord.



Tube	Type 8873.
Zero-Signal Plate Current	22 mA at approximately 2400 volts.
Power Requirements	120 volts AC, 50/60 Hz, at 14 amperes (peak). 240 volts AC, 50/60 Hz, at 7 amperes (peak).
Cabinet Size	14-3/4" wide, 16" deep, 7" high maximum.
Net Weight	33.5 lbs.

The Heath Company reserves the right to discontinue products and to change specifications at any time without incurring any obligation to incorporate new features in products previously sold.

CIRCUIT DESCRIPTION

POWER SUPPLY

The power supply transformer has dual primary windings and may be connected for either 120 or 240 volt AC operation. The pilot lamp is connected across one-half of the primary winding so it will always have a 120 volt AC source. The transformer is protected against overload by a circuit breaker which is part of the Power switch SW1.

One secondary winding of the power transformer is used with silicon diodes D1 through D15 and electrolytic capacitors C3 through C8 in a full-wave, voltage-doubler circuit to provide plate voltage for the amplifier tube. Resistors R3 through R8 equalize the voltage across the electrolytic filter capacitors. These resistors also serve as a bleeder for the high voltage supply. Resistor R9 provides a means of measuring plate current independently of bleeder current.

Another secondary winding of the power transformer supplies 6.3 volts AC for the tube filament and for RY2, the time delay relay. A third secondary winding uses a half-wave rectifier circuit composed of diode D16 and a filter formed by resistor R22 and capacitor C16. This circuit provides operating voltage for RY1, the transmit-receive relay, and cutoff bias voltage for the grid of the amplifier tube.

INPUT CIRCUIT

Amplifier tube V1 is connected in a cathode-driven (grounded grid), Class AB₂ configuration. The tube filament is isolated for RF from the transformer filament winding by a bifilar-wound choke, RFC3. Driving power is coupled through capacitor C32 to the cathode of the amplifier tube. Part of this driving power is fed through the Amplifier to the output circuit.

One of the functions of R21 is to act as an impedance matching device. It is composed of fifteen 1500 ohm, 2-watt

resistors in parallel, which form a 100 ohm, 30 watt resistance. This resistance, in parallel with the tube driving impedance, causes the exciter to look into the desired 50 ohm load. Another function of R21 is to dissipate a portion of any excess driving power. The amplifier tube is easy to drive and does not require the full output of most "100 watt" exciters.

Grid-derived ALC is used. C22 and C24 form an RF voltage divider in the grid circuit. Whenever the positive peaks of this voltage exceed the threshold of diode D19, it conducts and shunts these voltages to ground. The negative voltages are filtered by R18, R19, C24, and C25 and are connected to the ALC Out socket, where they are available to reduce the gain of an exciter.

The .75 ampere fuse protects the tube from being overdriven.

OUTPUT CIRCUIT

High voltage is applied to the plate of the amplifier tube through RF choke RFC2. The inductance of the ferrite beads in the plate circuit act as parasitic chokes.

The output circuit is a pi network. C12 is the input (tuning) capacitor, L1 and L2 are the tapped inductors, and C15 is the output (loading) capacitor. Padding capacitors C13 and C14 are switched in parallel with the tuning and loading capacitors to provide an adequate amount of capacity on the 80 meter band. The output power is applied through the transmit-receive relay to the Output connector when RY1 is closed. In the receive, or Exciter Only mode, the amplifier Input connector is connected directly to the Output connector and the amplifier circuits are bypassed.

When the Meter switch is in the Exciter Only or REL PWR positions, a portion of the output signal is coupled through resistor R36, rectified by diode D18, filtered by capacitor C21, adjusted by control R34, and measured as relative power output.

The amplifier tube is in series with the driving power, so the amplifier power is added to the driving power.

RELAY AND LIGHT CIRCUITS

Available contacts on the exciter's VOX relay are connected to the Relay phono socket on the Amplifier's rear panel. When you are transmitting, the VOX relay grounds and closes RY1, the transmit-receive relay, through TC1 (the thermal circuit breaker) and RY2 (the time delay relay). It also grounds the grid of amplifier tube V1, permitting it to operate. When you are receiving, the ground for the transmit-receive relay is removed and the relay opens. The ground for the grid of tube V1 is therefore removed, which biases the tube into cut-off.

When the Amplifier is first turned on, the contacts of the time delay relay are open. These contacts will close when the filament of the relay reaches a predetermined temperature 60 to 90 seconds after turn-on, which allows ample time for the tube filament to reach operating temperature. While these contacts are still open, a voltage differential exists across RY2. This voltage is applied across transistor Q1, which turns on and furnishes a ground to the Delay lamp, PL3, which turns on. When the contacts of RY2 close, the voltage differential no longer exists and Q1 turns

off. This removes the ground from the Delay lamp, which also turns off.

When the Meter switch is in the Exciter Only position, the Exciter lamp, PL2, is turned on by voltage applied through the Meter switch contacts. The tube grid is biased off and remains in the receive mode because contacts 8 and 10 of the Meter switch are open.

If the heat sink on the Amplifier should overheat, the thermal circuit breaker will open, breaking the ground circuits of RY1 and the grid of the amplifier tube, so these components return to the receive mode. Also, when the thermal circuit breaker contacts open, a voltage differential is created across transistor Q2 which therefore turns on and furnishes a ground to HI TEMP lamp PL4, which lights. When the heat sink cools, the contacts of the thermal circuit breaker will close, the voltage differential across Q2 will be removed, and Q2 and PL4 will turn off.

METERING CIRCUITS

Simplified metering circuits are shown in Figure 11. Detailed circuit tracing can be done on the schematic diagram. Switch SW2R establishes the connections for each metering circuit.

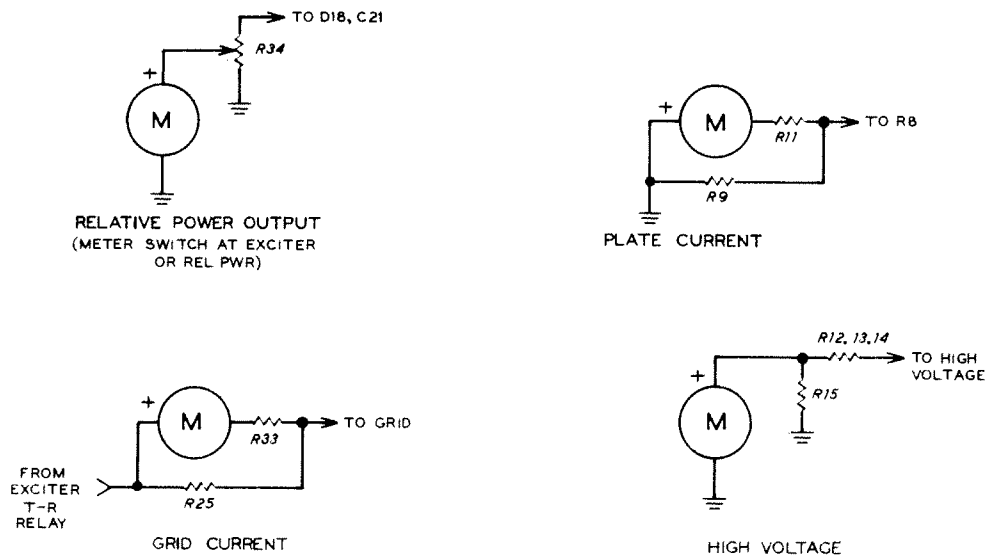
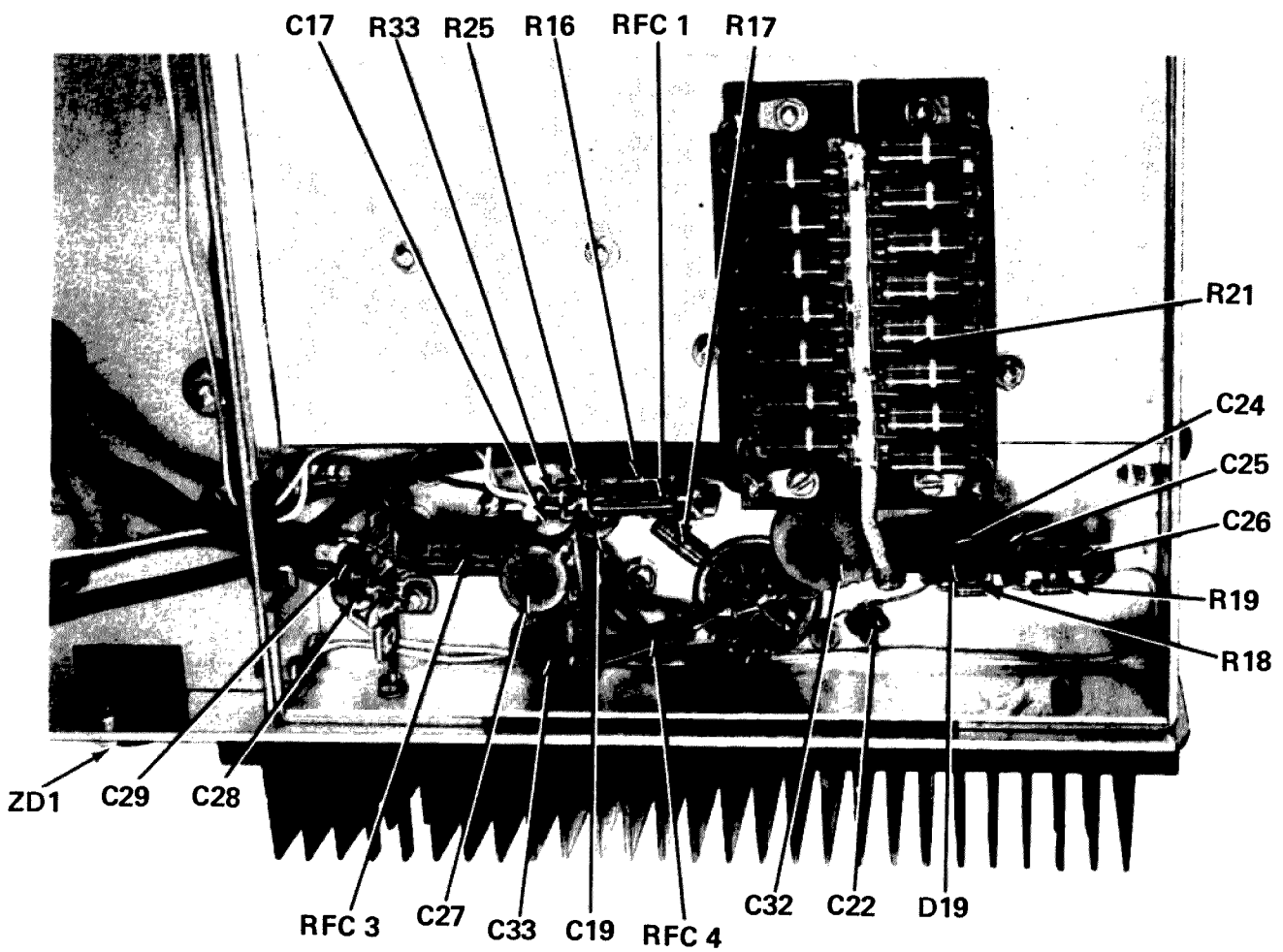
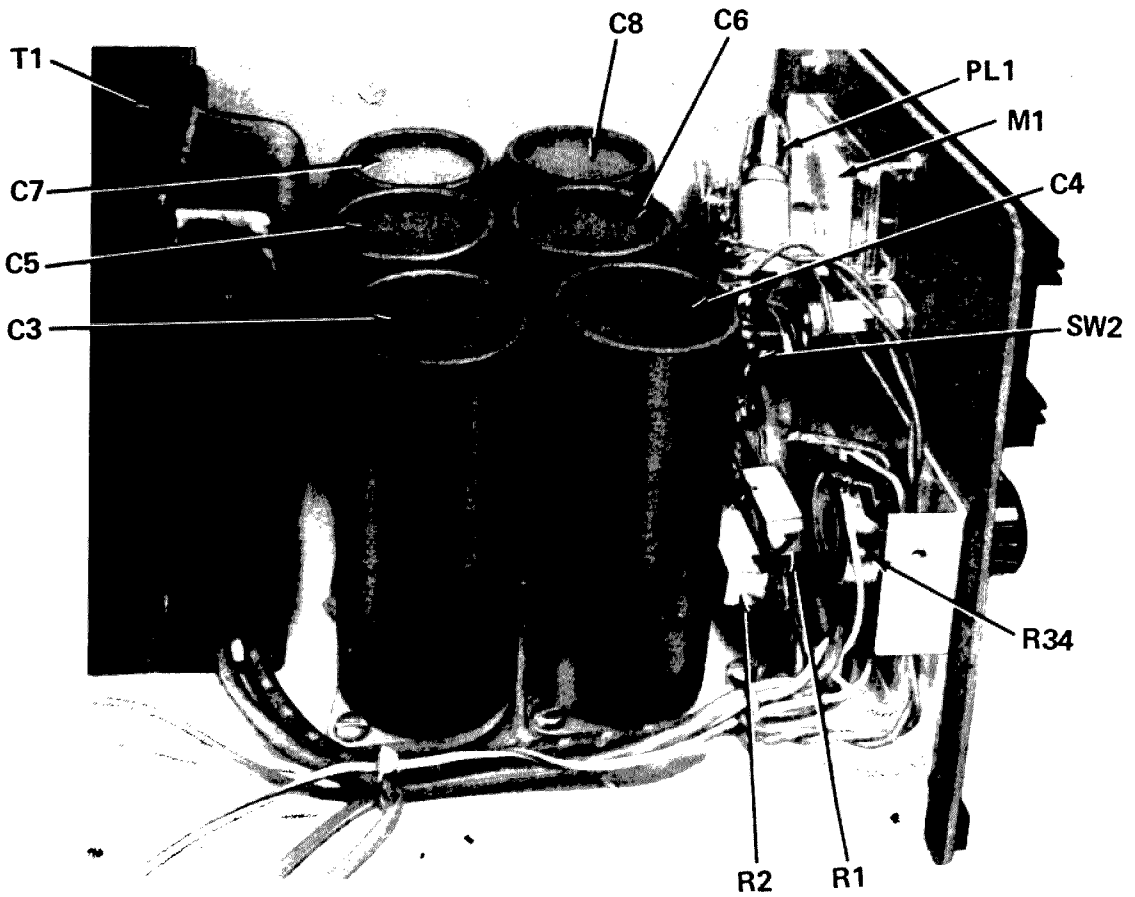
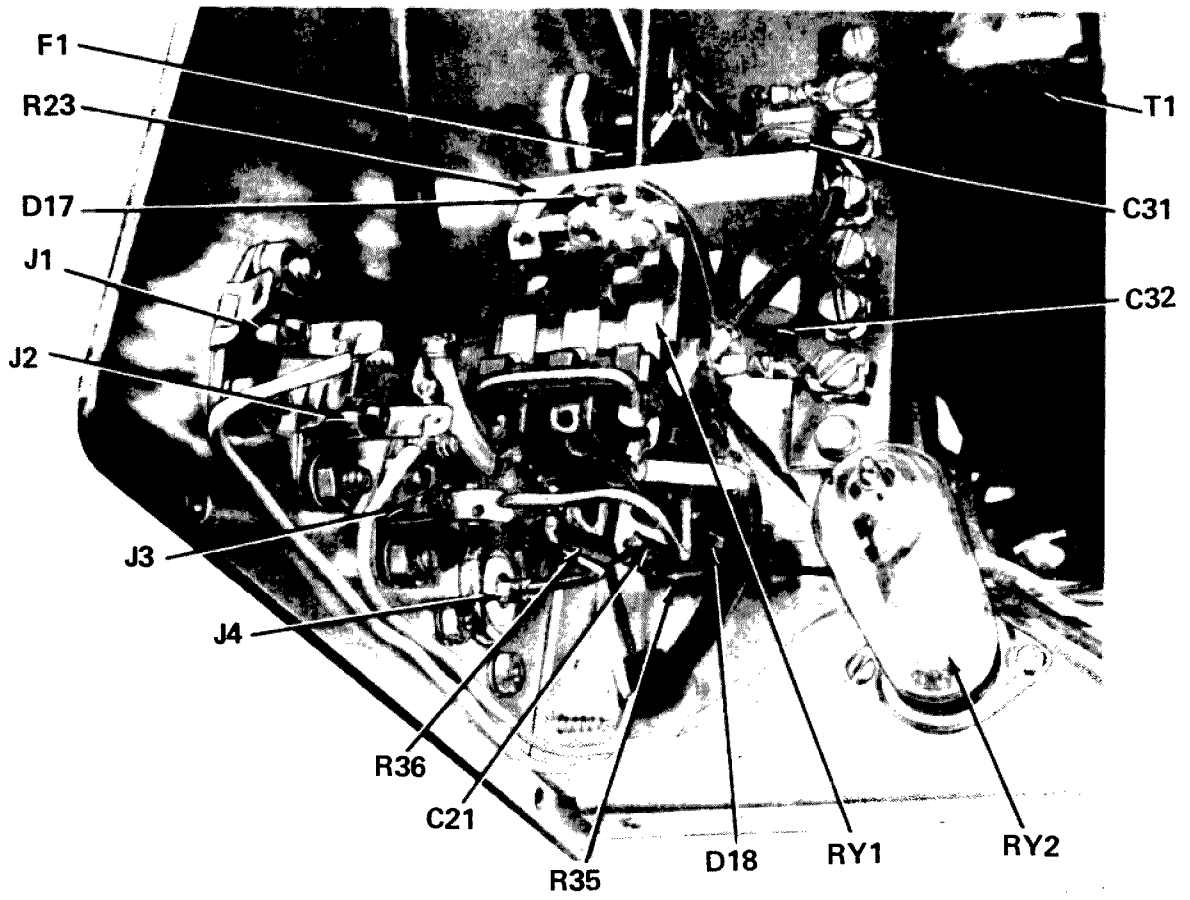
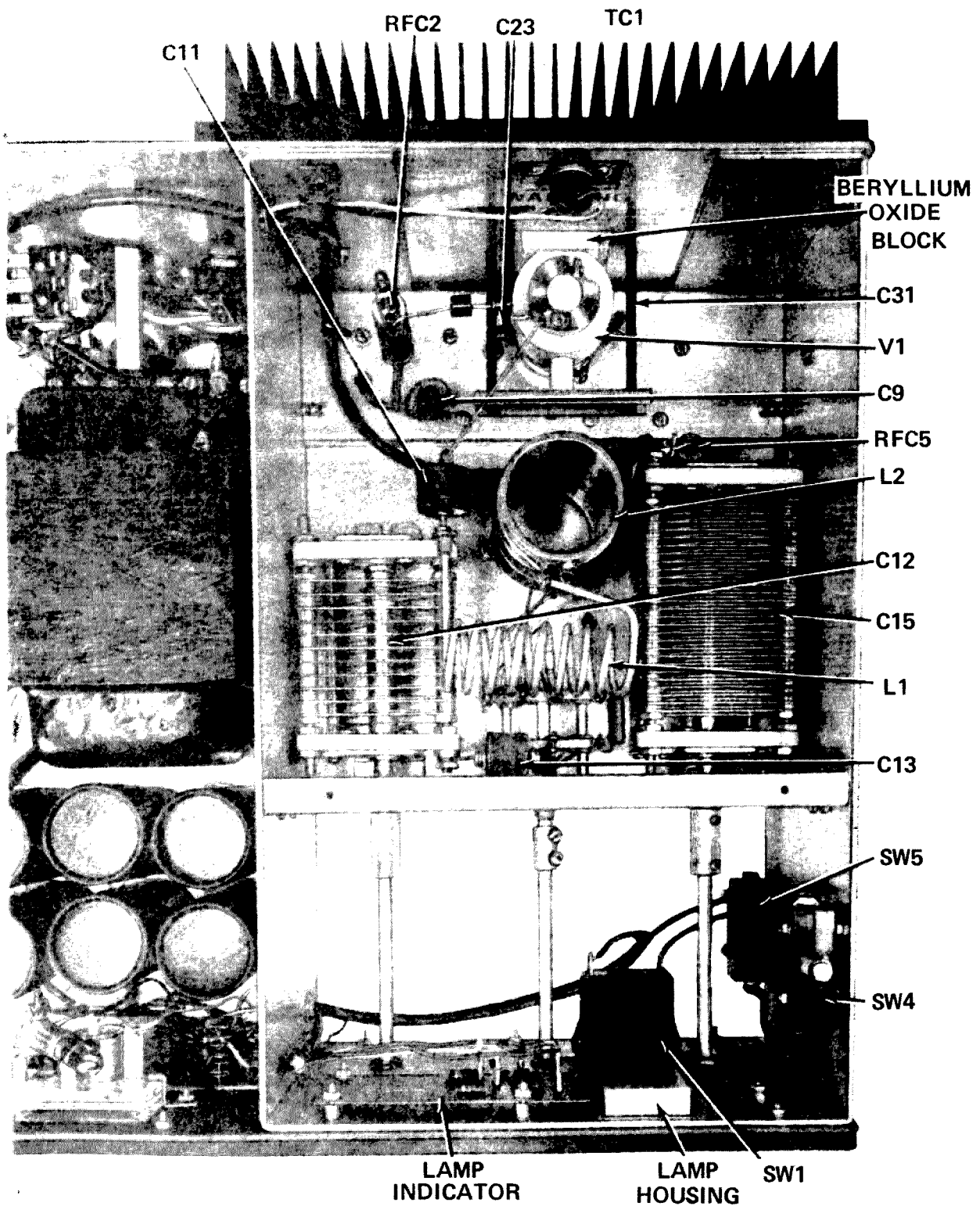

Figure 11

CHASSIS PHOTOGRAPHS







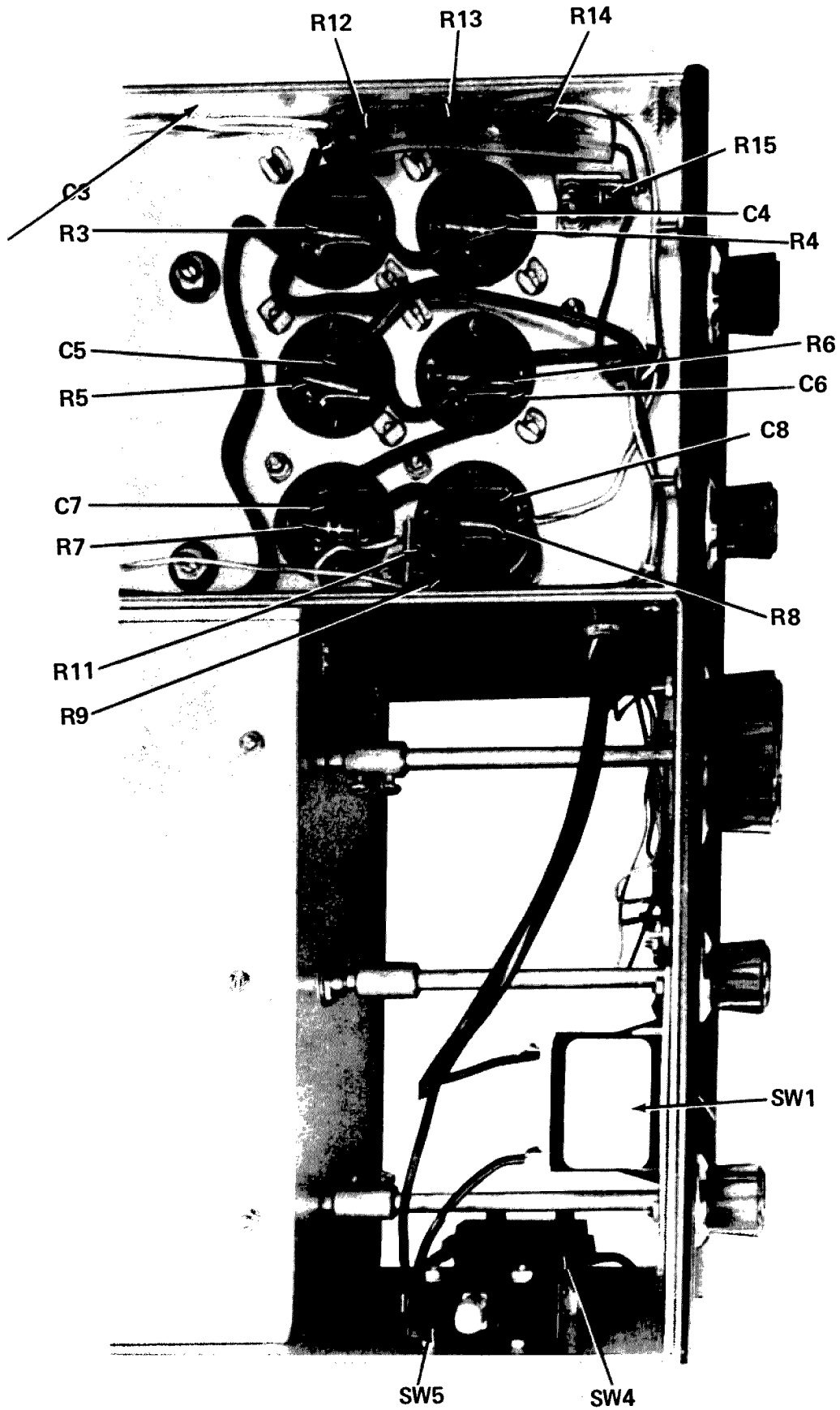

CIRCUIT BOARD X-RAY VIEWS

NOTE: To find the PART NUMBER of a component for the purpose of ordering a replacement part:

- A. Find the circuit component number (R5, C3, etc.) on the "X-Ray View" or "Chassis Photographs."
- B. Locate this same number in the "Circuit Component Number" column of the "Parts List."
- C. Adjacent to the circuit component number, you will find the PART NUMBER and DESCRIPTION which must be supplied when you order a replacement part.

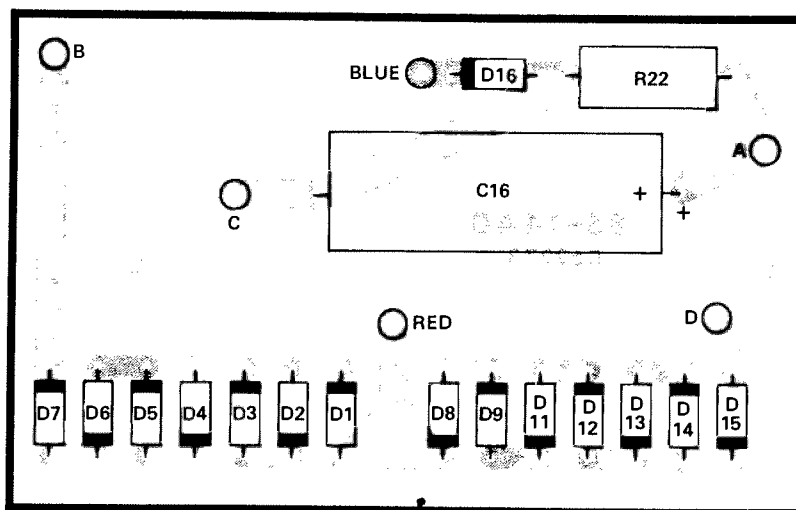

(Viewed from component side)

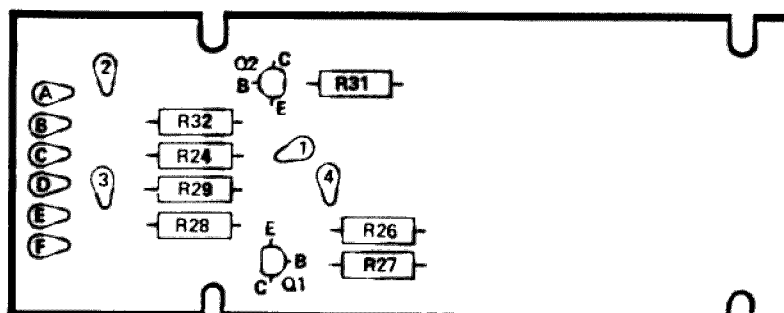

(Viewed from component side)

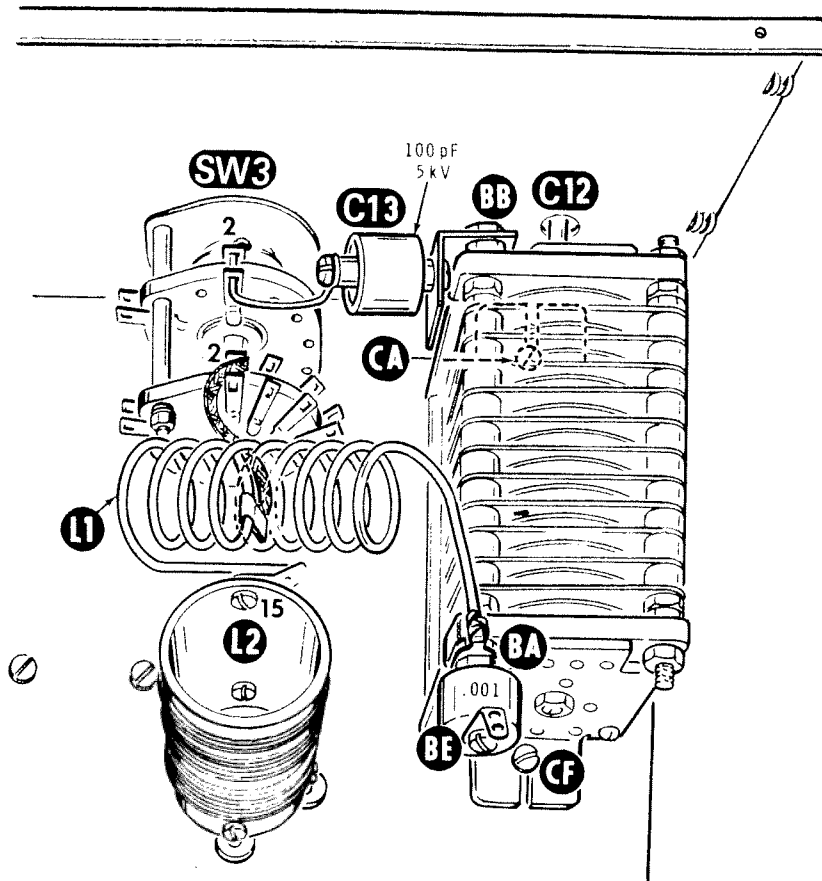

PICTORIAL 13

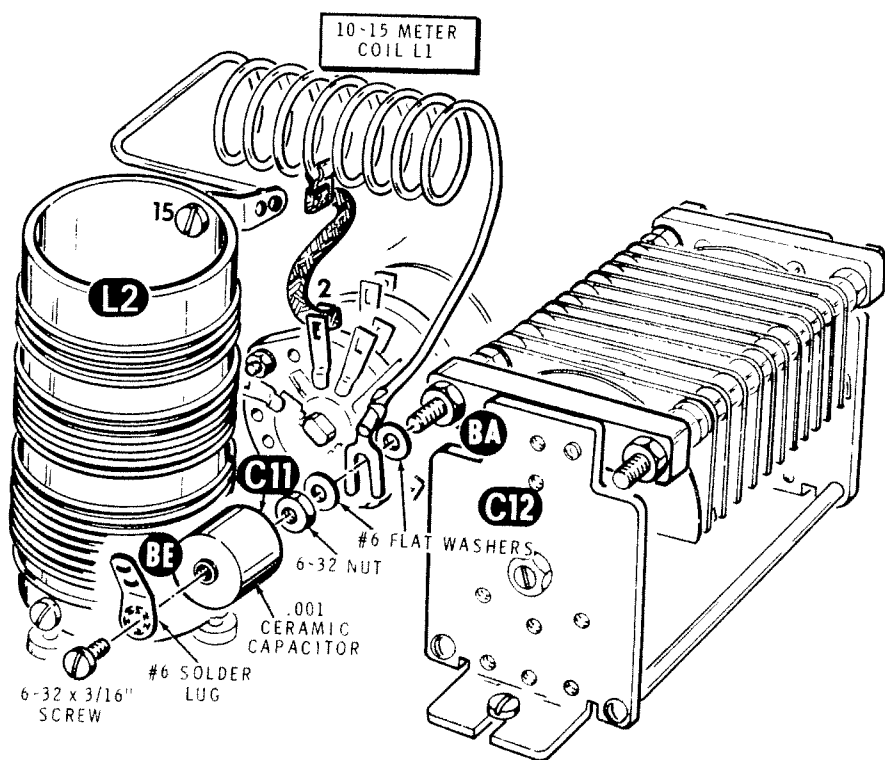

Detail 13F

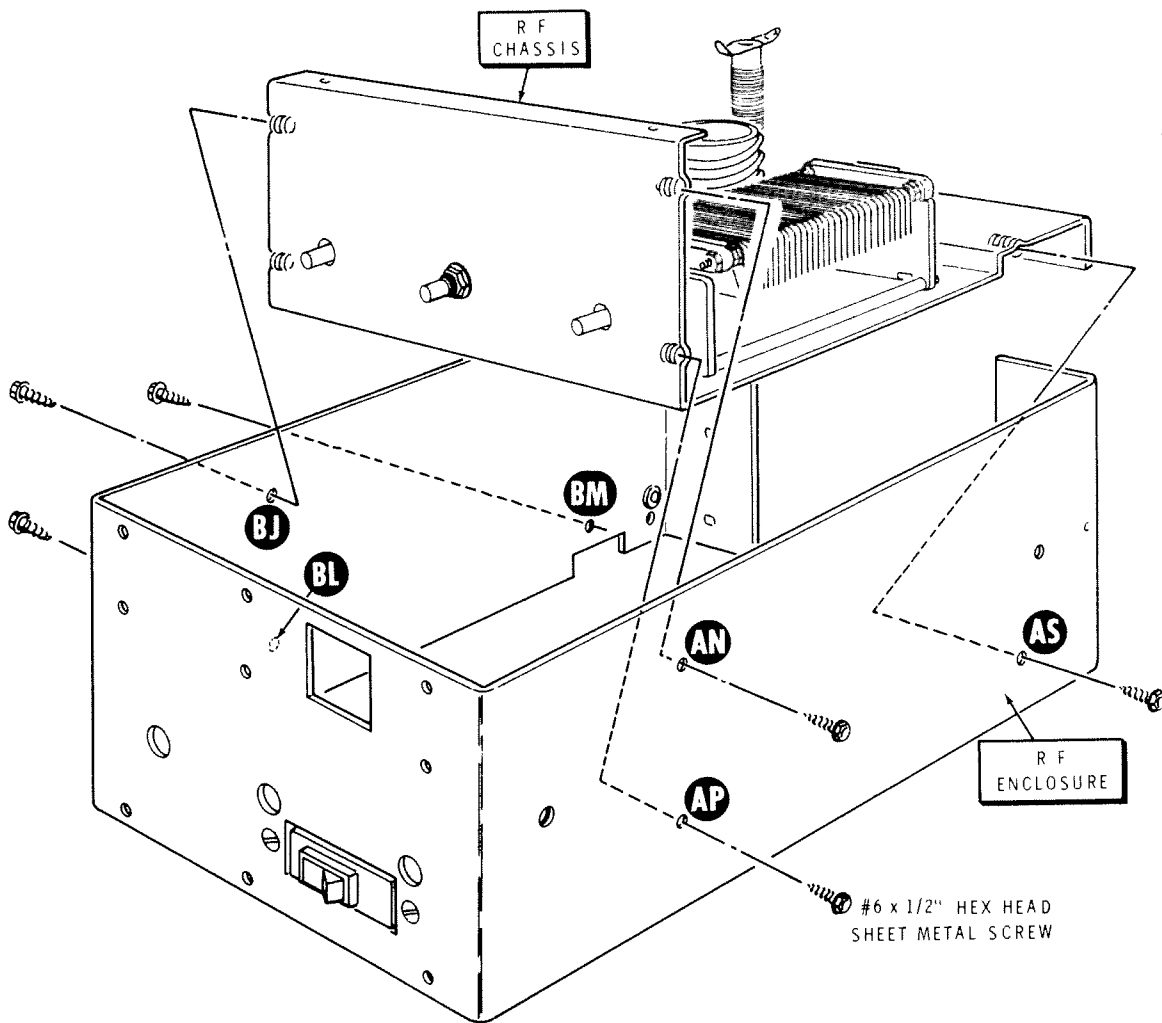

Detail 15D

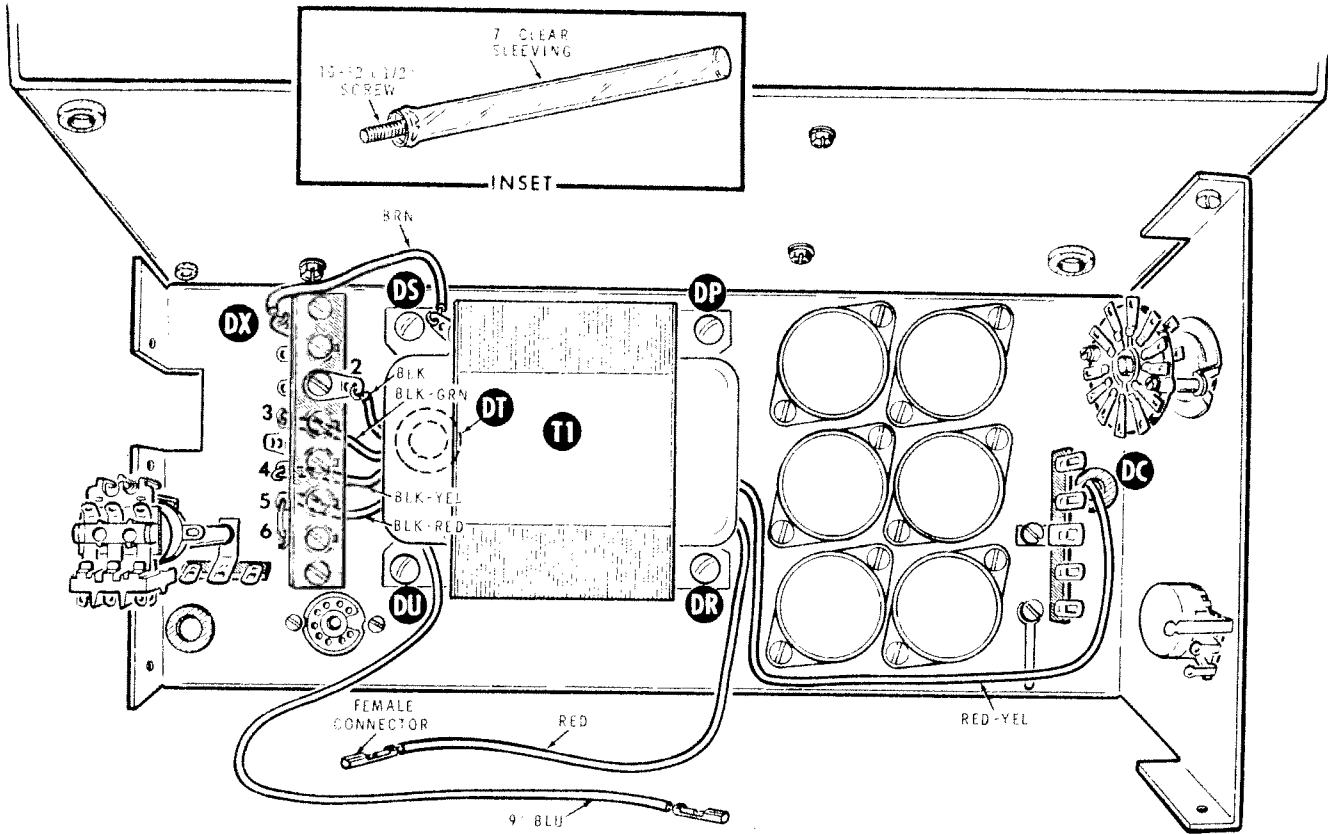

PICTORIAL 24

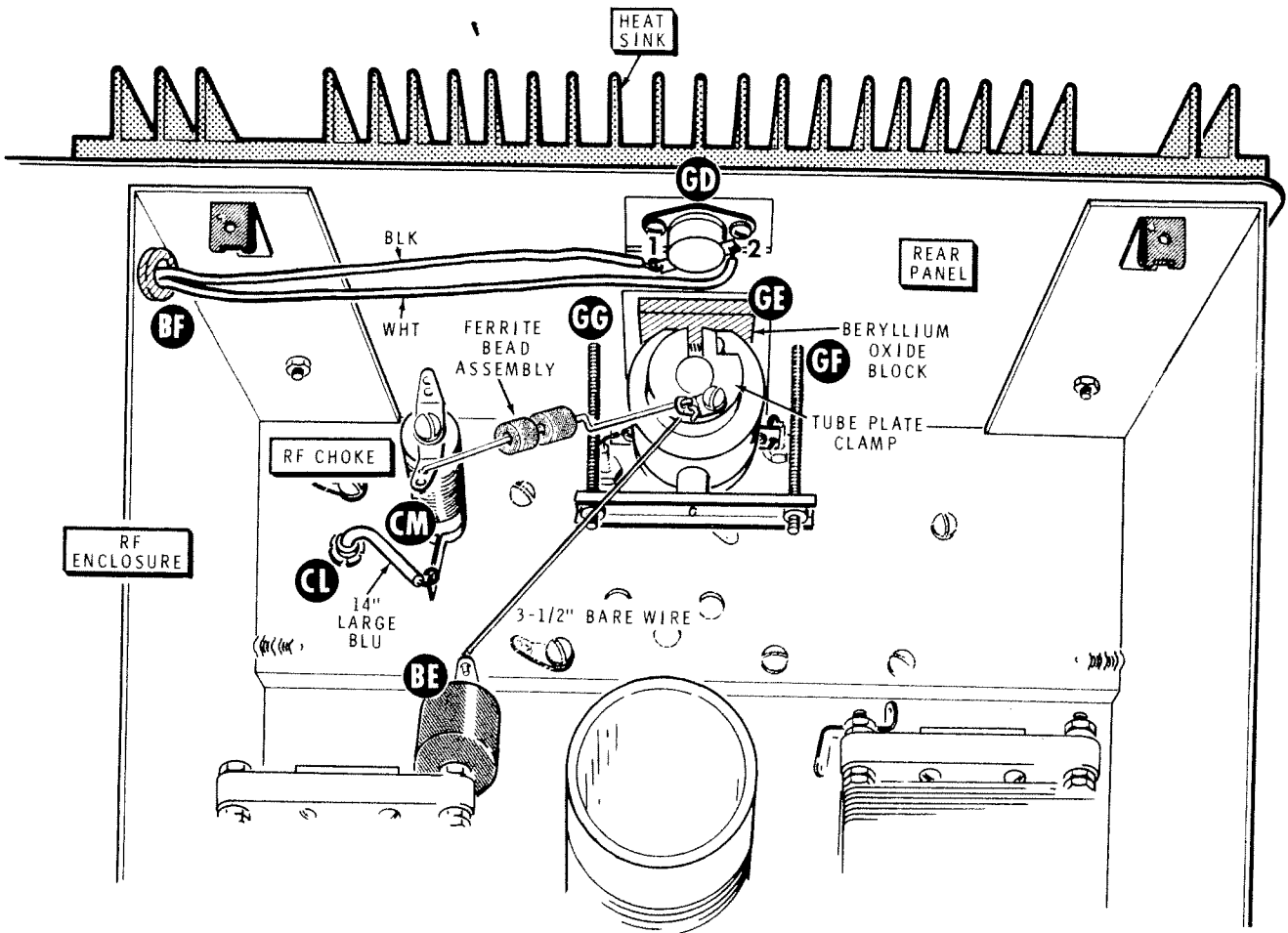

PICTORIAL 29

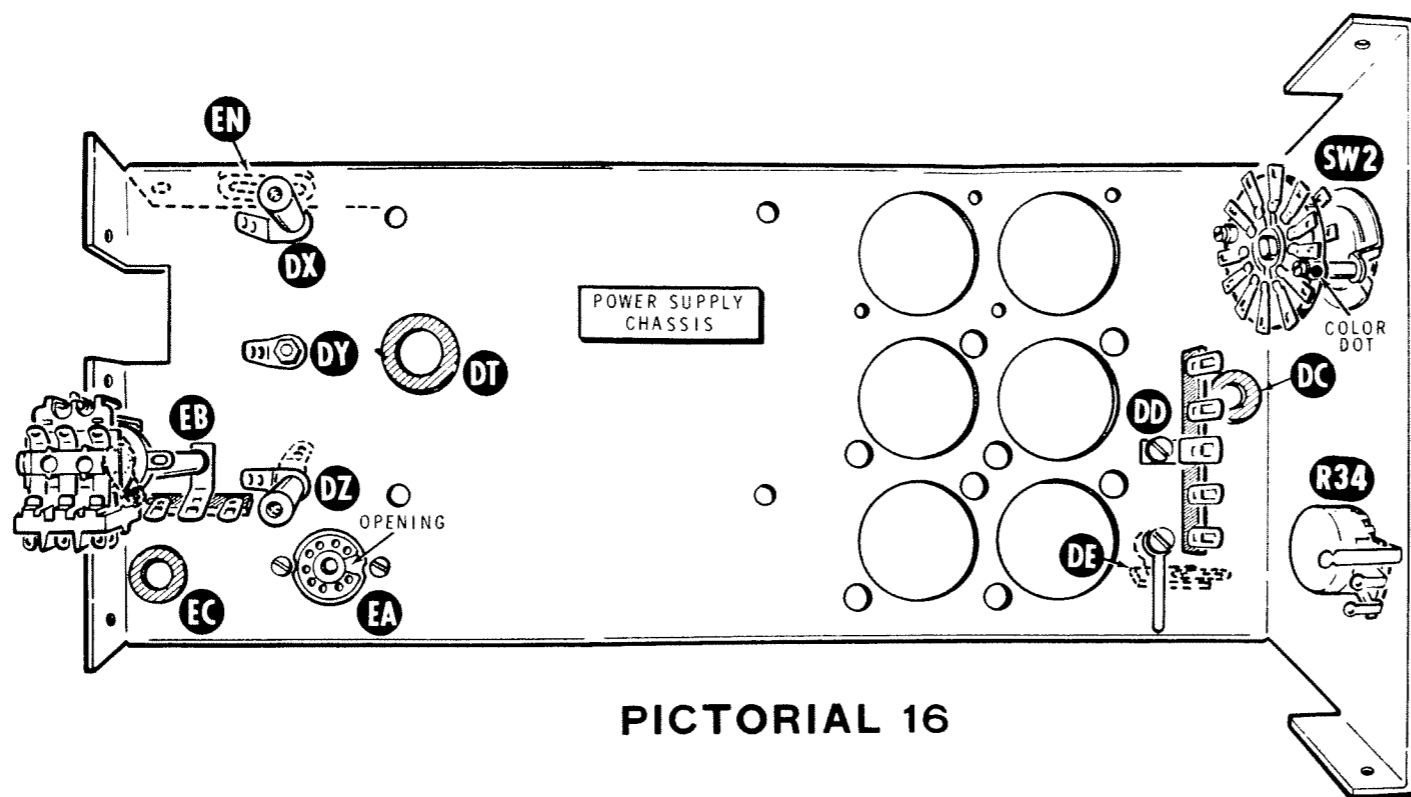

PICTORIAL 16

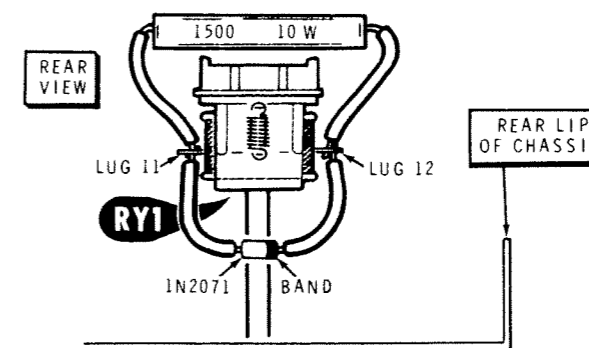

PICTORIAL 20B

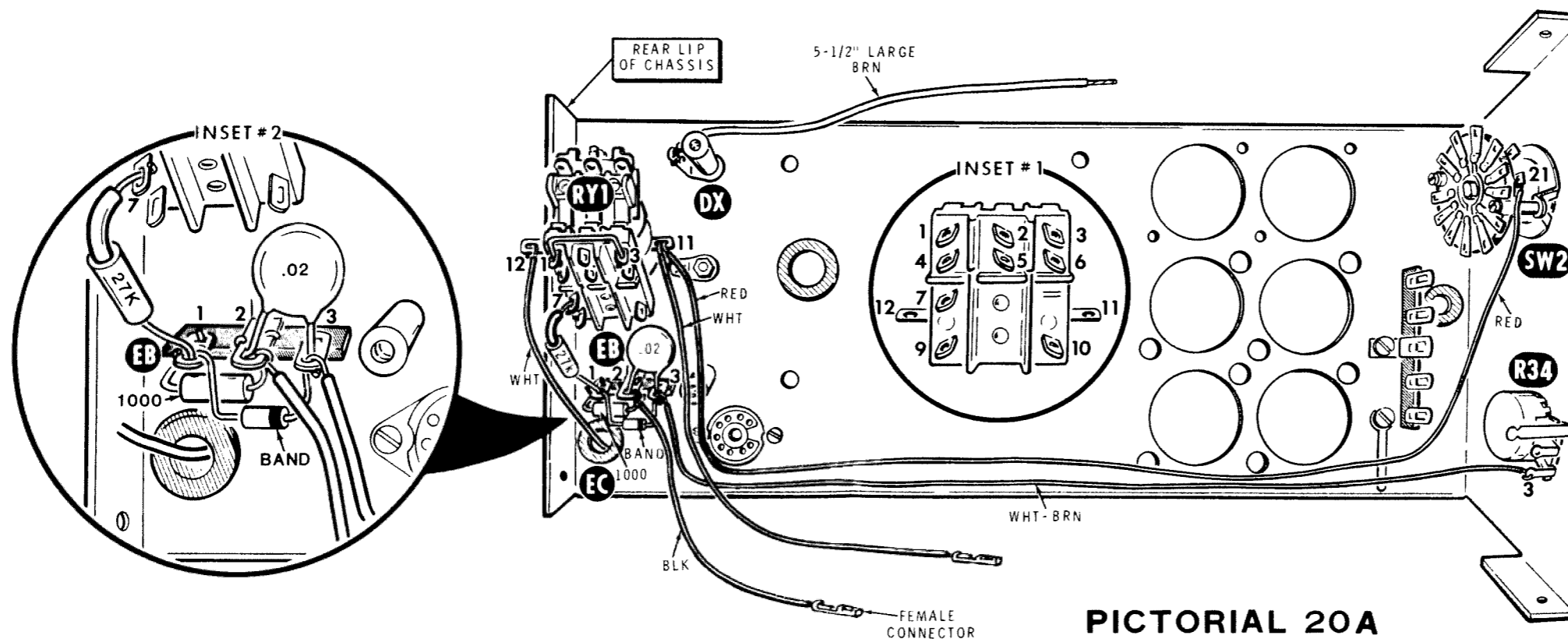

PICTORIAL 20A

POSITION T
PORTION OF
INTO THE C

Refer to Pic

Refer
in hole

THIS LUG
POINTS STRA
UP

SW2:
switch
positic
shown
this or
washer

100 kΩ
CONTRC
#10-12

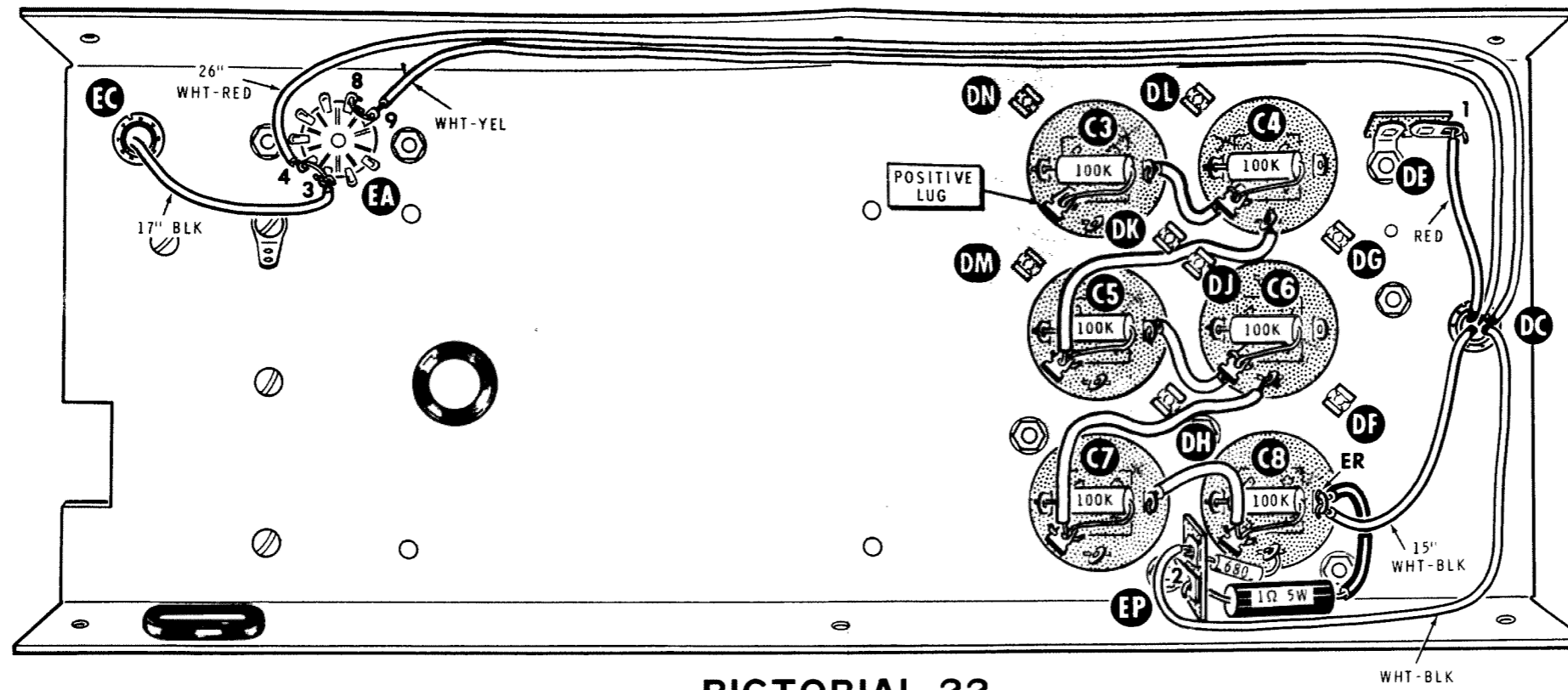

PICTORIAL 22

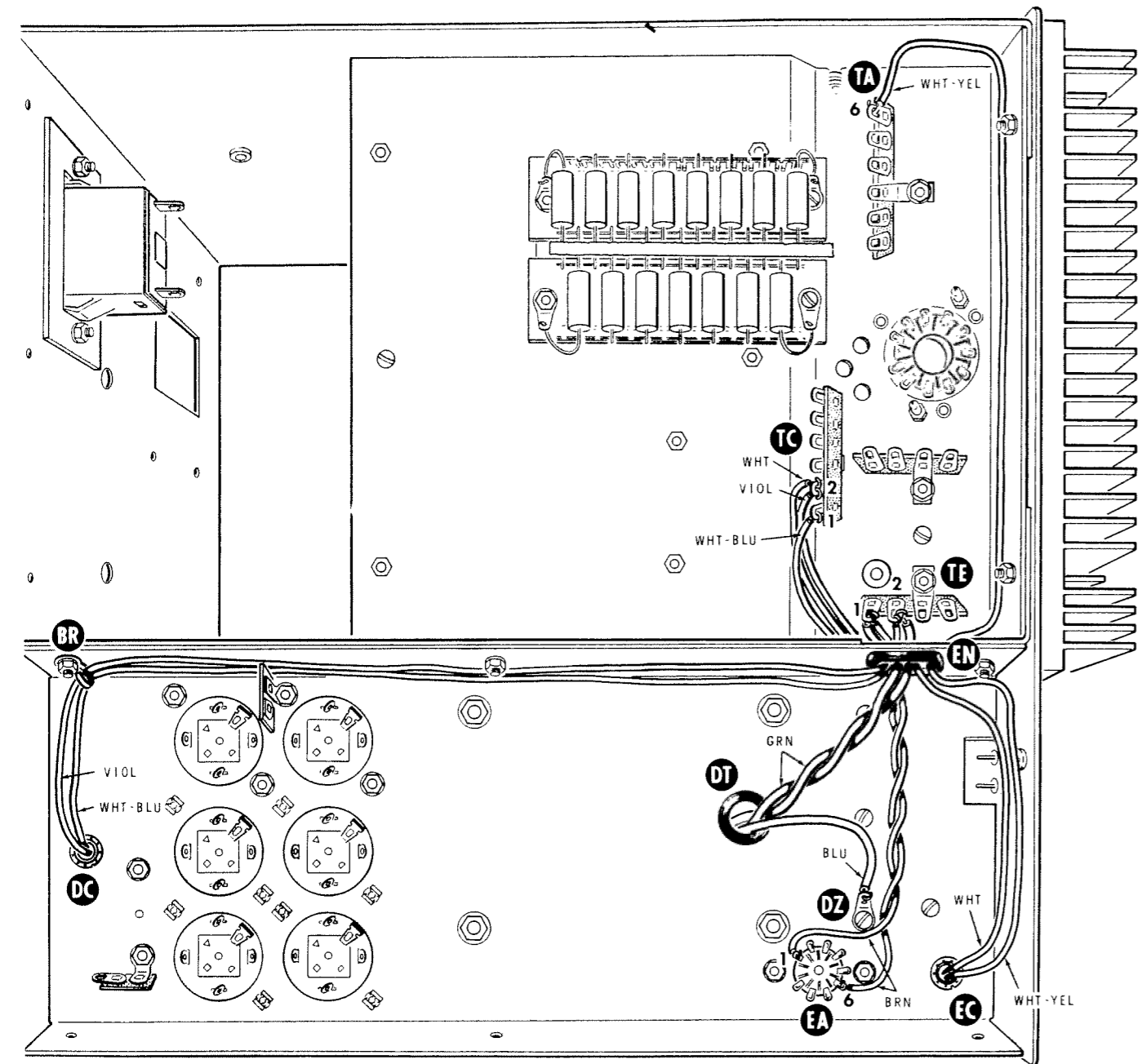

PICTORIAL 31

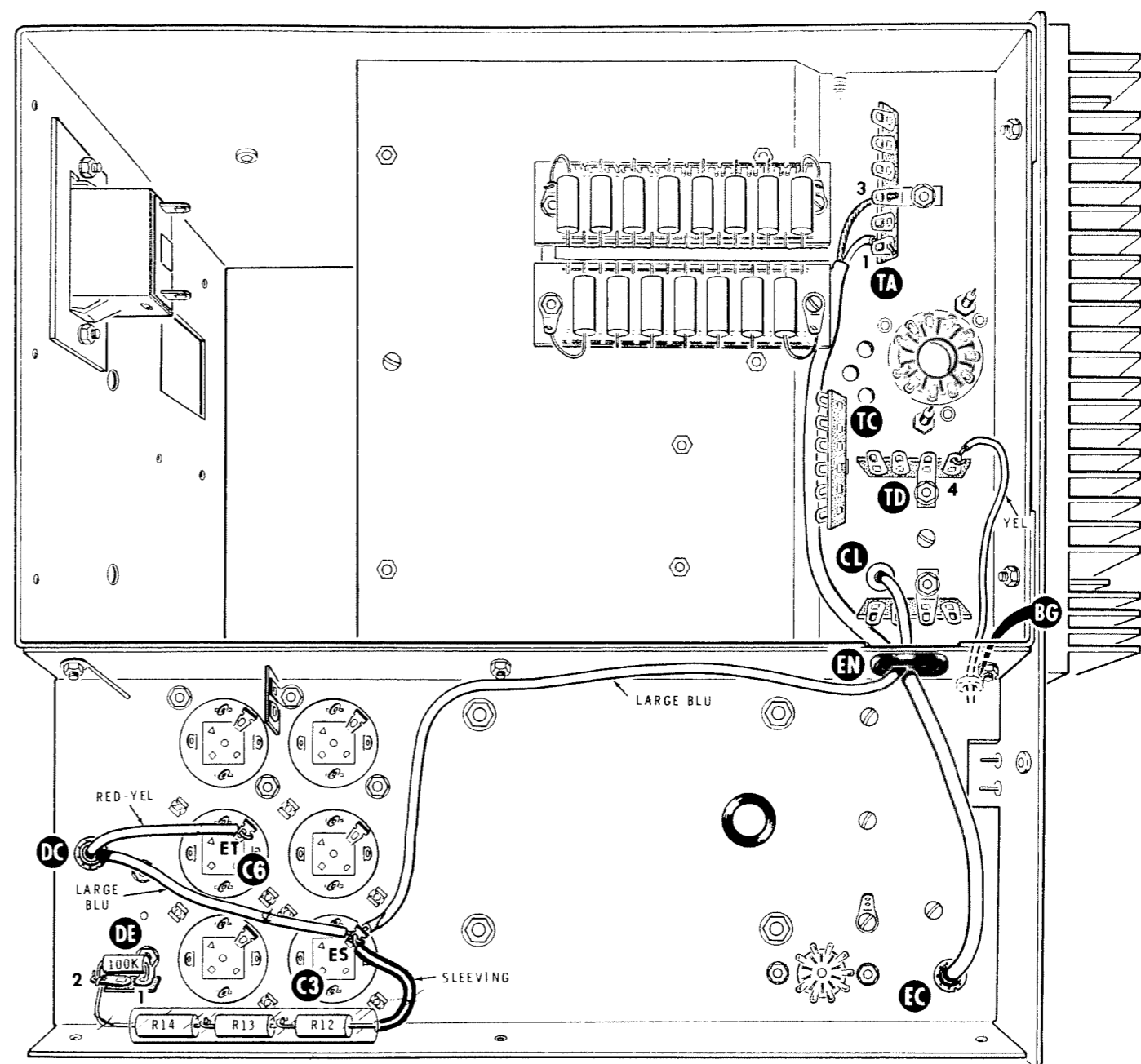

PICTORIAL 32

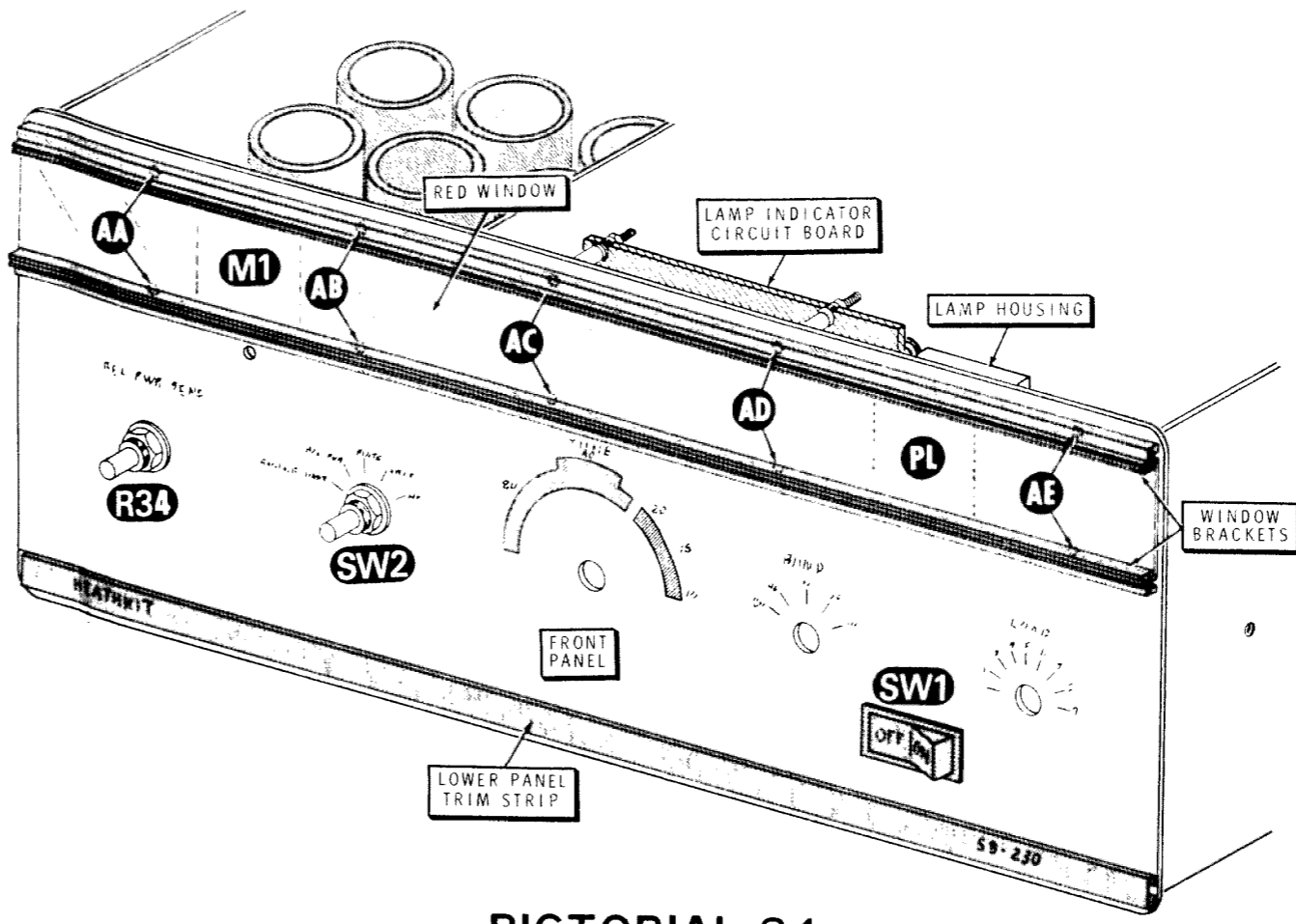

PICTORIAL 34

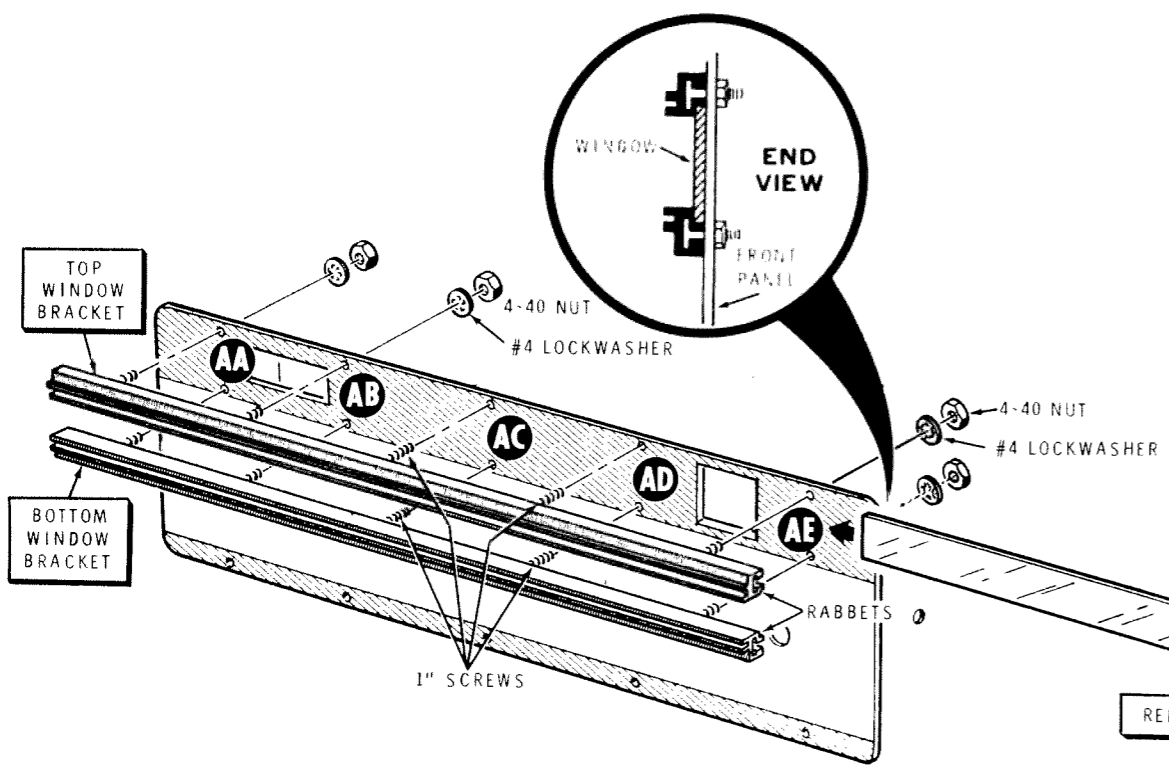

Detail 34B

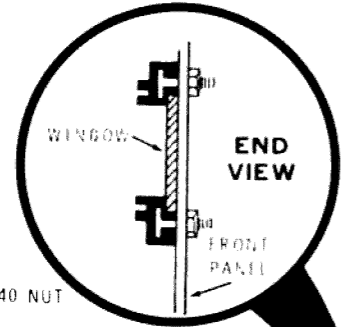
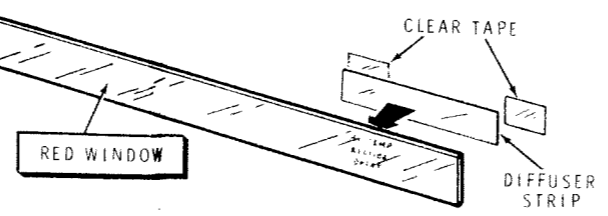

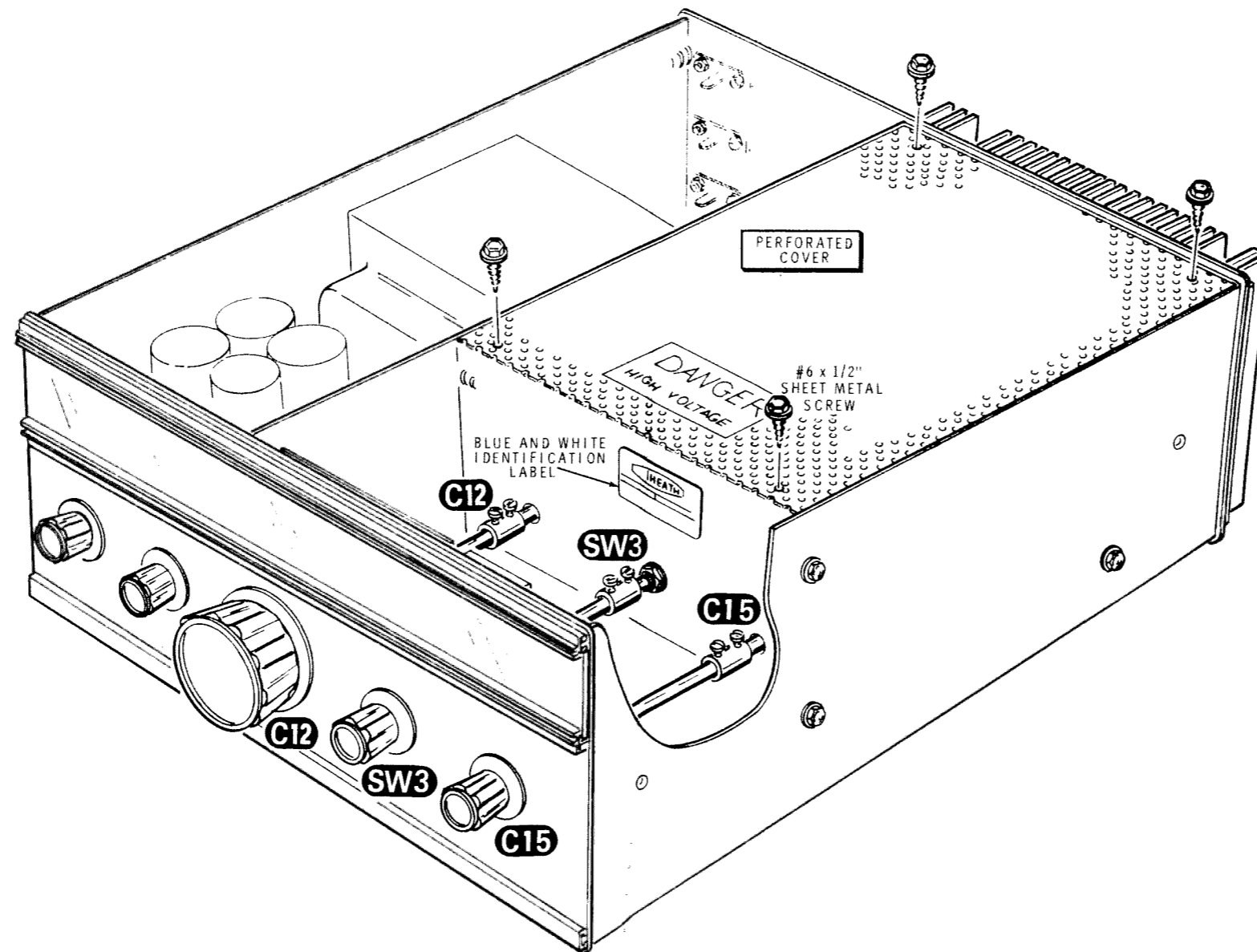

PICTORIAL 37

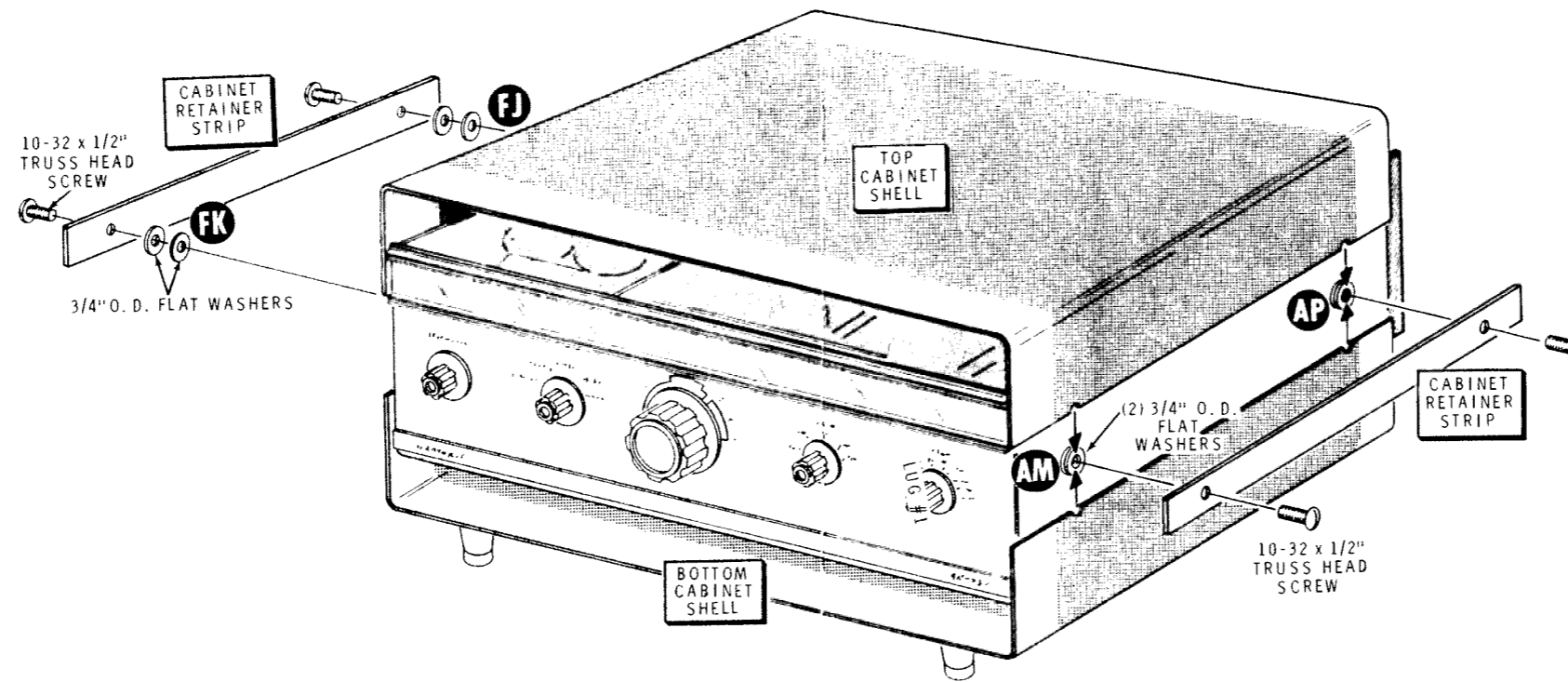

PICTORIAL 39

side 89 blant disse sider

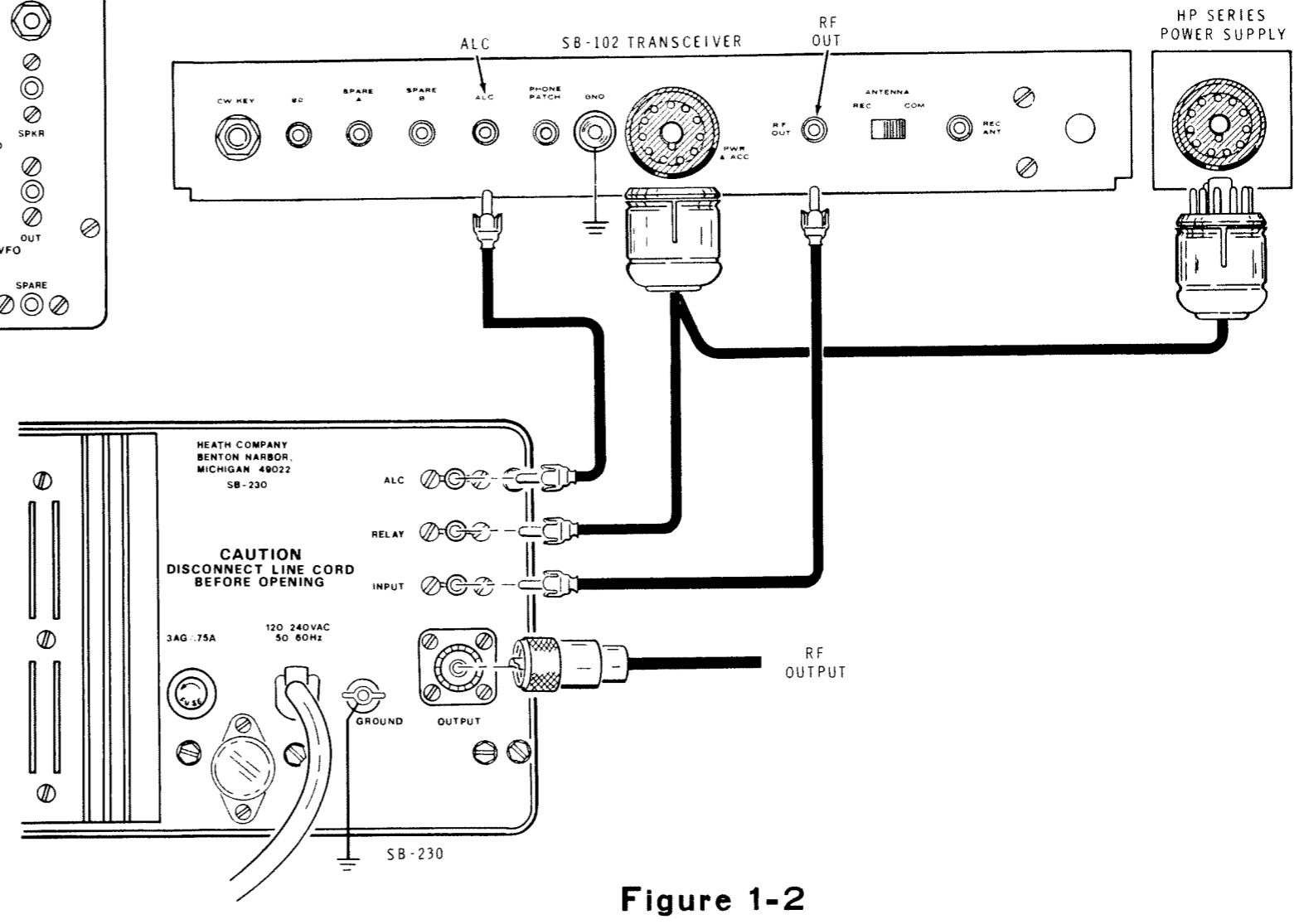
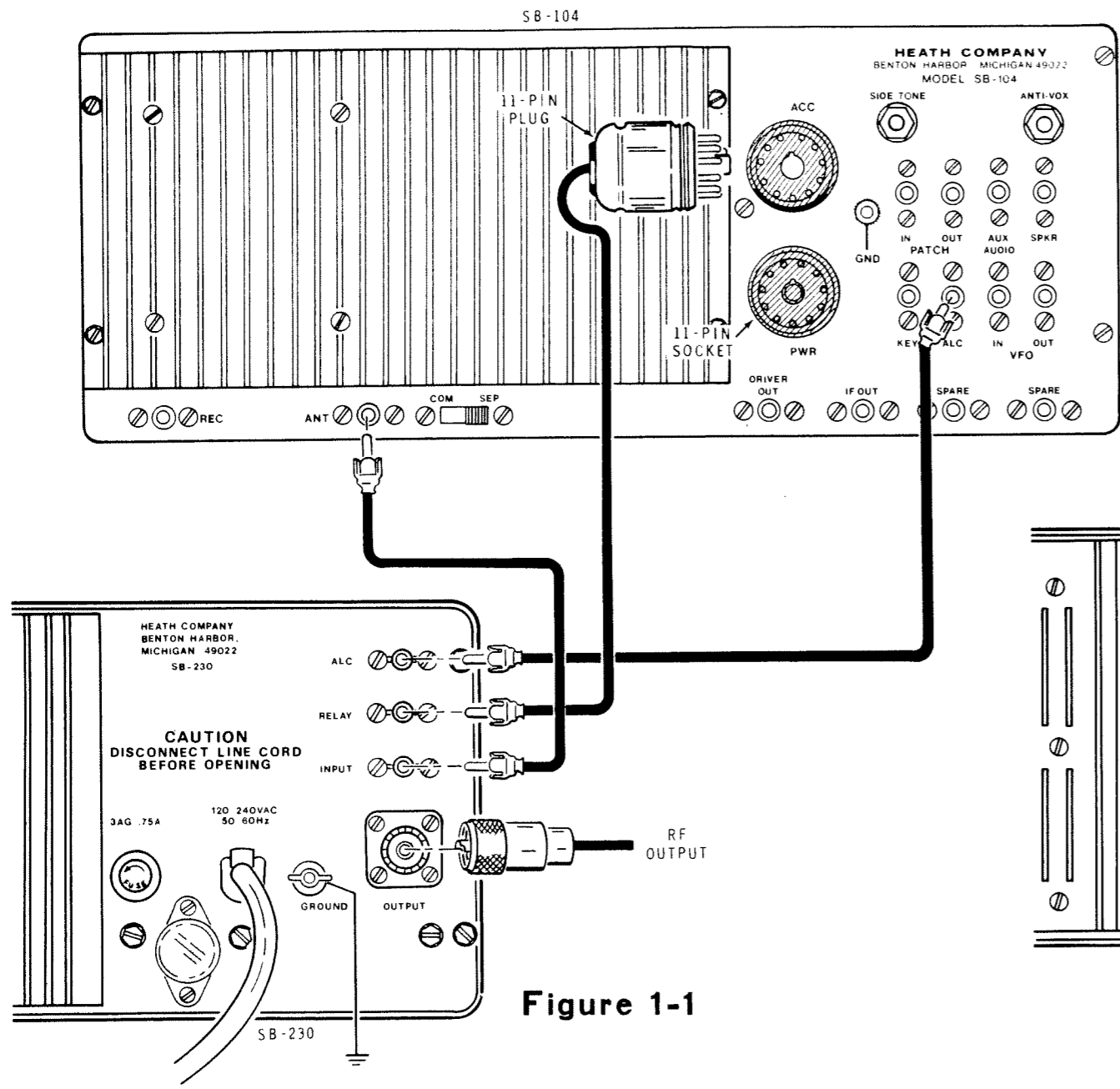

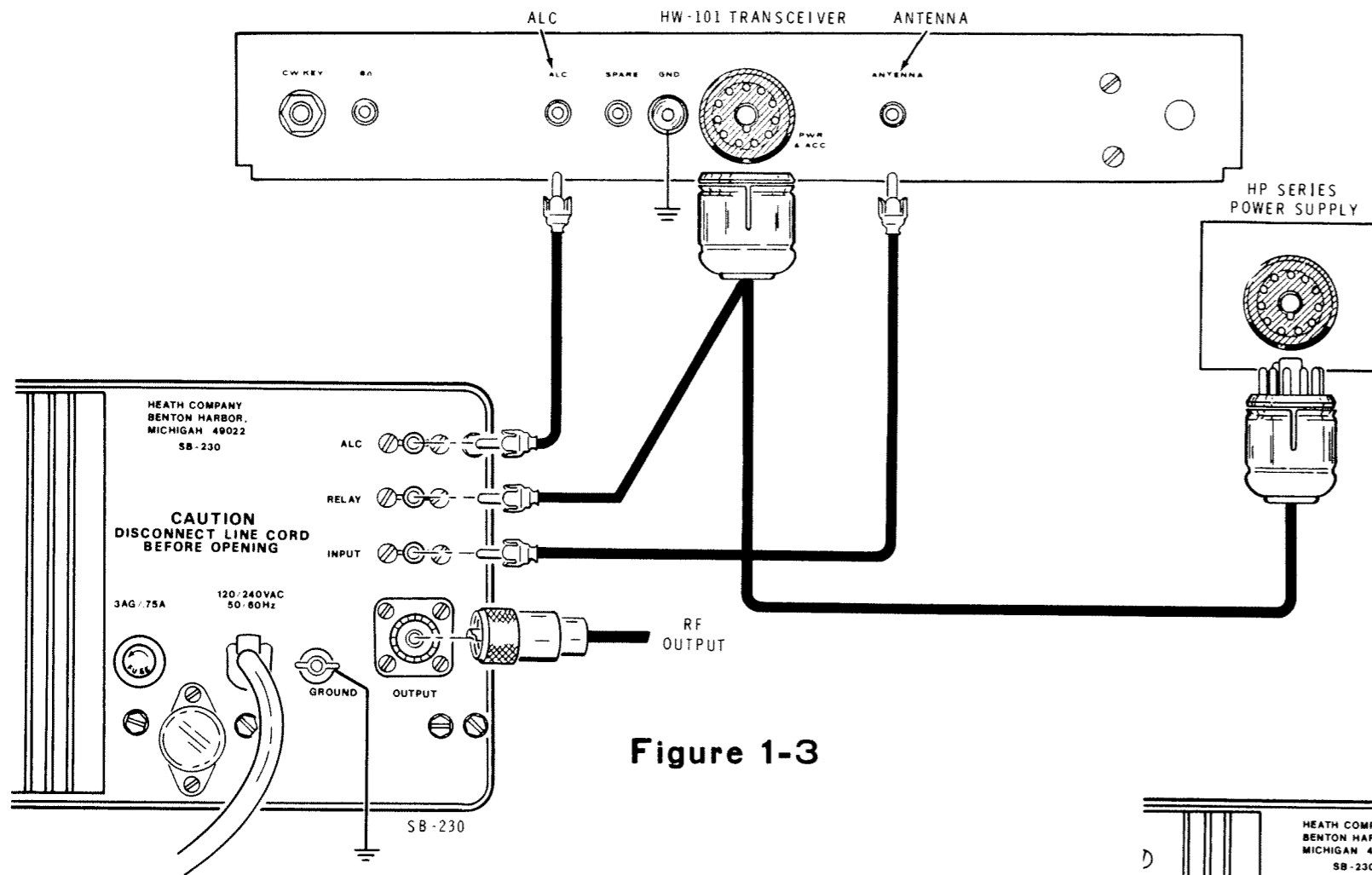

Figure 1-3

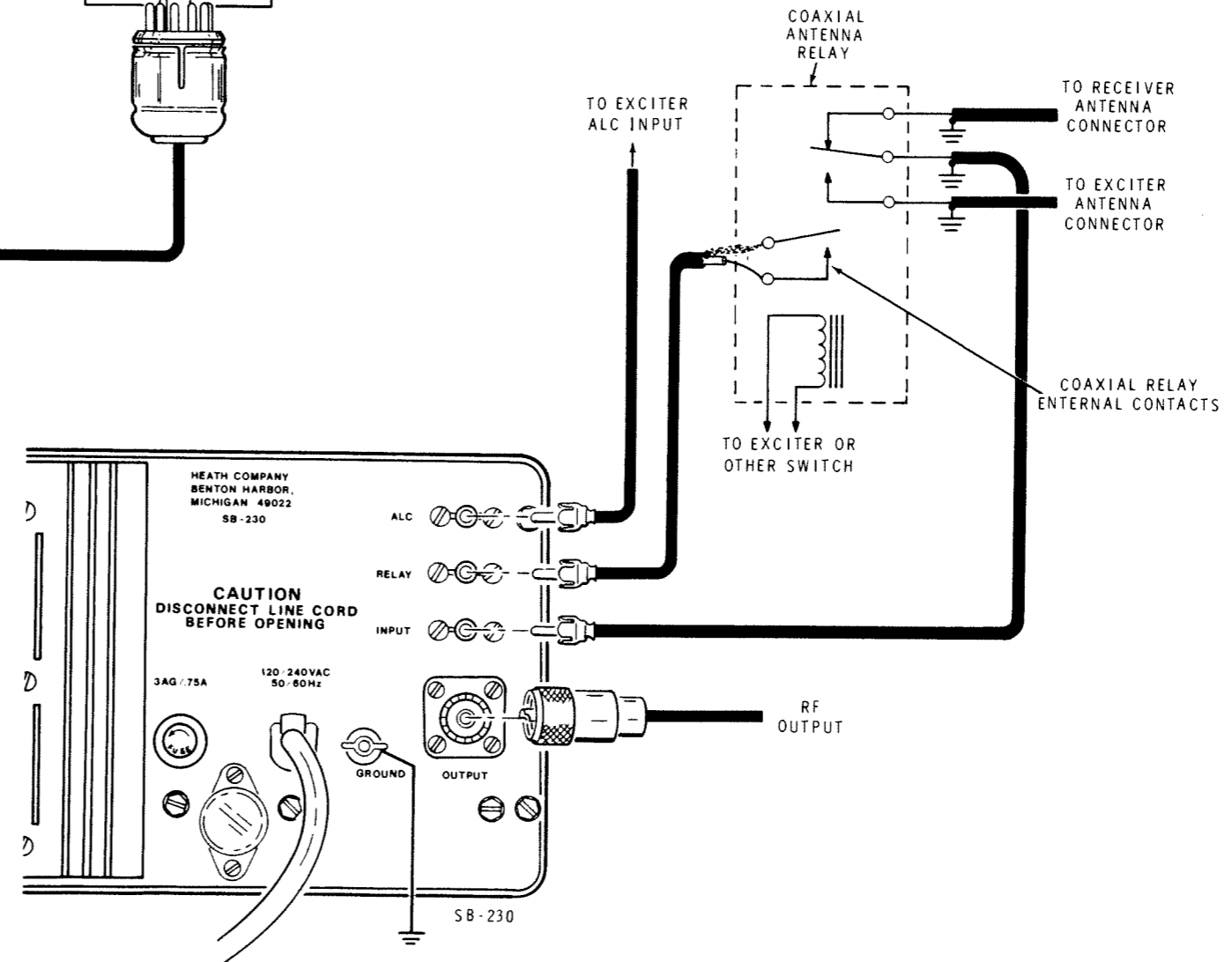

Figure 1-6

HEATH TI
POWER PI

The followi
Transceiver.

If you will
which has an
modify the
was not pre
the amplifier
action. The
should be pr

Refer to Fi
cable socke
install a ph
ordinary tw
Figure 2. T
cover and sl
the lamp o
connect the
and replace

IMPORTANT
tip of the p
wires to lug
relay will t
hold the An

ALC

If it is over
voltage whi
panel to rec
and a two-
socket to a
Connect ph

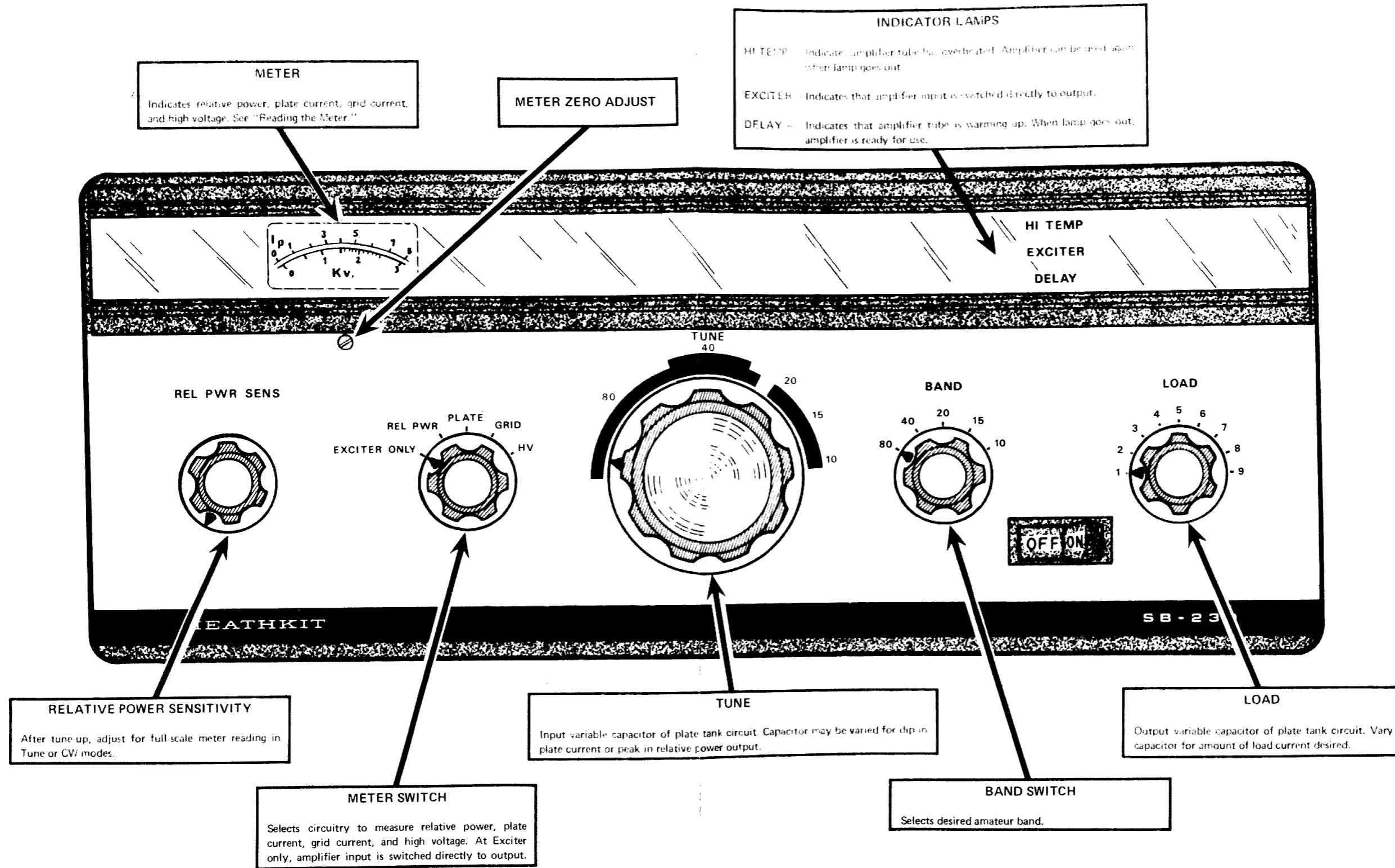

Figure 3

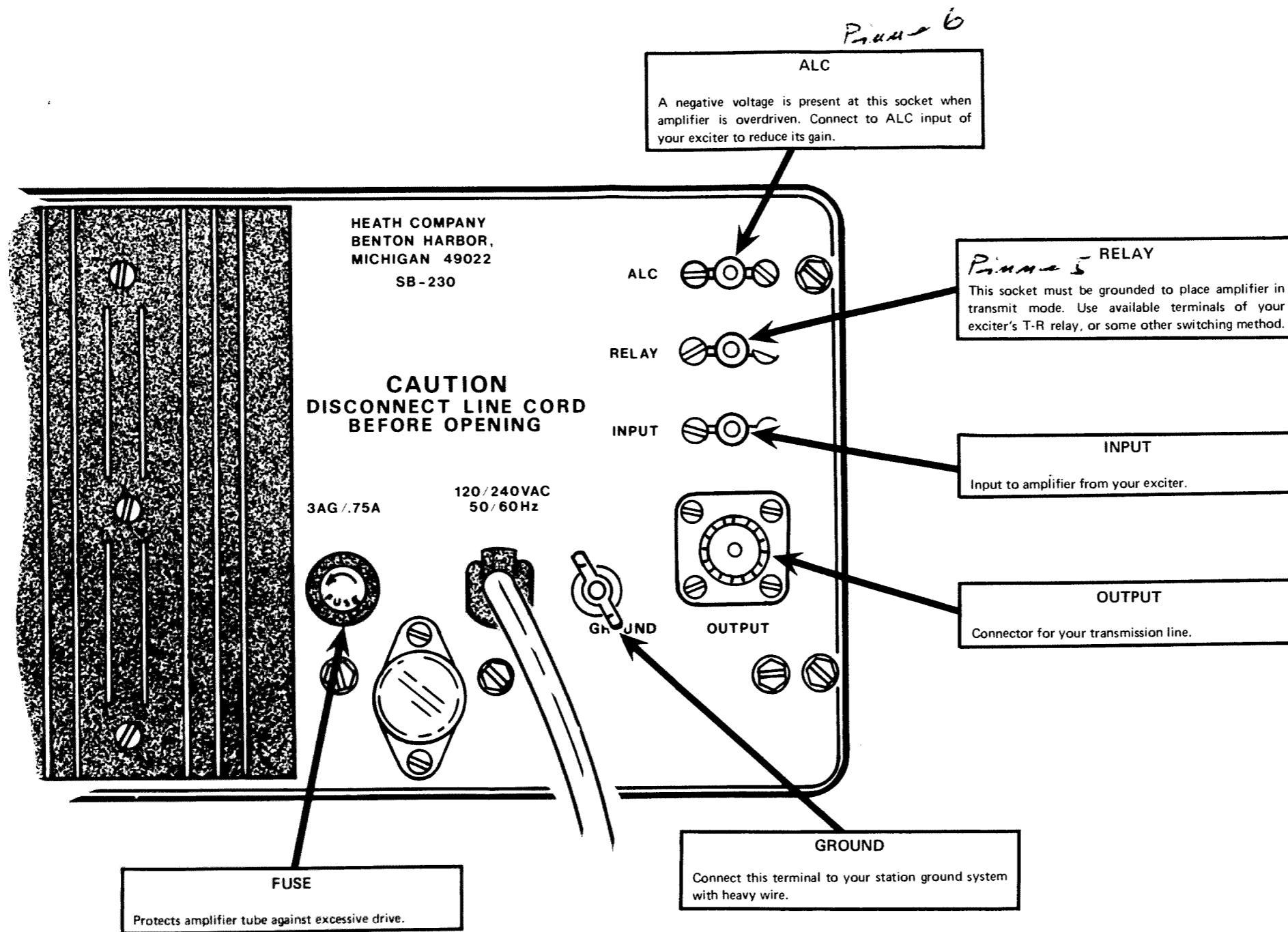
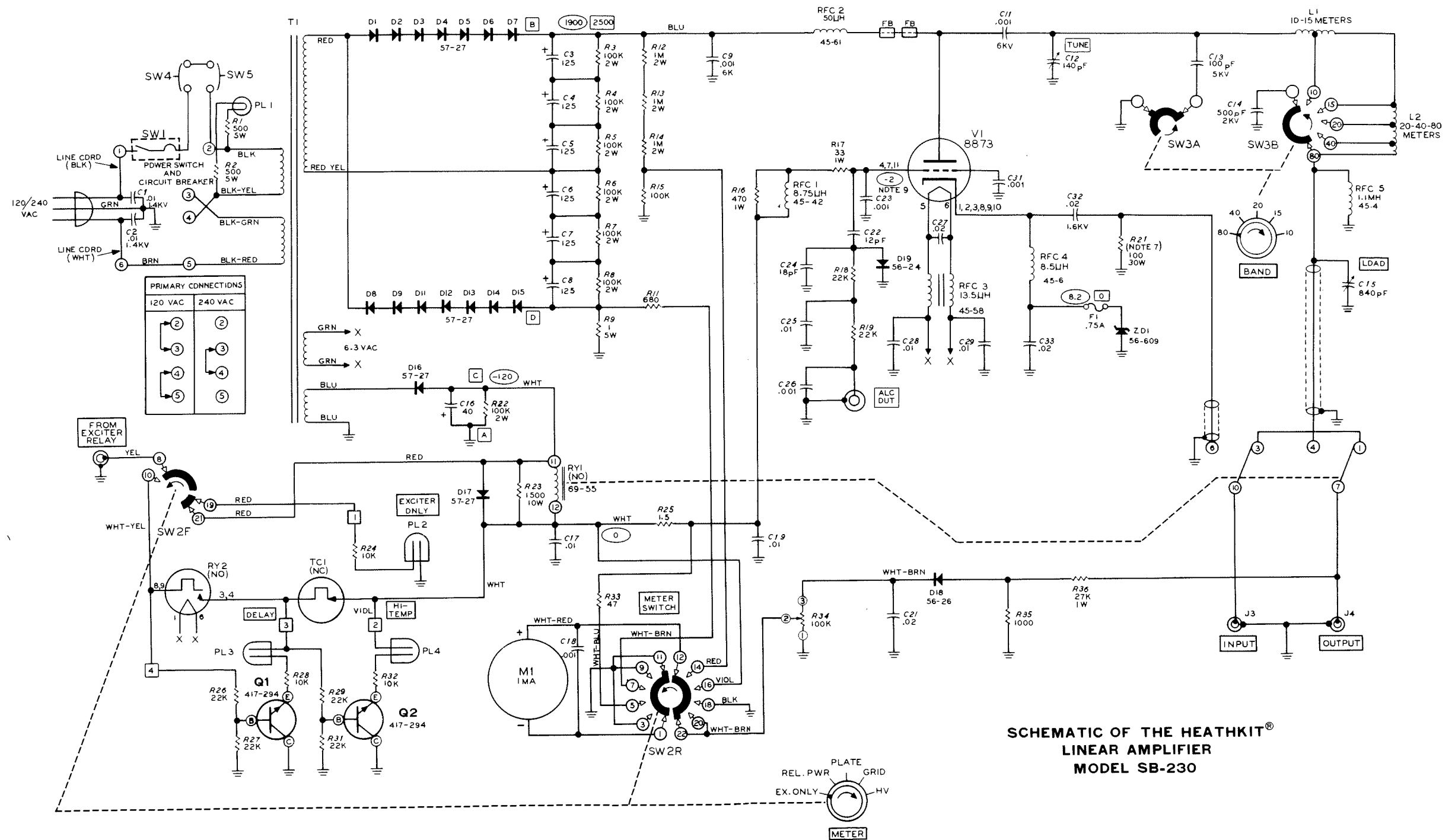

Figure 4



**SCHEMATIC OF THE HEATHKIT®
LINEAR AMPLIFIER
MODEL SB-230**

DIODE AND TRANSISTOR IDENTIFICATION CHART

COMPONENT	HEATH PART NO.	MAY BE REPLACED WITH	IDENTIFICATION
D1 THROUGH D17 D18 D19 ZD1	57-27 56-26 56-24 56-609	1N2071 1N191 1N458 1N280GA (8.2V, 1.5A)	NOTE: DIODES MAY BE SUPPLIED IN ANY OF THE FOLLOWING FIVE SHAPES. HEATH PART NUMBERS ARE STAMPED ON MOST DIODES.
Q1, Q2	417-294	MPSA42	

NOTES:

- ALL RESISTOR VALUES ARE IN OHMS (K=1,000; M=1,000,000).
- ALL CAPACITOR VALUES ARE IN MICROFARADS UNLESS OTHERWISE MARKED (pF=PICOFARADS).
- RELAY CONTACTS ARE IN THE INACTIVATED POSITION (RECEIVE OR EXCITER ONLY).
- SWITCH CONTACTS ARE SHOWN REAR VIEW. THE SWITCH POSITION IS SHOWN IN THE KNOB VIEW. AN ARROW SHOWS SWITCH MOVEMENT WITH CLOCKWISE ROTATION OF THE KNOB.
- REFER TO THE CHASSIS PHOTOGRAPHS AND X-RAY VIEWS FOR THE ACTUAL LOCATION OF PARTS.

- K = 1,000 pF = PICOFARADS
KV = KILOVOLTS PL = PILOT LAMP
M = 1,000,000 T.S. = THERMAL SWITCH
MH = MILLIHENRIES μH = MICROHENRIES
- R21 IS COMPOSED OF FIFTEEN 1500Ω, 2-WATT RESISTORS CONNECTED IN PARALLEL TO FORM A 100Ω, 30 WATT RESISTANCE.
- = DC VOLTS AT 500mA PLATE CURRENT.
 = DC VOLTS AT 25mA PLATE CURRENT.
 = CIRCUIT BOARD HOLE OR PIN.
 = FERRITE BEAD
- GRID VOLTS = -110V WITH METER SWITCH AT "EXCITER ONLY".

CUSTOMER SERVICE

REPLACEMENT PARTS

If you need a replacement part, please fill in the Parts Order Form that is furnished and mail it to the Heath Company. Or, if you write a letter, include the:

- Part number and description as shown in the Parts List.
- Model number and Series number from the blue and white label.
- Date of purchase.
- Nature of the defect.

Please do not return parts to the factory unless they are requested. Parts that are damaged through carelessness or misuse by the kit builder will not be replaced without cost, and will not be considered in warranty.

Parts are also available at the Heathkit Electronic Centers listed in your catalog. Be sure to provide the Heath part number. Bring in the original part when you request a warranty replacement from a Heathkit Electronic Center.

NOTE: Replacement parts are maintained specifically to repair Heathkit products. Parts sales for other reasons will be declined.

TECHNICAL CONSULTATION

Need help with your Heathkit? Self-Service? Construction? Operation? Call or write for assistance. You'll find our Technical Consultants eager to help with just about any technical problem except "customizing" for unique applications.

The effectiveness of our consultation service depends on the information you furnish. Be sure to tell us:

- The Model number and Series number from the blue and white label.
- The date of purchase.
- An exact description of the difficulty.
- Everything you have done in attempting to correct the problem.

Also include switch positions, connections to other units, operating procedures, voltage readings, and any other information you think might be helpful.

Please do not send parts for testing, unless this is specifically requested by our Consultants.

Hints: Telephone traffic is lightest at midweek. . . please be sure your Manual and notes are on hand when you call.

Heathkit Electronic Center facilities are also available for telephone or "walk-in" personal assistance.

REPAIR SERVICE

Service facilities are available, if they are needed, to repair your completed kit. (Kits that have been modified, soldered with paste flux or acid core solder, cannot be accepted for repair.)

If it is convenient, personally deliver your kit to a Heathkit Electronic Center. For warranty parts replacement, supply a copy of the invoice or sales slip.

If you prefer to ship your kit to the factory, attach a letter containing the following information directly to the unit:

- Your name and address.
- Date of purchase.
- Copies of all correspondence relevant to the service of the kit.
- A brief description of the difficulty.
- Authorization to return your kit C.O.D. for the service and shipping charges. (This will reduce the possibility of delay.)

Check the equipment to see that all screws and parts are secured. (Do not include any wooden cabinets or color television picture tubes, as these are easily damaged in shipment.) Place the equipment in a strong carton with at least **THREE INCHES** of *resilient* packing material (shredded paper, excelsior, etc.) on all sides. Use additional packing material where there are protrusions (control sticks, large knobs, etc.). If the unit weighs over 15 lbs., place this carton in another one with 3/4" of packing material between the two.

Seal the carton with reinforced gummed tape, tie it with a strong cord, and mark it "Fragile" on at least two sides. Remember, the carrier will not accept liability for shipping damage if the unit is insufficiently packed. Ship by prepaid express, United Parcel Service, or insured Parcel Post to:

Heath Company
Service Department
Benton Harbor, Michigan 49022

HEATH

Schlumberger

HEATH COMPANY • BENTON HARBOR, MICHIGAN
THE WORLD'S FINEST ELECTRONIC EQUIPMENT IN KIT FORM